



fontealta



CHI SIAMO

La storia di Fontealta inizia nel 1999 a Viareggio, sul litorale toscano, fatto di stabilimenti balneari ed industrie navali. Competenze e radici profonde nella conoscenza della rubinetteria ci fecero iniziare con la progettazione e la produzione delle prime colonne doccia per portare l'acqua in riva al mare e sui ponti di yacht e navi.

Da allora abbiamo scelto di diventare specialisti di produzione in acciaio inox 316. Oggi lo facciamo su nostro disegno esclusivo per tutti i prodotti Fontealta: rubinetti, miscelatori, docce, lavapièdi ed accessori da esterno. Materie prime, fornitori e lavorazioni appartengono ad un ciclo produttivo 100% italiano.

Abbiamo piena disponibilità alla modifica dei prodotti standard o a produzioni su misura, con l'opportunità di realizzare progetti tecnici per i nostri clienti, che soddisfino esigenze personalizzate.

La nostra garanzia è chiara su tutti i prodotti, per ordini e trasporto in ogni località del mondo, attraverso una rete di rivenditori che sono tra i migliori specialisti dei settori idrosanitario, outdoor, giardino e piscina.

Oggi siamo sempre più impegnati nel concetto di "sostenibilità", a partire dal materiale - l'acciaio è il materiale più riciclato al mondo, praticamente riciclabile all'infinito - e verso tutti gli aspetti legati al prodotto: materiali d'imballaggio, accessori a corredo dei prodotti ed iniziative legate al marketing ed alla comunicazione del brand.

WHO WE ARE

Fontealta's story begins in 1999 in Viareggio, a renowned spot on the Tuscan coast thanks to its shipyards and beach resorts. Having our skills rooted in the manufacturing of tapware, we decided to employ them to design and produce the first shower columns to bring water to the seashore and to the yacht decks.

Since then, we have chosen to become specialists in the production of articles in stainless steel Aisi 316.

Today we keep developing this concept, implementing our own exclusive design for all Fontealta products: faucets, mixers, showers, foot washers and outdoor accessories. Raw materials, suppliers and processing belong to a 100% Italian production cycle.

We have full availability to study modifications on our standard products or custom-made solutions, creating technical designs for our customers, meeting their specific needs.

Our guarantee is clear on all products, for orders and deliveries to any location in the world, through a network of dealers who are among the best specialists in the sanitaryware, outdoor, garden and pool sectors.

Today we are increasingly committed to the concept of "sustainability," not only with the choice of the material - steel is the most recycled material in the world, essentially infinitely recyclable - but also with all aspects related to the product: packaging materials, accessories and marketing and brand communication activities.

QUI SOMMES-NOUS

L'histoire de Fontealta commence en 1999 à Viareggio, un site renommé de la côte toscane grâce à ses chantiers navals et ses stations balnéaires. Notre expérience et notre connaissance approfondies de la robinetterie nous ont conduits à la conception et production des premières colonnes de douche pour amener l'eau au bord de la mer et sur les ponts des yachts et des bateaux. Depuis lors, nous avons choisi de devenir des spécialistes de la production d'articles en acier inoxydable Aisi 316. Aujourd'hui, nous continuons à développer ce concept, en mettant en œuvre notre propre design exclusif pour tous les produits Fontealta : robinets, mitigeurs, douches, rince-pieds et accessoires d'extérieur. Les matières premières, les fournisseurs et le traitement font partie d'un cycle de production 100% italien.

Nous avons toute la disponibilité nécessaire pour étudier des modifications sur nos produits standard ou des solutions sur mesure, en créant des designs techniques pour nos clients, répondant à leurs besoins spécifiques.

Notre garantie est claire sur tous les produits, pour les commandes et les livraisons dans n'importe quel endroit du monde, à travers un réseau de revendeurs qui comptent parmi les meilleurs spécialistes dans les secteurs du sanitaire, de l'outdoor, du jardin et de la piscine.

Aujourd'hui, nous sommes de plus en plus engagés dans le concept de "durabilité", non seulement dans le choix du matériau - l'acier est le matériau le plus recyclé au monde, essentiellement recyclable à l'infini - mais aussi dans tous les aspects liés au produit: matériaux d'emballage, accessoires et activités de marketing et de communication de la marque.

QUIÉNES SOMOS

La historia de Fontealta empieza en 1999 en Viareggio, un lugar de renombre en la costa toscana gracias a sus astilleros y complejos turísticos de playa. Las profundas raíces de nuestra experiencia con la grifería nos hicieron empezar con el diseño y la producción de las primeras columnas de ducha para llevar el agua a la orilla del mar y a las cubiertas de yates y barcos. Desde entonces, hemos optado por convertirnos en especialistas en la producción de artículos de acero inoxidable Aisi 316.

Hoy seguimos desarrollando este concepto, implementando nuestro propio diseño exclusivo para todos los productos Fontealta: grifos, mezcladores, duchas, lavapiés y accesorios de exterior. Las materias primas, los proveedores y la elaboración pertenecen a un ciclo de producción 100% italiano.

Tenemos plena disponibilidad para estudiar modificaciones sobre nuestros productos estándar o soluciones a medida, creando diseños técnicos para nuestros clientes, satisfaciendo sus necesidades específicas. Nuestra garantía es clara en todos los productos, para pedidos y entregas en cualquier lugar del mundo, a través de una red de distribuidores que se encuentran entre los mejores especialistas en los sectores de sanitarios, exteriores, jardín y piscina.

Hoy estamos cada vez más comprometidos con el concepto de "sostenibilidad", no sólo con la elección del material - el acero es el material más reciclado del mundo, esencialmente reciclable hasta el infinito, sino también con todos los aspectos relacionados con el producto: materiales de embalaje, accesorios y actividades de marketing y comunicación.

ÜBER UNS

Die Geschichte von Fontealta begann 1999 in Viareggio, einer für ihre Werften und Strandbäder bekannten Stadt an der toskanischen Küste. Da unsere Fähigkeiten in der Herstellung von Wasserhähnen verwurzelt waren, beschlossen wir, sie zu nutzen, um die ersten Duschsäulen zu entwerfen und zu produzieren, um Wasser ans Ufer und auf die Decks von Yachten zu bringen. Seitdem haben wir uns auf die Herstellung von Artikeln aus rostfreiem AISI 316 Stahl spezialisiert.

Heute entwickeln wir dieses Konzept weiter und setzen unser exklusives Design auf alle Fontealta-Produkte ein: Armaturen, Mischbatterien, Brausen, Fußspülungen und Accessoires für den Außenbereich.

Rohstoffe, Lieferanten und Verarbeitung gehören zu einem 100% italienischen Produktionszyklus.

Wir sind jederzeit in der Lage, Änderungen an unseren Standardprodukten vorzunehmen oder maßgeschneiderte Lösungen zu entwickeln, um unseren Kunden ein technisches Design zu bieten, das ihren spezifischen Anforderungen entspricht.

Unsere Garantie gilt für alle Produkte, Bestellungen und Lieferungen auf der ganzen Welt, über ein Netz von Händlern, die zu den besten Spezialisten in den Bereichen Sanitär, Outdoor, Garten und Pool gehören.

Heute engagieren wir uns zunehmend für das Konzept der „Nachhaltigkeit“, nicht nur bei der Wahl des Materials - Stahl ist das am häufigsten recycelte Material der Welt und im Grunde unendlich oft wiederverwertbar - sondern auch bei allen Aspekten des Produkts: Verpackungsmaterial, Zubehör und Marketing- und Markenkommunikationsaktivitäten.



SPECIALISTI DELL' ACCIAIO

La nostra azienda, nata con l'intenzione di realizzare rubinetteria in maniera esclusiva per i nostri clienti, fu da subito attratta dall'acciaio rispetto all'ottone. Capimmo le potenzialità di questo materiale e le unimmo alle nostre competenze tecniche. Furono scelti anche i macchinari in cui la mano dell'uomo facesse la differenza, sia per la lavorazione che per il controllo sul prodotto. La composizione dell'acciaio 316 gli conferisce resistenza a tutti i cloruri e, quindi, lo rende adatto sia agli ambienti marini che agli ambienti sanificati a cloro, come le piscine. In particolare, Fontealta impiega l'acciaio 316L, che mantiene tutte le caratteristiche dell'acciaio inossidabile anche quando dev'essere lavorato ad alte temperature, come ad esempio le lavorazioni di saldatura. La discriminante nella scelta del materiale, dunque, passa dall'uso che quello stesso materiale avrà. Siamo "Specialisti dell'acciaio", in grado di calzare perfettamente la soluzione di prodotto con l'esigenza di installazione del cliente. Un'importante considerazione finale è che il nostro prodotto perfetto per l'esterno, lo sarà ancora di più per un ambiente indoor, senza preclusioni.

STAINLESS STEEL SPECIALISTS

Our company, which was founded with the intention of making faucets for our customers, was soon attracted to steel over brass. We understood the potential of this material and combined it with our technical expertise. Machinery was also chosen in which the human hand makes the difference, both in terms of processing and product control. The composition of 316 steel gives it resistance to all chlorides and therefore makes it suitable for both marine and chlorine-sanitised environments, such as swimming pools. In particular, Fontealta uses 316L steel, which retains all the characteristics of stainless steel even when it has to be processed at high temperatures, as in the case of welding. We are 'Steel Specialists', able to perfectly match the product solution to the customer's installation requirements. An important final consideration is that our product that is perfect for outdoors, will be even more so for an indoor environment.

SPÉCIALISTES DE L'ACIER

Notre entreprise, qui a été fondée avec l'intention de fabriquer des robinets pour nos clients, a été bientôt attirée par l'acier plutôt que par le laiton. Nous avons compris le potentiel de ce matériau et l'avons associé à notre expertise technique. Nous avons également opté pour des machines dans lesquelles la main de l'homme fait la différence, tant au niveau de la transformation que du contrôle du produit. La composition de l'acier 316 lui confère une résistance à tous les chlorures et par conséquent le rend apte à être utilisé aussi bien dans des environnements marins que dans des environnements assainis par le chlore, comme les piscines. En particulier, Fontealta utilise l'acier 316L, qui conserve toutes les caractéristiques de l'acier inoxydable même lorsqu'il doit être traité à des températures élevées, comme dans le cas de la soudure. Nous sommes des "spécialistes de l'acier", capables d'adapter parfaitement la solution produit aux exigences de l'installation du client. Une dernière considération importante est que notre produit, qui est parfait pour l'extérieur, le sera encore plus pour un environnement intérieur, sans exclusion.

ESPECIALISTAS DEL ACERO

Nuestra empresa, que nació con la intención de fabricar grifería para nuestros clientes, se sintió inmediatamente atraída por el acero frente al latón. Comprendimos el potencial de este material y lo combinamos con nuestras competencias técnicas. También se optó por una maquinaria en la que la mano del hombre marca la diferencia, tanto en la elaboración como en el control del producto. La composición del acero 316 le confiere resistencia a todos los cloruros y, por lo tanto, lo hace apto tanto para entornos marinos como para entornos desinfectados con cloro, como las piscinas. En particular, Fontealta utiliza acero 316L, que conserva todas las características del acero inoxidable incluso cuando debe procesarse a altas temperaturas, como en el caso de la soldadura. Somos "especialistas de acero", capaces de adaptar perfectamente la solución de producto a los requisitos de instalación del cliente. Una consideración final importante es que nuestro producto, que es perfecto para exteriores, lo será aún más para un entorno interior, sin exclusión.

EDELSTAHL-SPEZIALISTEN

Unser Unternehmen, das mit der Absicht gegründet wurde, Armaturen für unsere Kunden herzustellen, wandte sich sofort dem Stahl statt dem Messing zu. Wir erkannten das Potenzial dieses Materials und ins Besondere in Kombination mit unserem technischen Know-How. Wir haben uns auch für Maschinen entschieden, bei denen die menschliche Hand den Unterschied macht, sowohl bei der Verarbeitung als auch bei der Kontrolle des Produkts. Die Zusammensetzung von AISI 316 Stahl macht ihn resistent gegen alle Chloride und eignet sich daher sowohl für den Einsatz auf See als auch in chlorhaltigen Umgebungen wie Schwimmbädern. Fontealta verwendet insbesondere 316L-Stahl, der alle Eigenschaften von rostfreiem Stahl beibehält, auch wenn er bei hohen Temperaturen verarbeitet werden muss, wie zum Beispiel beim Schweißen. Wir sind "Stahlspezialisten", die in der Lage sind, die Produktlösung perfekt an die Installationsanforderungen des Kunden anzupassen. Ein wichtiger Aspekt ist, dass unser Produkt, das perfekt für den Außenbereich geeignet ist, ist noch besser für den Innenbereich.

Test di nebbia salina per le nostre colonne in finiture lucida "Supermirror" e spazzolata.

Salt spray test for our columns in bright "Supermirror" and brushed finishes.

Test au brouillard salin pour nos colonnes en finitions brillante "Supermirror" et brossée.

Prueba de niebla salina para nuestras columnas en acabados brillante "Supermirror" y cepillado.

Salzsprühnebeltest für unsere Säulen in den poliertem "Supermirror" und gebürsteter Ausführungen

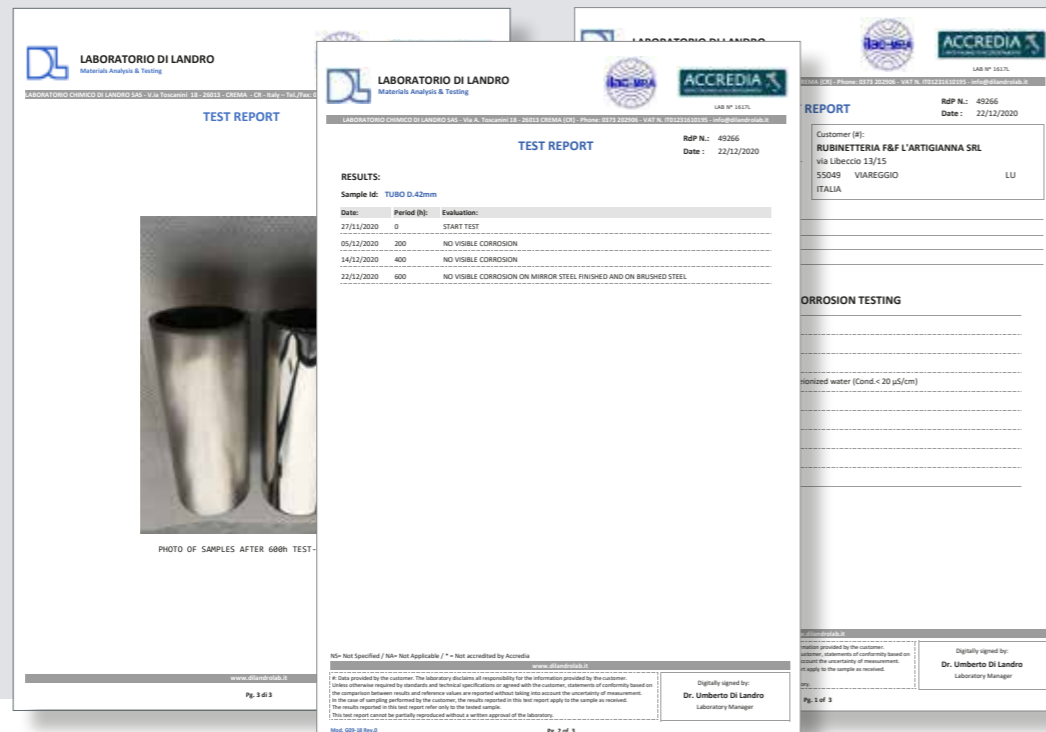

FINITURE | FINISHINGS | FINITIONS | ACABADOS | AUSFÜHRUNGEN

	Lucido Supermirror Polished Supermirror Poli Supermirror Polido Supermirror Poliertem Supermirror	Naturale Natural Naturel Natürlich
	Spazzolato Brushed Brossé Cepillado Gebürsteter	Natural Natürlich
	Nero Opaco Matt Black Noir Matt Negro Mate Matt Schwarz	Verniciato Varnished Vernis Barnizado Lackierter
	RAL a richiesta RAL on request RAL sur requête RAL a petición RAL auf Anfrage	Barnizado Lackierter
	Spazzolato High Brass Brushed High Brass Brossé High Brass Cepillado High Brass Gebürsteter High Brass	
	Spazzolato Copper Brushed Copper Brossé Copper Cepillado Copper Gebürsteter Copper	PVD
	Spazzolato Absolute Black Brushed Absolute Black Brossé Absolute Black Cepillado Absolute Black Gebürsteter Absolute Black	
	Lucido Deep Black Polished Deep Black Poli Deep Black Polido Deep Black Poliertem Deep Black	



INDICE | INDEX | INDICE | ÍNDICE | INDEX

FLAMINGO	<i>pag</i>	9
SKINNY	<i>pag</i>	25
CLASSY	<i>pag</i>	43
TWIGGY	<i>pag</i>	51
BOSS	<i>pag</i>	69
BOSS WIDE	<i>pag</i>	89
ORIGO	<i>pag</i>	97
CLUB	<i>pag</i>	115
CLUB LARGE	<i>pag</i>	123
ORIGO RAME	<i>pag</i>	131
ONDA	<i>pag</i>	134
ARKO	<i>pag</i>	139
SQUARE	<i>pag</i>	143
IN&OUT	<i>pag</i>	147
SPRING	<i>pag</i>	151
COMMUNITY	<i>pag</i>	158
KITCHEN	<i>pag</i>	169
WATERLINE	<i>pag</i>	175
YACHT	<i>pag</i>	189
ACCESSORI	<i>pag</i>	197
INCASSI E INSTALLAZIONI	<i>pag</i>	209



FLAMINGO *pag* 9



SKINNY *pag* 25



CLASSY *pag* 43



TWIGGY *pag* 51

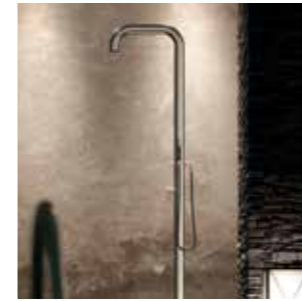

BOSS *pag* 69



BOSS WIDE *pag* 89



ORIGO *pag* 97



CLUB *pag* 115



CLUB LARGE *pag* 123

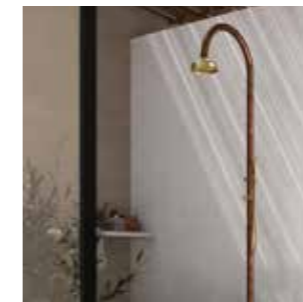

ORIGO RAME *pag* 131



ONDA *pag* 136



ARKO *pag* 140



SQUARE *pag* 143



IN&OUT *pag* 147



SPRING *pag* 151



COMMUNITY *pag* 157



KITCHEN *pag* 169



WATERLINE *pag* 169

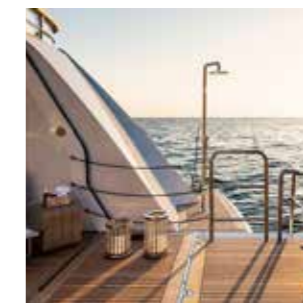

YACHT *pag* 189

ACCESSORIES *pag* 140

CONCEALED BODIES
AND INSTALLATIONS
CONCEALED BODIES
AND INSTALLATIONS
pag 140



FLAMINGO

Basin	<i>pag. 10</i>
Bathtub	<i>pag. 14</i>
Shower	<i>pag. 17</i>



FLAMINGO



F50

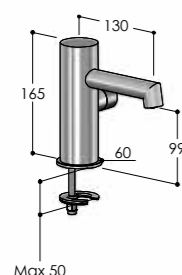

Miscelatore da lavabo
Washbasin mixer
Mitigeur de lavabo
Monomando de lavabo
Waschtischmischer

F50/MX

- F50/BX
- F50/MB
- F50/RL
- F50/BB
- F50/BC
- F50/AB
- F50/DB

F50H

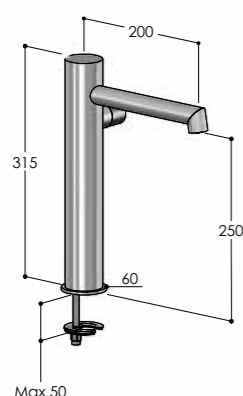

Miscelatore alto da lavabo
Washbasin pillar mixer
Mitigeur haut de lavabo
Monomando de lavabo alto
Waschtischmischer hoch

F50H/MX

- F50H/BX
- F50H/MB
- F50H/RL
- F50H/BB
- F50H/BC
- F50H/AB
- F50H/DB

F50B

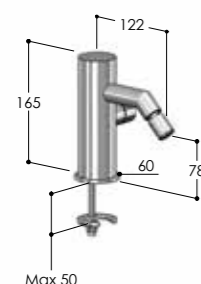

Miscelatore da bidet
Bidet mixer
Mitigeur de bidet
Monomando de bidet
Bidetmischer

F50B/MX

- F50B/BX
- F50B/MB
- F50B/RL
- F50B/BB
- F50B/BC
- F50B/AB
- F50B/DB

W3.F

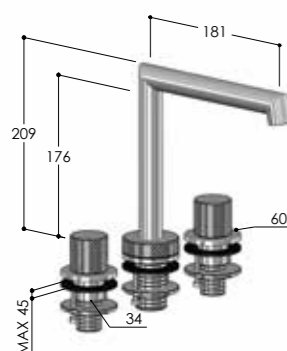

Batteria da lavabo 3 fori
Basin set 3-holes
Mélangeur de lavabo 3 trous
Batería para lavabo 3 agujeros
3-Loch Waschtischbatterie

W3.F/MX

- W3.F/BX
- W3.F/MB
- W3.F/RL
- W3.F/BB
- W3.F/BC
- W3.F/AB
- W3.F/DB



W2M.F



Miscelatore da bordo lavabo
Deck-mounted washbasin mixer
Mitigeur de lavabo, montage sur gorge
Monomando para borde de lavabo
Waschtisch-Batterie für Randmontage

W2M.F/MX

- W2M.F/BX
- W2M.F/MB
- W2M.F/RL
- W2M.F/BB
- W2M.F/BC
- W2M.F/AB
- W2M.F/DB

W3P.F

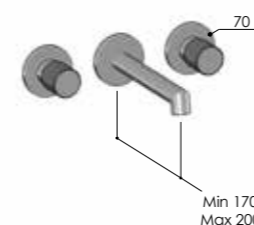

Batteria lavabo da incasso
Concealed washbasin set
Mélangeur lavabo à encastrer
Bateria mural de lavabo
Wandmontierte-Waschtisch-Batterie

Corpo incasso_Concealed body_Corps encastré_Cuerpo empotrado_UP-Teil (pag. 209)

W3P.INC

Parti esterne_External parts_Parties externes_Parties externas_AP-Teile

W3P.F/MX

- W3P.F/BX
- W3P.F/MB
- W3P.F/RL
- W3P.F/BB
- W3P.F/BC
- W3P.F/AB
- W3P.F/DB

W2MP.F

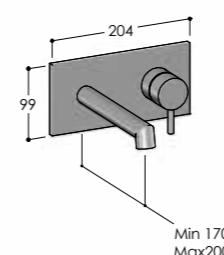

Miscelatore lavabo da incasso
Concealed washbasin mixer
Mitigeur lavabo à encastrer
Monomando mural de lavabo
UP-Waschtisch-Einhandbatterie

Corpo incasso_Concealed body_Corps encastré_Cuerpo empotrado_UP-Teil (pag. 209)

W2MP.INC

Parti esterne_External parts_Parties externes_Parties externas_AP-Teile

W2MP.F/MX

- W2MP.F/BX
- W2MP.F/MB
- W2MP.F/RL
- W2MP.F/BB
- W2MP.F/BC
- W2MP.F/AB
- W2MP.F/DB

W2MP.2.F

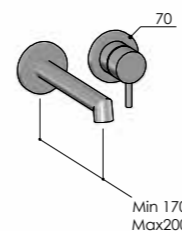

Miscelatore lavabo da incasso
Concealed washbasin mixer
Mitigeur lavabo à encastrer
Monomando mural de lavabo
UP-Waschtisch-Einhandbatterie

Corpo incasso_Concealed body_Corps encastré_Cuerpo empotrado_UP-Teil (pag. 209)

W2MP.2.F/MX

Parti esterne_External parts_Parties externes_Parties externas_AP-Teile

W2MP.2.F/MX

- W2MP.2.F/BX
- W2MP.2.F/MB
- W2MP.2.F/RL
- W2MP.2.F/BB
- W2MP.2.F/BC
- W2MP.2.F/AB
- W2MP.2.F/DB



WMRL



Miscelatore da incasso per lavabo
 Concealed mixer for washbasin
 Mitiguer encastrable pour lavabo
 Monomando empotrado para lavabo
 Waschtischmischer

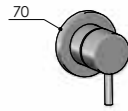

Corpo incasso_Concealed body_Corps encastré_Cuerpo empotrado_UP-Teil (pag. 209)

MR.INC

Parti esterne_External parts_Parties externes_Parties externas_AP-Teile

WMRL/MX

- WMRL/BX
- WMRL/MB
- WMRL/RL
- WMRL/BB
- WMRL/BC
- WMRL/AB
- WMRL/DB

SP.F

Bocca a parete
 Wall-mounted spout
 Bec déverseur
 Caño mural
 Wandmontierter Wanneneinlauf

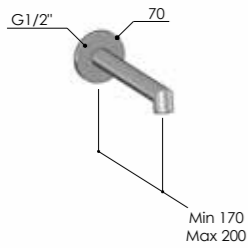

SP.F/MX

- SP.F/BX
- SP.F/MB
- SP.F/RL
- SP.F/BB
- SP.F/BC
- SP.F/AB
- SP.F/DB



F60L.RC

Colonna per lavabo per comando remoto
 Washbasin column for remote control
 Colonne pour lavabo pour commande à distance
 Column de lavabo para control remoto
 Waschtischsäule für Fernsteuerung

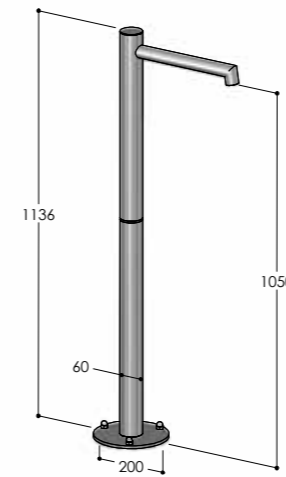

F60L.RC/MX

- F60L.RC/BX
- F60L.RC/MB
- F60L.RC/RL
- F60L.RC/BB
- F60L.RC/BC
- F60L.RC/AB
- F60L.RC/DB

Corpo incasso_Concealed body_Corps encastré_Cuerpo empotrado_UP-Teil (pag. 209)

CW.2

Parti esterne_External parts_Parties externes_Parties externas_AP-Teile

F60L.XCW.RC/MX

- F60L.XCW.RC/BX
- F60L.XCW.RC/MB
- F60L.XCW.RC/RL
- F60L.XCW.RC/BB
- F60L.XCW.RC/BC
- F60L.XCW.RC/AB
- F60L.XCW.RC/DB

F60L.M



Colonna per lavabo con miscelatore
 Washbasin column with mixer
 Colonne pour lavabo avec mitigeur
 Column de lavabo con monomando
 Waschtischsäule mit Einhebelmischer

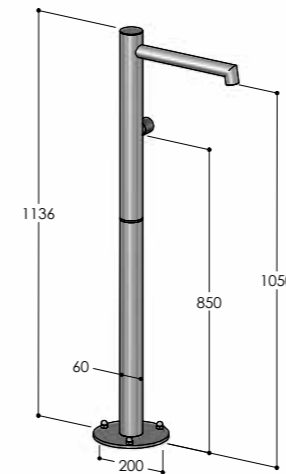

F60L.M/MX

- F60L.M/BX
- F60L.M/MB
- F60L.M/RL
- F60L.M/BB
- F60L.M/BC
- F60L.M/AB
- F60L.M/DB

Corpo incasso_Concealed body_Corps encastré_Cuerpo empotrado_UP-Teil (pag. 209)

CW.2

Parti esterne_External parts_Parties externes_Parties externas_AP-Teile

F60L.XCW.M/MX

- F60L.XCW.M/BX
- F60L.XCW.M/MB
- F60L.XCW.M/RL
- F60L.XCW.M/BB
- F60L.XCW.M/BC
- F60L.XCW.M/AB
- F60L.XCW.M/DB

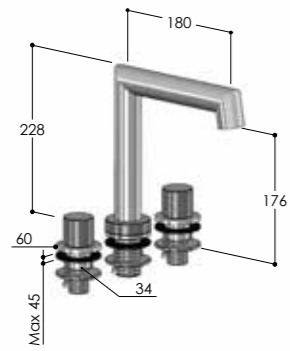

W3B.F

Batteria bordo vasca 3 fori
Bathtub set 3-holes
Mélangeur de baignoire pour montage sur gorge, 3 trous
Bateria para borde de bañera, 3 agujeros
3-Loch Badewannenbatterie für Randmontage

W3B.F/MX

- W3B.F/BX
- W3B.F/MB
- W3B.F/RL
- W3B.F/BB
- W3B.F/BC
- W3B.F/AB
- W3B.F/DB

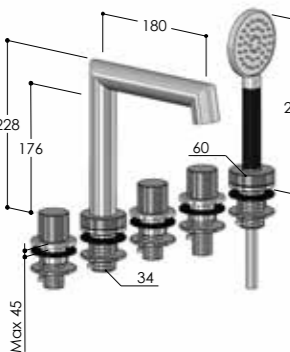

W5B.F

Batteria bordo vasca 5 fori
Bathtub set 5-holes
Mélangeur de baignoire pour montage sur gorge, 3 trous
Bateria para borde de bañera, 5 agujeros
5-Loch Badewannenbatterie für Randmontage

W5B.F/MX

- W5B.F/BX
- W5B.F/MB
- W5B.F/RL
- W5B.F/BB
- W5B.F/BC
- W5B.F/AB
- W5B.F/DB



W2MB.F

Miscelatore per bordo vasca
Deck-mounted bathtub mixer
Mitigeur de baignoire pour montage sur gorge
Monomando de repisa para bañera
Badewannenmischer für Randmontage

W2MB.F/MX

- W2MB.F/BX
- W2MB.F/MB
- W2MB.F/RL
- W2MB.F/BB
- W2MB.F/BC
- W2MB.F/AB
- W2MB.F/DB



W4MB.F

Miscelatore per bordo vasca con doccia
Deck-mounted bathtub mixer with handshower
Mitigeur de baignoire pour montage sur gorge avec douche
Monomando de repisa para bañera con teleducha
Badewannenmischer für Randmontage mit Handbrause

W4MB.F/MX

- W4MB.F/BX
- W4MB.F/MB
- W4MB.F/RL
- W4MB.F/BB
- W4MB.F/BC
- W4MB.F/AB
- W4MB.F/DB

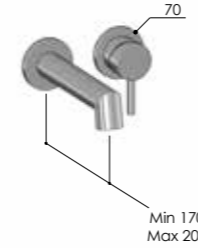

W2MBP.F

Miscelatore bordo vasca da incasso
Concealed bathtub mixer
Mélangeur pour baignoire encastrable
Monomando empotrado de bañera
UP-Badewannenmischer

Corpo incasso_Concealed body_Corps encastré_Cuerpo empotrado_UP-Teil (pag. 209)

W2MP.INC

Parti esterne_External parts_Parties externes_Parties externas_AP-Teile

W2MBP.F/MX

- W2MBP.F/BX
- W2MBP.F/MB
- W2MBP.F/RL
- W2MBP.F/BB
- W2MBP.F/BC
- W2MBP.F/AB
- W2MBP.F/DB



W3MBP.F

Miscelatore bordo vasca da incasso con doccia
Concealed bathtub mixer with handshower
Mélangeur pour baignoire encastrable avec douche
Monomando empotrado de bañera con teleducha
UP-Badewannenmischer mit Handbrause

Corpo incasso_Concealed body_Corps encastré_Cuerpo empotrado_UP-Teil (pag. 209)

W3MP.INC

Parti esterne_External parts_Parties externes_Parties externas_AP-Teile

W3MBP.F/MX

- W3MBP.F/BX
- W3MBP.F/MB
- W3MBP.F/RL
- W3MBP.F/BB
- W3MBP.F/BC
- W3MBP.F/AB
- W3MBP.F/DB

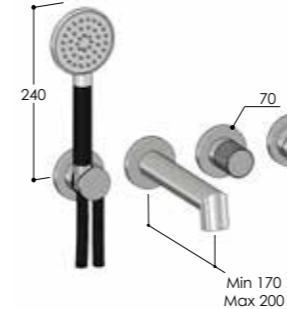

W4MBP.F

Miscelatore bordo vasca da incasso con doccia
Concealed bathtub mixer with handshower
Mélangeur pour baignoire encastrable avec douche
Monomando empotrado de bañera con teleducha
UP-Badewannenmischer mit Handbrause

Corpo incasso_Concealed body_Corps encastré_Cuerpo empotrado_UP-Teil (pag. 209)

W4MP.INC

Parti esterne_External parts_Parties externes_Parties externas_AP-Teile

W4MBP.F/MX

- W4MBP.F/BX
- W4MBP.F/MB
- W4MBP.F/RL
- W4MBP.F/BB
- W4MBP.F/BC
- W4MBP.F/AB
- W4MBP.F/DB

F60V.RC

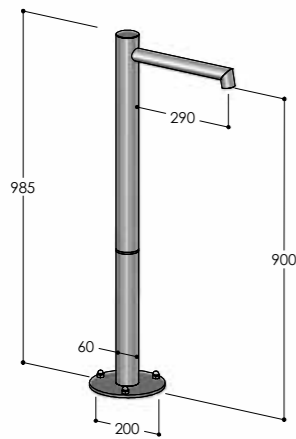

Colonna per vasca per comando remoto
Bathtub column for remote control
Colonne pour baignoire pour commande à distance
Column de bañera para control remoto
Badewannensäule für Fernsteuerung

✓	F60V.RC/MX
	F60V.RC/BX
	F60V.RC/MB
	F60V.RC/RL
	F60V.RC/BB
	F60V.RC/BC
F60V.RC/AB	
F60V.RC/DB	
CW	Corpo incasso_Concealed body_Corps encastré_Cuerpo empotrado_UP-Teil (pag. 209)
	CW.2
	Parti esterne_External parts_Parties externes_Parties externas_AP-Teile
	F60V.XCW.RC/MX
	F60V.XCW.RC/BX
	F60V.XCW.RC/MB
	F60V.XCW.RC/RL
	F60V.XCW.RC/BB
	F60V.XCW.RC/BC
	F60V.XCW.RC/AB
	F60V.XCW.RC/DB

F60V.M

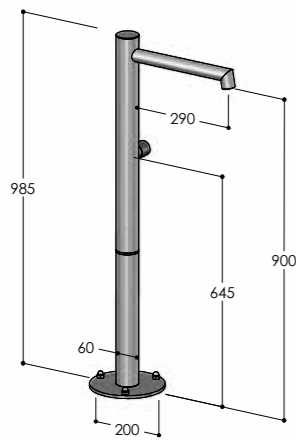

Colonna per vasca con miscelatore
Bathtub column with mixer
Colonne pour baignoire avec mitigeur
Column de bañera con monomando
Badewannensäule mit Einhebelmischer

✓	F60V.M/MX
	F60V.M/BX
	F60V.M/MB
	F60V.M/RL
	F60V.M/BB
	F60V.M/BC
	F60V.M/AB
	F60V.M/DB
CW	Corpo incasso_Concealed body_Corps encastré_Cuerpo empotrado_UP-Teil (pag. 209)
	CW.2
	Parti esterne_External parts_Parties externes_Parties externas_AP-Teile
	F60V.XCW.M/MX
	F60V.XCW.M/BX
	F60V.XCW.M/MB
	F60V.XCW.M/RL
	F60V.XCW.M/BB
	F60V.XCW.M/BC
	F60V.XCW.M/AB
	F60V.XCW.M/DB

F60V.ME

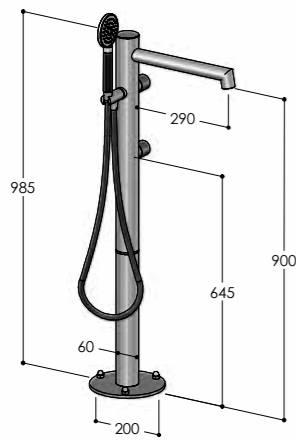

Colonna per vasca con miscelatore e doccia
Bathtub column with mixer and handshower
Colonne pour baignoire avec mitigeur et douche
Column de bañera con monomando y teleducha
Badewannensäule mit Einhebelmischer und Handbrause

✓	F60V.ME/MX
	F60V.ME/BX
	F60V.ME/MB
	F60V.ME/RL
	F60V.ME/BB
	F60V.ME/BC
	F60V.ME/AB
	F60V.ME/DB
CW	Corpo incasso_Concealed body_Corps encastré_Cuerpo empotrado_UP-Teil (pag. 209)
	CW.2
	Parti esterne_External parts_Parties externes_Parties externas_AP-Teile
	F60V.XCW.ME/MX
	F60V.XCW.ME/BX
	F60V.XCW.ME/MB
	F60V.XCW.ME/RL
	F60V.XCW.ME/BB
	F60V.XCW.ME/BC
	F60V.XCW.ME/AB
	F60V.XCW.ME/DB

ST.F

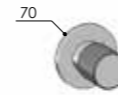

Rubinetto incasso
Concealed tap
Robinet d'arrêt encastrable
Llave de paso
UP-Ventil

Corpo incasso_Concealed body_Corps encastré_Cuerpo empotrado_UP-Teil (pag. 209)

ST.INC

Parti esterne_External parts_Parties externes_Parties externas_AP-Teile

ST.F/MX

ST.F/BX

ST.F/MB

ST.F/RL

ST.F/BB

ST.F/BC

ST.F/AB

ST.F/DB

MR

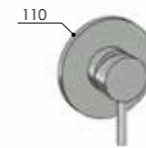

Miscelatore da incasso per doccia
Concealed shower mixer
Mitigeur de douche à encastrer
Monomando de ducha mural
UP-Brausemischer

Corpo incasso_Concealed body_Corps encastré_Cuerpo empotrado_UP-Teil (pag. 209)

MR.INC

Parti esterne_External parts_Parties externes_Parties externas_AP-Teile

MR/MX

MR/BX

MR/MB

MR/RL

MR/BB

MR/BC

MR/AB

MR/DB

MR2.F

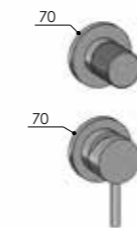

Miscelatore da incasso per doccia, con deviatore a 2 vie
Concealed shower mixer with 2-ways diverter
Mitigeur de douche encastrable avec inverseur à 2 voies
Monomando empotrado para ducha con desviador 2 salidas
UP-Brausemischer mit 2-Wege Umsteller

Corpo incasso_Concealed body_Corps encastré_Cuerpo empotrado_UP-Teil (pag. 209)

MR2.INC

Parti esterne_External parts_Parties externes_Parties externas_AP-Teile

MR2.F/MX

MR2.F/BX

MR2.F/MB

MR2.F/RL

MR2.F/BB

MR2.F/BC

MR2.F/AB

MR2.F/DB

MR3.F

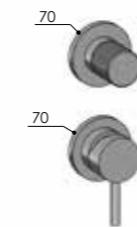

Miscelatore da incasso per doccia, con deviatore a 3 vie
Concealed shower mixer with 3-ways diverter
Mitigeur de douche encastrable avec inverseur à 3 voies
Monomando empotrado para ducha con desviador 3 salidas
UP-Brausemischer mit 3-Wege Umsteller

Corpo incasso_Concealed body_Corps encastré_Cuerpo empotrado_UP-Teil (pag. 209)

MR3.INC

Parti esterne_External parts_Parties externes_Parties externas_AP-Teile

MR3.F/MX

MR3.F/BX

MR3.F/MB

MR3.F/RL

MR3.F/BB

MR3.F/BC

MR3.F/AB

MR3.F/DB

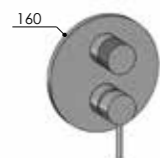

MX2.F



Miscelatore da incasso per doccia, con deviatore a 2 vie
 Concealed shower mixer with 2-ways diverter
 Mitigeur de douche encastrable avec inverseur à 2 voies
 Monomando empotrado para ducha con desviador 2 salidas
 UP-Brausemischer mit 2-Wege Umsteller

Corpo incasso_Concealed body_Corps encastré_Cuerpo empotrado_UP-Teil (pag. 209)

MX.INC

Parti esterne_External parts_Parties externes_Parties externas_AP-Teile

MX2.F/MX

- MX2.F/BX
- MX2.F/MB
- MX2.F/RL
- MX2.F/BB
- MX2.F/BC
- MX2.F/AB
- MX2.F/DB

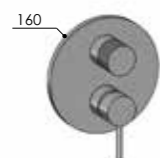

MX3.F



Miscelatore da incasso per doccia, con deviatore a 3 vie
 Concealed shower mixer with 3-ways diverter
 Mitigeur de douche encastrable avec inverseur à 3 voies
 Monomando empotrado para ducha con desviador 3 salidas
 UP-Brausemischer mit 3-Wege Umsteller

Corpo incasso_Concealed body_Corps encastré_Cuerpo empotrado_UP-Teil (pag. 209)

MX.INC

Parti esterne_External parts_Parties externes_Parties externas_AP-Teile

MX3.F/MX

- MX3.F/BX
- MX3.F/MB
- MX3.F/RL
- MX3.F/BB
- MX3.F/BC
- MX3.F/AB
- MX3.F/DB

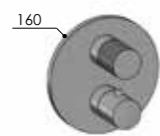

TC1.F



Miscelatore termostatico da incasso per doccia
 Concealed thermostatic mixer for shower
 Mitigeur thermostatique de douche
 Mezclador termostatico empotrado para ducha
 UP-Thermostat-Brausemischer

Corpo incasso_Concealed body_Corps encastré_Cuerpo empotrado_UP-Teil (pag. 209)

MX.INC

Parti esterne_External parts_Parties externes_Parties externas_AP-Teile

TC1.F/MX

- TC1.F/BX
- TC1.F/MB
- TC1.F/RL
- TC1.F/BB
- TC1.F/BC
- TC1.F/AB
- TC1.F/DB

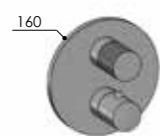

TC2.F



Miscelatore termostatico da incasso per doccia, 2 vie
 Concealed thermostatic mixer for shower, 2-ways
 Mitigeur thermostatique de douche, 2-voies
 Mezclador termostatico empotrado para ducha, 2-salidas
 UP-Thermostat-Brausemischer, 2-Wege

Corpo incasso_Concealed body_Corps encastré_Cuerpo empotrado_UP-Teil (pag. 209)

MX.INC

Parti esterne_External parts_Parties externes_Parties externas_AP-Teile

TC2.F/MX

- TC2.F/BX
- TC2.F/MB
- TC2.F/RL
- TC2.F/BB
- TC2.F/BC
- TC2.F/AB
- TC2.F/DB

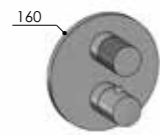

TC3.F



Miscelatore termostatico da incasso per doccia, 3 vie
 Concealed thermostatic mixer for shower, 3-ways
 Mitigeur thermostatique de douche, 3-voies
 Mezclador termostatico empotrado para ducha, 3-salidas
 UP-Thermostat-Brausemischer, 3-Wege

Corpo incasso_Concealed body_Corps encastré_Cuerpo empotrado_UP-Teil (pag. 209)

MX.INC

Parti esterne_External parts_Parties externes_Parties externas_AP-Teile

TC3.F/MX

- TC3.F/BX
- TC3.F/MB
- TC3.F/RL
- TC3.F/BB
- TC3.F/BC
- TC3.F/AB
- TC3.F/DB

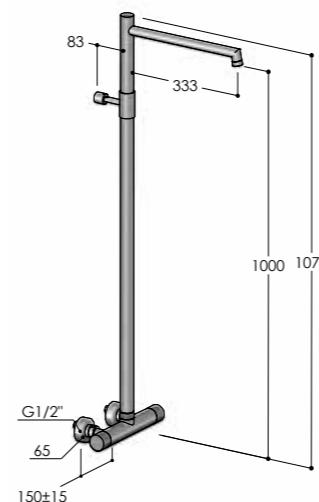

W564



Gruppo esterno con colonna doccia e soffione incassato
 Wall-mounted shower mixer, with column and concealed showerhead
 Mélangeur douche avec colonne et pomme de douche intégrée
 Batería para ducha con columna y rociador integrado
 AP-Brausebatterie mit Stange und integrierter Kopfbrause

W564/MX

- W564/BX
- W564/MB
- W564/RL
- W564/BB
- W564/BC
- W564/AB
- W564/DB

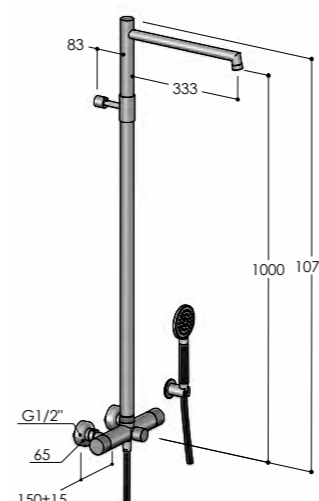

W564.E



Gruppo esterno con colonna doccia, soffione incassato e doccia
 Wall-mounted shower mixer, with column, concealed showerhead and handshower
 Mélangeur douche avec colonne, pomme de douche intégrée et douchette
 Batería para ducha con columna, rociador integrado y teleducha
 AP-Brausebatterie mit Stange, integrierter Kopfbrause und Handbrause

W564.E/MX

- W564.E/BX
- W564.E/MB
- W564.E/RL
- W564.E/BB
- W564.E/BC
- W564.E/AB
- W564.E/DB

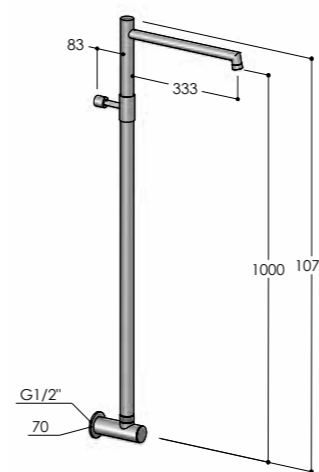

W5X7

Pres a d'acqua con colonna doccia e soffione incassato
 Wall coupling, with column and concealed showerhead
 Coude de sortie, avec colonne et pomme de douche intégrée
 Codo mural, con columna y rociador integrado
 Wandanschlußbogen mit Stange und integrierter Kopfbrause

W5X7/MX

- W5X7/BX
- W5X7/MB
- W5X7/RL
- W5X7/BB
- W5X7/BC
- W5X7/AB
- W5X7/DB

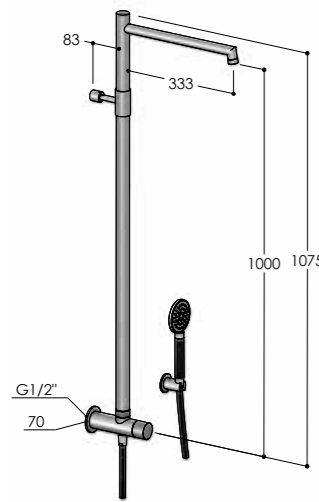

W569.E



Presad'acqua con colonna doccia, soffione incassato e doccia
 Wall coupling, with column, concealed showerhead and handshower
 Coude de sortie, avec colonne, pomme de douche intégrée et douchette
 Codo mural, con columna, rociador integrado y teleducha
 Wandanschlußbogen mit Stange, integrierter Kopfbrause und Handbrause

- W569.E/MX**
 W569.E/BX
 W569.E/MB
 W569.E/RL
 W569.E/BB
 W569.E/BC
 W569.E/AB
 W569.E/DB

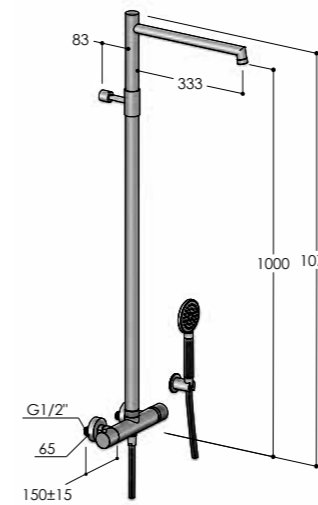

W56A6.E



Miscelatore termostatico esterno con colonna doccia, soffione incassato e doccia
 Wall-mounted thermostatic mixer, with column, concealed showerhead and handshower
 Mitigeur thermostatique mural avec colonne, pomme de douche intégrée et douchette
 Mezclador termostatico mural con columna, rociador integrado y teleducha
 AP-Thermostat-Brausemischer mit Stange, integrierter Kopfbrause und Handbrause

- W56A6.E/MX**
 W56A6.E/BX
 W56A6.E/MB
 W56A6.E/RL
 W56A6.E/BB
 W56A6.E/BC
 W56A6.E/AB
 W56A6.E/DB

W567C

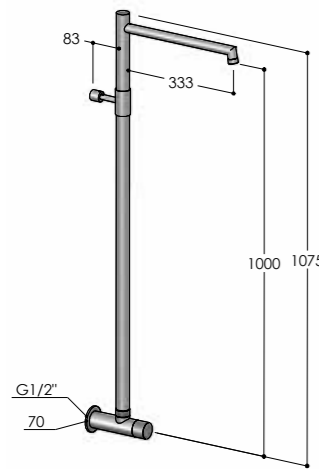

Rubinetto esterno con colonna doccia e soffione incassato
 Wall-mounted tap with column and concealed showerhead
 Robinet mural avec colonne et pomme de douche intégrée
 Grifo mural con columna y rociador integrado
 AP-Ventil mit Stange und integrierter Kopfbrause

- W567C/MX**
 W567C/BX
 W567C/MB
 W567C/RL
 W567C/BB
 W567C/BC
 W567C/AB
 W567C/DB

W569C.E

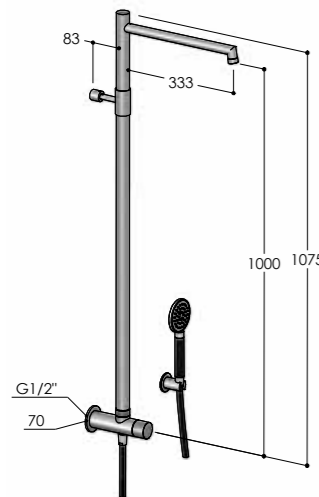

Rubinetto esterno con colonna doccia, soffione incassato e doccia
 Wall-mounted tap with column, concealed showerhead and handshower
 Robinet mural avec colonne, pomme de douche intégrée et douchette
 Grifo mural con columna, rociador integrado y teleducha
 AP-Ventil mit Stange, integrierter Kopfbrause und Handbrause

- W569C.E/MX**
 W569C.E/BX
 W569C.E/MB
 W569C.E/RL
 W569C.E/BB
 W569C.E/BC
 W569C.E/AB
 W569C.E/DB

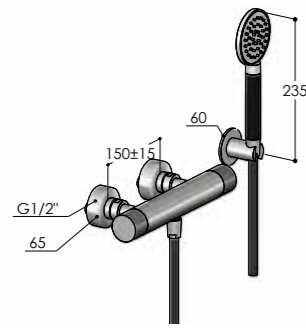

WX64.SK



Gruppo esterno con kit doccia
Wall-mounted mixer with shower kit
Mélangeur mural avec kit de douche
Bateria con kit de ducha mural
AP-Batterie mit Brausekit

WX64.SK/MX

- WX64.SK/BX
- WX64.SK/MB
- WX64.SK/RL
- WX64.SK/BB
- WX64.SK/BC
- WX64.SK/AB
- WX64.SK/DB

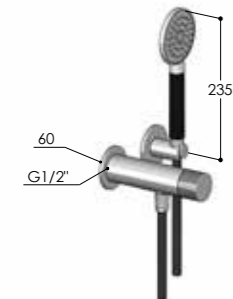

WX67C.SK



Rubinetto esterno con kit doccia
Wall-mounted tap with shower kit
Robinet mural avec kit de douche
Grifo mural con kit de ducha
AP-Ventil, mit Brausekit

WX67C.SK/MX

- WX67C.SK/BX
- WX67C.SK/MB
- WX67C.SK/RL
- WX67C.SK/BB
- WX67C.SK/BC
- WX67C.SK/AB
- WX67C.SK/DB

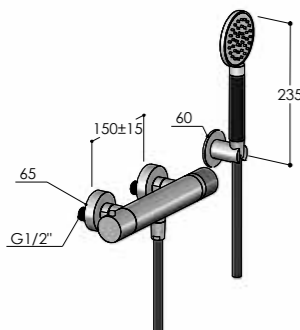

WX6A6.SK



Miscelatore termostatico esterno con kit doccia
Wall-mounted thermostatic mixer with shower kit
Mitigeur thermostatique mural avec kit de douche
Mezclador termostatico mural con kit de ducha
AP-Thermostat-Brausemischer mit Brausekit

WX6A6.SK/MX

- WX6A6.SK/BX
- WX6A6.SK/MB
- WX6A6.SK/RL
- WX6A6.SK/BB
- WX6A6.SK/BC
- WX6A6.SK/AB
- WX6A6.SK/DB

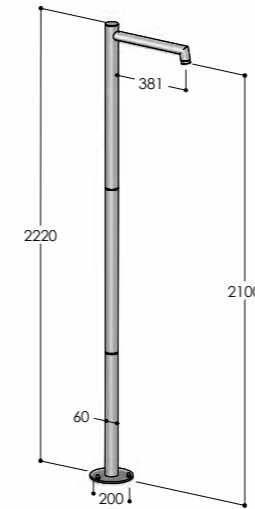

F60.RC

Colonna doccia con soffione incassato per comando remoto
Shower column with concealed showerhead for remote control
Colonne douche avec pomme de douche intégrée pour commande à distance
Column de ducha con rociador integrado para control remoto
Duschsäule mit integrierter Kopfbrause für Fernsteuerung

F60.RC/MX

- F60.RC/BX
- F60.RC/MB
- F60.RC/RL
- F60.RC/BB
- F60.RC/BC
- F60.RC/AB
- F60.RC/DB

Corpo incasso_Concealed body_Corps encastré_Cuerpo empotrado_UP-Teil (pag. 209)

CW.1

Parti esterne_External parts_Parties externes_Parties externas_AP-Teile

F60.XCW.RC/MX

- F60.XCW.RC/BX
- F60.XCW.RC/MB
- F60.XCW.RC/RL
- F60.XCW.RC/BB
- F60.XCW.RC/BC
- F60.XCW.RC/AB
- F60.XCW.RC/DB

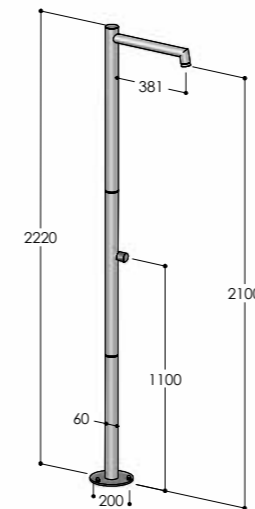

F60.M



Colonna doccia con miscelatore e soffione incassato
Shower column with mixer and concealed showerhead
Colonne douche avec mitigeur et pomme de douche intégrée
Column de ducha con monomando y rociador integrado
Duschsäule mit Einhebelmischer und integrierter Kopfbrause

F60.M/MX

- F60.M/BX
- F60.M/MB
- F60.M/RL
- F60.M/BB
- F60.M/BC
- F60.M/AB
- F60.M/DB

Corpo incasso_Concealed body_Corps encastré_Cuerpo empotrado_UP-Teil (pag. 209)

CW.2

Parti esterne_External parts_Parties externes_Parties externas_AP-Teile

F60.XCW.M/MX

- F60.XCW.M/BX
- F60.XCW.M/MB
- F60.XCW.M/RL
- F60.XCW.M/BB
- F60.XCW.M/BC
- F60.XCW.M/AB
- F60.XCW.M/DB

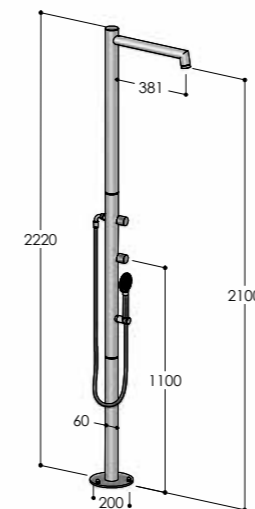

F60.ME



Colonna doccia con miscelatore, soffione incassato e doccia
Shower column with mixer, concealed showerhead and handshower
Colonne douche avec mitigeur, pomme de douche intégrée et douchette
Column de ducha con monomando, rociador integrado y teleducha
Duschsäule mit Einhebelmischer, integrierter Kopfbrause und Handbrause

F60.ME/MX

- F60.ME/BX
- F60.ME/MB
- F60.ME/RL
- F60.ME/BB
- F60.ME/BC
- F60.ME/AB
- F60.ME/DB

Corpo incasso_Concealed body_Corps encastré_Cuerpo empotrado_UP-Teil (pag. 209)

CW.2

Parti esterne_External parts_Parties externes_Parties externas_AP-Teile

F60.XCW.ME/MX

- F60.XCW.ME/BX
- F60.XCW.ME/MB
- F60.XCW.ME/RL
- F60.XCW.ME/BB
- F60.XCW.ME/BC
- F60.XCW.ME/AB
- F60.XCW.ME/DB



SKINNY

Basin	<i>pag. 26</i>
Bathtub	<i>pag. 30</i>
Shower	<i>pag. 35</i>





W35

Miscelatore da lavabo
Washbasin mixer
Mitigeur de lavabo
Monomando de lavabo
Waschtischmischer

W35/MX

- W35/BX
- W35/MB
- W35/RL
- W35/BB
- W35/BC
- W35/AB
- W35/DB

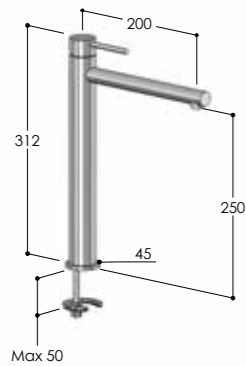

W35H

Miscelatore alto da lavabo
Washbasin pillar mixer
Mitigeur haut de lavabo
Monomando de lavabo alto
Waschtischmischer hoch

W35H/MX

- W35H/BX
- W35H/MB
- W35H/RL
- W35H/BB
- W35H/BC
- W35H/AB
- W35H/DB

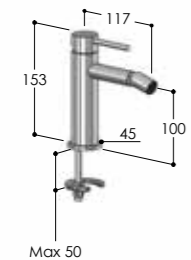

W35B

Miscelatore da bidet
Bidet mixer
Mitigeur de bidet
Monomando de bidet
Bidetmischer

W35B/MX

- W35B/BX
- W35B/MB
- W35B/RL
- W35B/BB
- W35B/BC
- W35B/AB
- W35B/DB

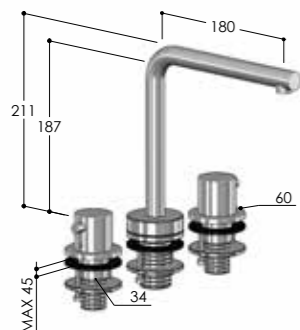

W3.L

Batteria da lavabo 3 fori
Basin set 3-holes
Mélangeur de lavabo 3 trous
Batería para lavabo 3 agujeros
3-Loch Waschtischbatterie

W3.L/MX

- W3.L/BX
- W3.L/MB
- W3.L/RL
- W3.L/BB
- W3.L/BC
- W3.L/AB
- W3.L/DB

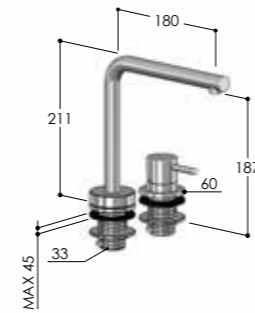

W2M.L

Miscelatore da bordo lavabo
Deck-mounted washbasin mixer
Mitigeur de lavabo, montage sur gorge
Monomando para borde de lavabo
Waschtisch-Batterie für Randmontage

W2M.L/MX

- W2M.L/BX
- W2M.L/MB
- W2M.L/RL
- W2M.L/BB
- W2M.L/BC
- W2M.L/AB
- W2M.L/DB

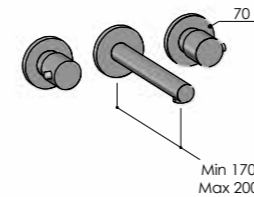

W3P.L

Batteria lavabo da incasso
Concealed washbasin set
Mélangeur lavabo à encastrer
Bateria mural de lavabo
Wandmontierte-Waschtisch-Batterie

Corpo incasso_Concealed body_Corps encastré_Cuerpo empotrado_UP-Teil (pag. 209)

W3P.INC

Parti esterne_External parts_Parties externes_Parties externas_AP-Teile

W3P.L/MX

- W3P.L/BX
- W3P.L/MB
- W3P.L/RL
- W3P.L/BB
- W3P.L/BC
- W3P.L/AB
- W3P.L/DB

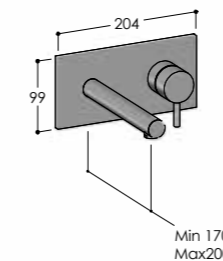

W2MP.L

Miscelatore lavabo da incasso
Concealed washbasin mixer
Mitigeur lavabo à encastrer
Monomando mural de lavabo
UP-Waschtisch-Einhandbatterie

Corpo incasso_Concealed body_Corps encastré_Cuerpo empotrado_UP-Teil (pag. 209)

W2MP.INC

Parti esterne_External parts_Parties externes_Parties externas_AP-Teile

W2MP.L/MX

- W2MP.L/BX
- W2MP.L/MB
- W2MP.L/RL
- W2MP.L/BB
- W2MP.L/BC
- W2MP.L/AB
- W2MP.L/DB

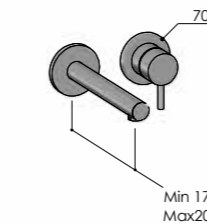

W2MP.2.L

Miscelatore lavabo da incasso
Concealed washbasin mixer
Mitigeur lavabo à encastrer
Monomando mural de lavabo
UP-Waschtisch-Einhandbatterie

Corpo incasso_Concealed body_Corps encastré_Cuerpo empotrado_UP-Teil (pag. 209)

W2MP.INC

Parti esterne_External parts_Parties externes_Parties externas_AP-Teile

W2MP.2.L/MX

- W2MP.2.L/BX
- W2MP.2.L/MB
- W2MP.2.L/RL
- W2MP.2.L/BB
- W2MP.2.L/BC
- W2MP.2.L/AB
- W2MP.2.L/DB



WMRL



Miscelatore da incasso per lavabo
 Concealed mixer for washbasin
 Mitiguer encastrable pour lavabo
 Monomando empotrado para lavabo
 Waschtischmischer

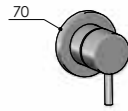

Corpo incasso_Concealed body_Corps encastré_Cuerpo empotrado_UP-Teil (pag. 209)

MR.INC

Parti esterne_External parts_Parties externes_Parties externas_AP-Teile

WMRL/MX

- WMRL/BX
- WMRL/MB
- WMRL/RL
- WMRL/BB
- WMRL/BC
- WMRL/AB
- WMRL/DB

SP.L

Bocca a parete
 Wall-mounted spout
 Bec déverseur
 Caño mural
 Wandmontierter Wanneneinlauf

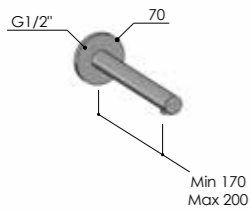

SP.L/MX

- SP.L/BX
- SP.L/MB
- SP.L/RL
- SP.L/BB
- SP.L/BC
- SP.L/AB
- SP.L/DB



S40L.RC

Colonna per lavabo per comando remoto
 Washbasin column for remote control
 Colonne pour lavabo pour commande à distance
 Column de lavabo para control remoto
 Waschtischsäule für Fernsteuerung

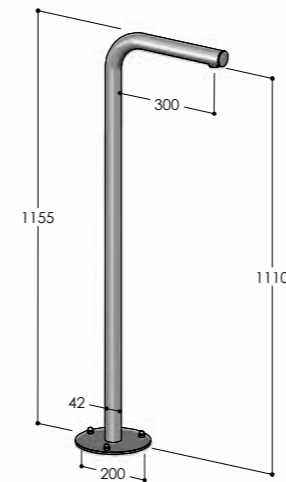

S40L.RC/MX

- S40L.RC/BX
- S40L.RC/MB
- S40L.RC/RL

Corpo incasso_Concealed body_Corps encastré_Cuerpo empotrado_UP-Teil (pag. 209)

CW.1

- Parti esterne_External parts_Parties externes_Parties externas_AP-Teile
- S40L.XCW.RC/MX**
- S40L.XCW.RC/BX
- S40L.XCW.RC/MB
- S40L.XCW.RC/RL

S40L

Colonna per lavabo con rubinetto d'arresto
 Washbasin column with stop tap
 Colonne pour lavabo avec robinet d'arrêt
 Column de lavabo con grifo
 Waschtischsäule mit Wasserhahn

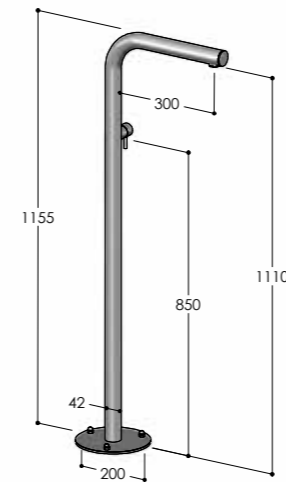

S40L/MX

- S40L/BX
- S40L/MB
- S40L/RL

Corpo incasso_Concealed body_Corps encastré_Cuerpo empotrado_UP-Teil (pag. 209)

CW.1

- Parti esterne_External parts_Parties externes_Parties externas_AP-Teile
- S40L.XCW/MX**
- S40L.XCW/BX
- S40L.XCW/MB
- S40L.XCW/RL

S40L.M

Colonna per lavabo con miscelatore
 Washbasin column with mixer
 Colonne pour lavabo avec mitigeur
 Column de lavabo con monomando
 Waschtischsäule mit Einhebelmischer

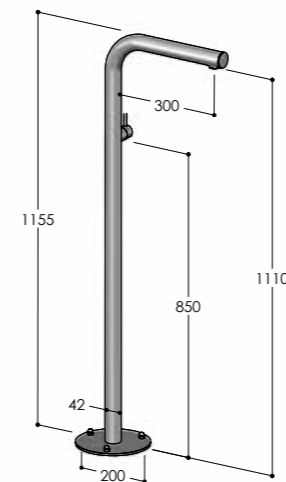

S40L.M/MX

- S40L.M/BX
- S40L.M/MB
- S40L.M/RL

Corpo incasso_Concealed body_Corps encastré_Cuerpo empotrado_UP-Teil (pag. 209)

CW.2

- Parti esterne_External parts_Parties externes_Parties externas_AP-Teile
- S40L.XCW.M/MX**
- S40L.XCW.M/BX
- S40L.XCW.M/MB
- S40L.XCW.M/RL



W3B.L

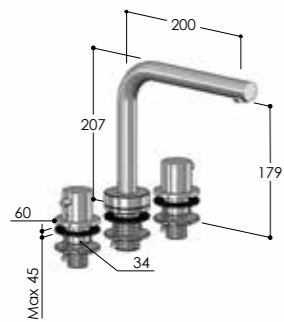

Batteria bordo vasca 3 fori
Bathtub set 3-holes
Mélangeur de baignoire pour montage sur gorge, 3 trous
Bateria para borde de bañera, 3 agujeros
3-Loch Badewannenbatterie für Randmontage

W3B.L/MX

- W3B.L/BX
- W3B.L/MB
- W3B.L/RL
- W3B.L/BB
- W3B.L/BC
- W3B.L/AB
- W3B.L/DB

W5B.L



Batteria bordo vasca 5 fori
Bathtub set 5-holes
Mélangeur de baignoire pour montage sur gorge, 5 trous
Bateria para borde de bañera, 5 agujeros
5-Loch Badewannenbatterie für Randmontage

W5B.L/MX

- W5B.L/BX
- W5B.L/MB
- W5B.L/RL
- W5B.L/BB
- W5B.L/BC
- W5B.L/AB
- W5B.L/DB

W2MB.L



Miscelatore per bordo vasca
Deck-mounted bathtub mixer
Mitigeur de baignoire pour montage sur gorge
Monomando de repisa para bañera
Badewannenmischer für Randmontage

W2MB.L/MX

- W2MB.L/BX
- W2MB.L/MB
- W2MB.L/RL
- W2MB.L/BB
- W2MB.L/BC
- W2MB.L/AB
- W2MB.L/DB

W4MB.L

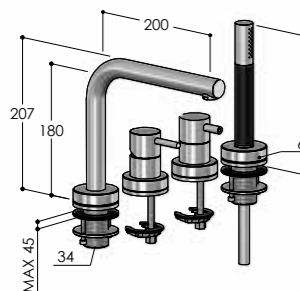

Miscelatore per bordo vasca con doccia
Deck-mounted bathtub mixer with handshower
Mitigeur de baignoire pour montage sur gorge avec douche
Monomando de repisa para bañera con teleducha
Badewannenmischer für Randmontage mit Handbrause

W4MB.L/MX

- W4MB.L/BX
- W4MB.L/MB
- W4MB.L/RL
- W4MB.L/BB
- W4MB.L/BC
- W4MB.L/AB
- W4MB.L/DB



W2MBP.L

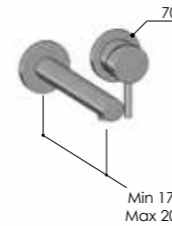

Miscelatore bordo vasca da incasso
Concealed bathtub mixer
Mélangeur pour baignoire encastrable
Monomando empotrado de bañera
UP-Badewannenmischer

Corpo incasso_Concealed body_Corps encastré_Cuerpo empotrado_UP-Teil (pag. 209)

W2MP.INC

Parti esterne_External parts_Parties externes_Parties externas_AP-Teile

W2MBP.L/MX

- W2MBP.L/BX
- W2MBP.L/MB
- W2MBP.L/RL
- W2MBP.L/BB
- W2MBP.L/BC
- W2MBP.L/AB
- W2MBP.L/DB

W3MBP.L

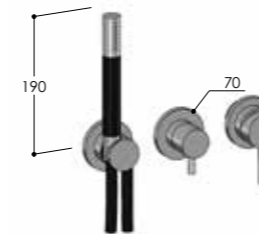

Miscelatore bordo vasca da incasso con doccia
Concealed bathtub mixer with handshower
Mélangeur pour baignoire encastrable avec douche
Monomando empotrado de bañera con teleducha
UP-Badewannenmischer mit Handbrause

Corpo incasso_Concealed body_Corps encastré_Cuerpo empotrado_UP-Teil (pag. 209)

W3MP.INC

Parti esterne_External parts_Parties externes_Parties externas_AP-Teile

W3MBP.L/MX

- W3MBP.L/BX
- W3MBP.L/MB
- W3MBP.L/RL
- W3MBP.L/BB
- W3MBP.L/BC
- W3MBP.L/AB
- W3MBP.L/DB

W4MBP.L

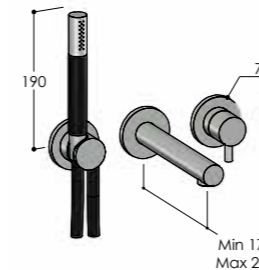

Miscelatore bordo vasca da incasso con doccia
Concealed bathtub mixer with handshower
Mélangeur pour baignoire encastrable avec douche
Monomando empotrado de bañera con teleducha
UP-Badewannenmischer mit Handbrause

Corpo incasso_Concealed body_Corps encastré_Cuerpo empotrado_UP-Teil (pag. 209)

W4MP.INC

Parti esterne_External parts_Parties externes_Parties externas_AP-Teile

W4MBP.L/MX

- W4MBP.L/BX
- W4MBP.L/MB
- W4MBP.L/RL
- W4MBP.L/BB
- W4MBP.L/BC
- W4MBP.L/AB
- W4MBP.L/DB

S40V.RC

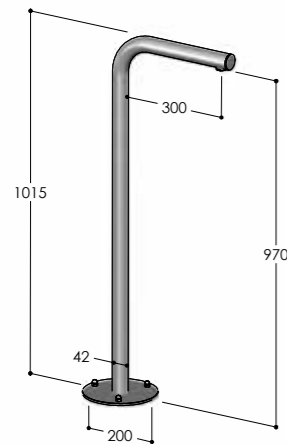

Colonna per vasca per comando remoto
 Bathtub column for remote control
 Colonne pour baignoire pour commande à distance
 Columna de bañera para control remoto
 Badewannensäule für Fernsteuerung

✓	S40V.RC/MX S40V.RC/BX S40V.RC/MB S40V.RC/RL
	Corpo incasso_Concealed body_Corps encastré_Cuerpo empotrado_UP-Teil (pag. 209)
	CW.1
CW	Parti esterne_External parts_Parties externes_Parties externas_AP-Teile S40V.XCW.RC/MX S40V.XCW.RC/BX S40V.XCW.RC/MB S40V.XCW.RC/RL

S40V.M

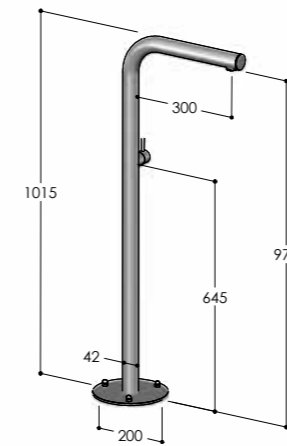

Colonna per vasca con miscelatore
 Bathtub column with mixer
 Colonne pour baignoire avec mitigeur
 Columna de bañera con monomando
 Badewannensäule mit Einhebelmischer

✓	S40V.M/MX S40V.M/BX S40V.M/MB S40V.M/RL
	Corpo incasso_Concealed body_Corps encastré_Cuerpo empotrado_UP-Teil (pag. 209)
	CW.2
CW	Parti esterne_External parts_Parties externes_Parties externas_AP-Teile S40V.XCW.M/MX S40V.XCW.M/BX S40V.XCW.M/MB S40V.XCW.M/RL

S40V

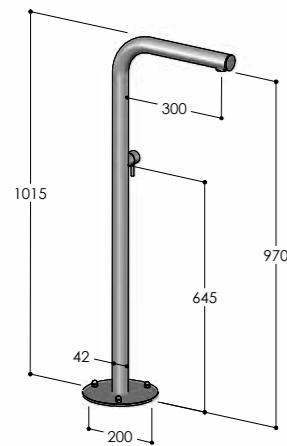

Colonna per vasca con rubinetto d'arresto
 Bathtub column with stop tap
 Colonne pour baignoire avec robinet d'arrêt
 Columna de bañera con grifo
 Badewannensäule mit Wasserhahn

✓	S40V/MX S40V/BX S40V/MB S40V/RL
	Corpo incasso_Concealed body_Corps encastré_Cuerpo empotrado_UP-Teil (pag. 209)
	CW.1
CW	Parti esterne_External parts_Parties externes_Parties externas_AP-Teile S40V.XCW/MX S40V.XCW/BX S40V.XCW/MB S40V.XCW/RL

S40V.ME

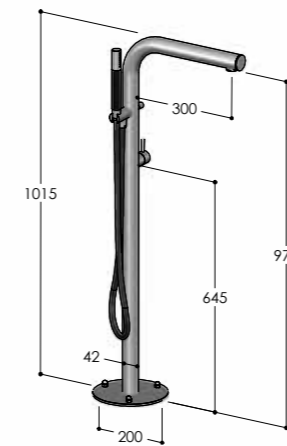

Colonna per vasca con miscelatore e doccia
 Bathtub column with mixer and handshower
 Colonne pour baignoire avec mitigeur et douchette
 Columna de bañera con monomando y teleducha
 Badewannensäule mit Einhebelmischer und Handbrause

✓	S40V.ME/MX S40V.ME/BX S40V.ME/MB S40V.ME/RL
	Corpo incasso_Concealed body_Corps encastré_Cuerpo empotrado_UP-Teil (pag. 209)
	CW.2
CW	Parti esterne_External parts_Parties externes_Parties externas_AP-Teile S40V.XCW.ME/MX S40V.XCW.ME/BX S40V.XCW.ME/MB S40V.XCW.ME/RL

S40V.E

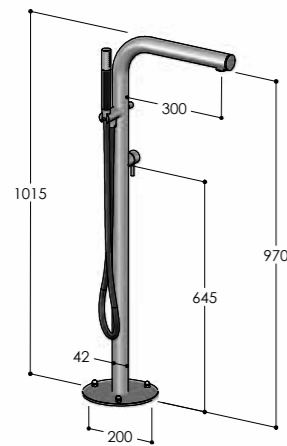

Colonna per vasca con rubinetto d'arresto e doccia
 Bathtub column with stop tap and handshower
 Colonne pour baignoire avec robinet d'arrêt et douchette
 Columna de bañera con grifo y teleducha
 Badewannensäule mit Wasserhahn und Handbrause

✓	S40V.E/MX S40V.E/BX S40V.E/MB S40V.E/RL
	Corpo incasso_Concealed body_Corps encastré_Cuerpo empotrado_UP-Teil (pag. 209)
	CW.1
CW	Parti esterne_External parts_Parties externes_Parties externas_AP-Teile S40V.XCW.E/MX S40V.XCW.E/BX S40V.XCW.E/MB S40V.XCW.E/RL



S60V.HF.M

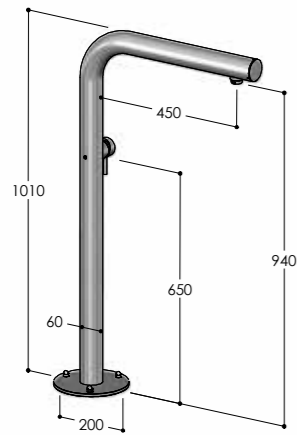

Colonna High-Flow per vasca con miscelatore
High-Flow bathtub column with mixer
Colonne High-Flow pour baignoire avec mitigeur
Column de bañera High-Flow con monomando
High-Flow Badewannensäule mit Einhebelmischer

✓	S60V.HF.M/MX S60V.HF.M/BX S60V.HF.M/MB S60V.HF.M/RL
	Corpo incasso_Concealed body_Corps encastré_Cuerpo empotrado_UP-Teil (pag. 209)
	CW.2
CW	Parti esterne_External parts_Parties externes_Parties externas_AP-Teile S60V.HF.XCW.M/MX S60V.HF.XCW.M/BX S60V.HF.XCW.M/MB S60V.HF.XCW.M/RL
4S	S60V.HF.4S.M/MX S60V.HF.4S.M/BX S60V.HF.4S.M/MB S60V.HF.4S.M/RL

S60V.HF.ME

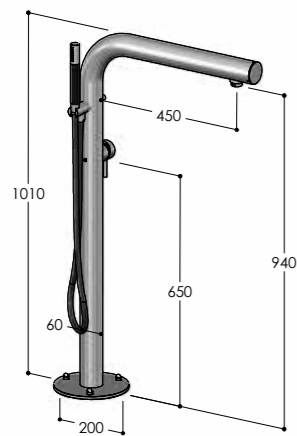

Colonna High-Flow per vasca con miscelatore e doccia
High-Flow bathtub column with mixer and handshower
Colonne High-Flow pour baignoire avec mitigeur et douchette
Column de bañera High-Flow con monomando y teleducha
High-Flow Badewannensäule mit Einhebelmischer und Handbrause

✓	S60V.HF.ME/MX S60V.HF.ME/BX S60V.HF.ME/MB S60V.HF.ME/RL
	Corpo incasso_Concealed body_Corps encastré_Cuerpo empotrado_UP-Teil (pag. 209)
	CW.2
CW	Parti esterne_External parts_Parties externes_Parties externas_AP-Teile S60V.HF.XCW.ME/MX S60V.HF.XCW.ME/BX S60V.HF.XCW.ME/MB S60V.HF.XCW.ME/RL
4S	S60V.HF.4S.ME/MX S60V.HF.4S.ME/BX S60V.HF.4S.ME/MB S60V.HF.4S.ME/RL



ST.L

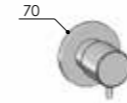

Rubinetto incasso
Concealed tap
Robinet d'arrêt encastrable
Llave de paso
UP-Ventil

	Corpo incasso_Concealed body_Corps encastré_Cuerpo empotrado_UP-Teil (pag. 209)
	ST.INC
	Parti esterne_External parts_Parties externes_Parties externas_AP-Teile
	ST.L/MX ST.L/BX ST.L/MB ST.L/RL ST.L/BB ST.L/BC ST.L/AB ST.L/DB

MR

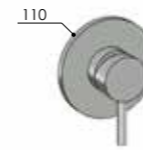

Miscelatore da incasso per doccia
Concealed shower mixer
Mitigeur de douche à encastrer
Monomando de ducha mural
UP-Brausemischer

	Corpo incasso_Concealed body_Corps encastré_Cuerpo empotrado_UP-Teil (pag. 209)
	MR.INC
	Parti esterne_External parts_Parties externes_Parties externas_AP-Teile
	MR/MX MR/BX MR/MB MR/RL MR/BB MR/BC MR/AB MR/DB

MR2.L

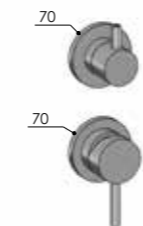

Miscelatore da incasso per doccia, con deviatore a 2 vie
Concealed shower mixer with 2-ways diverter
Mitigeur de douche encastrable avec inverseur à 2 voies
Monomando empotrado para ducha con desviador 2 salidas
UP-Brausemischer mit 2-Wege Umsteller

	Corpo incasso_Concealed body_Corps encastré_Cuerpo empotrado_UP-Teil (pag. 209)
	MR2.INC
	Parti esterne_External parts_Parties externes_Parties externas_AP-Teile
	MR2.L/MX MR2.L/BX MR2.L/MB MR2.L/RL MR2.L/BB MR2.L/BC MR2.L/AB MR2.L/DB

MR3.L

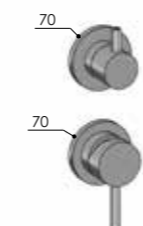

Miscelatore da incasso per doccia, con deviatore a 3 vie
Concealed shower mixer with 3-ways diverter
Mitigeur de douche encastrable avec inverseur à 3 voies
Monomando empotrado para ducha con desviador 3 salidas
UP-Brausemischer mit 3-Wege Umsteller

	Corpo incasso_Concealed body_Corps encastré_Cuerpo empotrado_UP-Teil (pag. 209)
	MR3.INC
	Parti esterne_External parts_Parties externes_Parties externas_AP-Teile
	MR3.L/MX MR3.L/BX MR3.L/MB MR3.L/RL MR3.L/BB MR3.L/BC MR3.L/AB MR3.L/DB

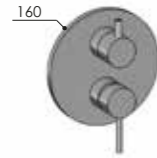

MX2.L



Miscelatore da incasso per doccia, con deviatore a 2 vie
 Concealed shower mixer with 2-ways diverter
 Mitigeur de douche encastrable avec inverseur à 2 voies
 Monomando empotrado para ducha con desviador 2 salidas
 UP-Brausemischer mit 2-Wege Umsteller

Corpo incasso_Concealed body_Corps encastré_Cuerpo empotrado_UP-Teil (pag. 209)

MX.INC

Parti esterne_External parts_Parties externes_Parties externas_AP-Teile

MX2.L/MX

- MX2.L/BX
- MX2.L/MB
- MX2.L/RL
- MX2.L/BB
- MX2.L/BC
- MX2.L/AB
- MX2.L/DB

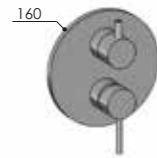

MX3.L



Miscelatore da incasso per doccia, con deviatore a 3 vie
 Concealed shower mixer with 3-ways diverter
 Mitigeur de douche encastrable avec inverseur à 3 voies
 Monomando empotrado para ducha con desviador 3 salidas
 UP-Brausemischer mit 3-Wege Umsteller

Corpo incasso_Concealed body_Corps encastré_Cuerpo empotrado_UP-Teil (pag. 209)

MX.INC

Parti esterne_External parts_Parties externes_Parties externas_AP-Teile

MX3.L/MX

- MX3.L/BX
- MX3.L/MB
- MX3.L/RL
- MX3.L/BB
- MX3.L/BC
- MX3.L/AB
- MX3.L/DB

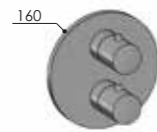

TC1.L



Miscelatore termostatico da incasso per doccia
 Concealed thermostatic mixer for shower
 Mitigeur thermostatique de douche
 Mezclador termostatico empotrado para ducha
 UP-Thermostat-Brausemischer

Corpo incasso_Concealed body_Corps encastré_Cuerpo empotrado_UP-Teil (pag. 209)

MX.INC

Parti esterne_External parts_Parties externes_Parties externas_AP-Teile

TC1.L/MX

- TC1.L/BX
- TC1.L/MB
- TC1.L/RL
- TC1.L/BB
- TC1.L/BC
- TC1.L/AB
- TC1.L/DB

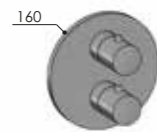

TC2.L



Miscelatore termostatico da incasso per doccia, 2 vie
 Concealed thermostatic mixer for shower, 2-ways
 Mitigeur thermostatique de douche, 2-voies
 Mezclador termostatico empotrado para ducha, 2-salidas
 UP-Thermostat-Brausemischer, 2-Wege

Corpo incasso_Concealed body_Corps encastré_Cuerpo empotrado_UP-Teil (pag. 209)

MX.INC

Parti esterne_External parts_Parties externes_Parties externas_AP-Teile

TC2.L/MX

- TC2.L/BX
- TC2.L/MB
- TC2.L/RL
- TC2.L/BB
- TC2.L/BC
- TC2.L/AB
- TC2.L/DB

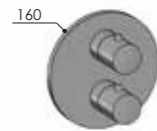

TC3.L



Miscelatore termostatico da incasso per doccia, 3 vie
 Concealed thermostatic mixer for shower, 3-ways
 Mitigeur thermostatique de douche, 3-voies
 Mezclador termostatico empotrado para ducha, 3-salidas
 UP-Thermostat-Brausemischer, 3-Wege

Corpo incasso_Concealed body_Corps encastré_Cuerpo empotrado_UP-Teil (pag. 209)

MX.INC

Parti esterne_External parts_Parties externes_Parties externas_AP-Teile

TC3.L/MX

- TC3.L/BX
- TC3.L/MB
- TC3.L/RL
- TC3.L/BB
- TC3.L/BC
- TC3.L/AB
- TC3.L/DB

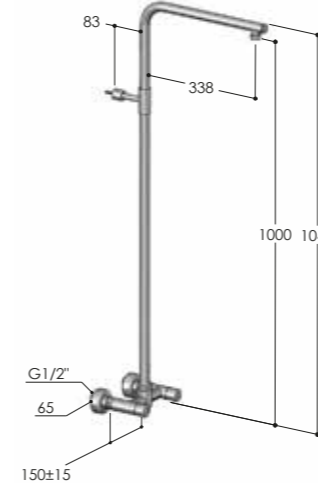

W730



Gruppo esterno con colonna doccia e soffione incassato
 Wall-mounted shower mixer, with column and concealed showerhead
 Mélangeur douche avec colonne et pomme de douche intégrée
 Batería para ducha con columna y rociador integrado
 AP-Brausebatterie mit Stange und integrierter Kopfbrause

W730/MX

- W730/BX
- W730/MB
- W730/RL
- W730/BB
- W730/BC
- W730/AB
- W730/DB

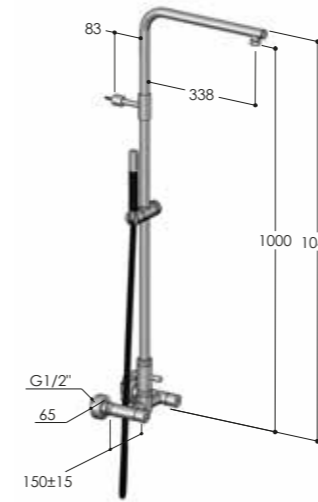

W730.E



Gruppo esterno con colonna doccia, soffione incassato e doccia
 Wall-mounted shower mixer, with column, concealed showerhead and handshower
 Mélangeur douche avec colonne, pomme de douche intégrée et douchette
 Batería para ducha con columna, rociador integrado y teleducha
 AP-Brausebatterie mit Stange, integrierter Kopfbrause und Handbrause

W730.E/MX

- W730.E/BX
- W730.E/MB
- W730.E/RL
- W730.E/BB
- W730.E/BC
- W730.E/AB
- W730.E/DB

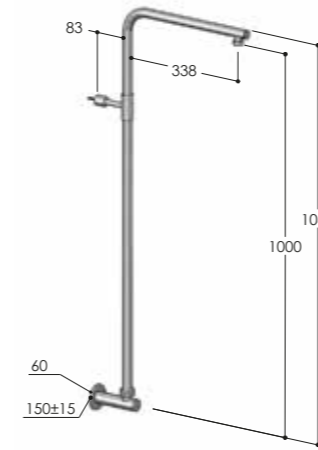

W7X1

Preso d'acqua con colonna doccia e soffione incassato
 Wall coupling, with column and concealed showerhead
 Coude de sortie, avec colonne et pomme de douche intégrée
 Codo mural, con columna y rociador integrado
 Wandanschlußbogen mit Stange und integrierter Kopfbrause

W7X1/MX

- W7X1/BX
- W7X1/MB
- W7X1/RL
- W7X1/BB
- W7X1/BC
- W7X1/AB
- W7X1/DB

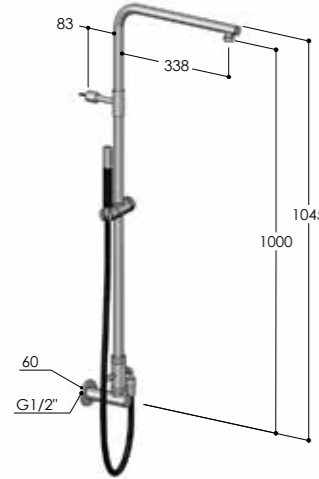

W7X1.E

Presse d'eau avec colonne douche, soufflons encastrés et douchette
 Wall coupling, with column, concealed showerhead and handshower
 Coude de sortie, avec colonne, pomme de douche intégrée et douchette
 Codo mural, con columna, rociador integrado y teleducha
 Wandanschlußbogen mit Stange, integrierter Kopfbräuse und Handbräuse



W7X1.E/MX

- W7X1.E/BX
- W7X1.E/MB
- W7X1.E/RL
- W7X1.E/BB
- W7X1.E/BC
- W7X1.E/AB
- W7X1.E/DB

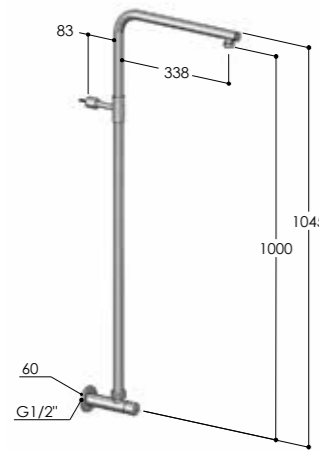

W732

Rubinetto esterno con colonna doccia e soffione incassato
 Wall-mounted tap with column and concealed showerhead
 Robinet mural avec colonne et pomme de douche intégrée
 Grifo mural con columna y rociador integrado
 AP-Ventil mit Stange und integrierter Kopfbräuse



W732/MX

- W732/BX
- W732/MB
- W732/RL
- W732/BB
- W732/BC
- W732/AB
- W732/DB

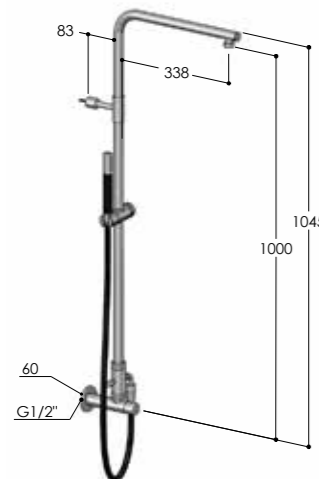

W732.E

Rubinetto esterno con colonna doccia, soffione incassato e douchette
 Wall-mounted tap with column, concealed showerhead and handshower
 Robinet mural avec colonne, pomme de douche intégrée et douchette
 Grifo mural con columna, rociador integrado y teleducha
 AP-Ventil mit Stange, integrierter Kopfbräuse und Handbräuse



W732.E/MX

- W732.E/BX
- W732.E/MB
- W732.E/RL
- W732.E/BB
- W732.E/BC
- W732.E/AB
- W732.E/DB



W783

Miscelatore esterno con colonna doccia e soffione incassato
 Wall-mounted mixer, with column and concealed showerhead
 Mitigeur mural avec colonne et pomme de douche intégrée
 Mezclador mural con columna y rociador integrado
 AP-Brausemischer mit Stange und integrierter Kopfbräuse



W783/MX

- W783/BX
- W783/MB
- W783/RL
- W783/BB
- W783/BC
- W783/AB
- W783/DB

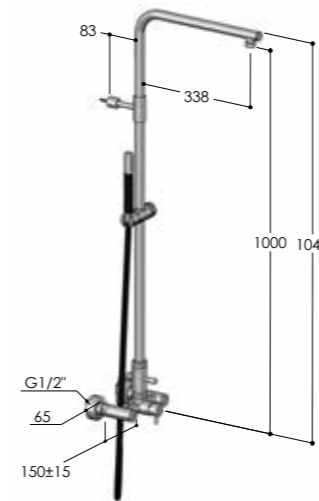

W783.E

Miscelatore esterno con colonna doccia, soffione incassato e douchette
 Wall-mounted mixer, with column, concealed showerhead and handshower
 Mitigeur mural avec colonne, pomme de douche intégrée et douchette
 Mezclador mural con columna, rociador integrado y teleducha
 AP-Brausemischer mit Stange, integrierter Kopfbräuse und Handbräuse



W783.E/MX

- W783.E/BX
- W783.E/MB
- W783.E/RL
- W783.E/BB
- W783.E/BC
- W783.E/AB
- W783.E/DB

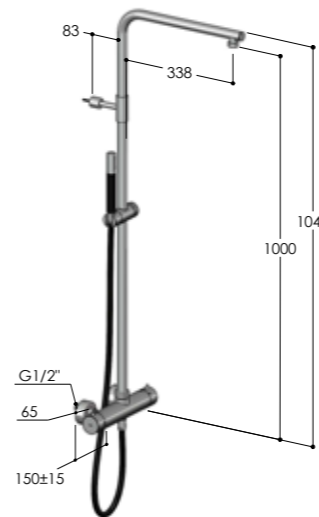

W775.E

Miscelatore termostatico esterno con colonna doccia, soffione incassato e douchette
 Wall-mounted thermostatic mixer, with column, concealed showerhead and handshower
 Mitigeur thermostatique mural avec colonne, pomme de douche intégrée et douchette
 Mezclador termostático mural con columna, rociador integrado y teleducha
 AP-Thermostat-Brausemischer mit Stange, integrierter Kopfbräuse und Handbräuse



W775.E/MX

- W775.E/BX
- W775.E/MB
- W775.E/RL
- W775.E/BB
- W775.E/BC
- W775.E/AB
- W775.E/DB

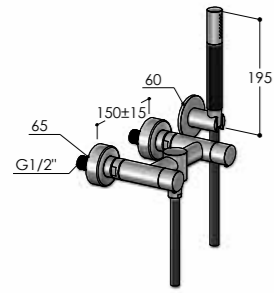

WX30.SK

Gruppo esterno con kit doccia
Wall-mounted mixer with shower kit
Mélangeur mural avec kit de douche
Bateria con kit de ducha mural
AP-Batterie mit Brausekit

WX30.SK/MX

- WX30.SK/BX
- WX30.SK/MB
- WX30.SK/RL
- WX30.SK/BB
- WX30.SK/BC
- WX30.SK/AB
- WX30.SK/DB

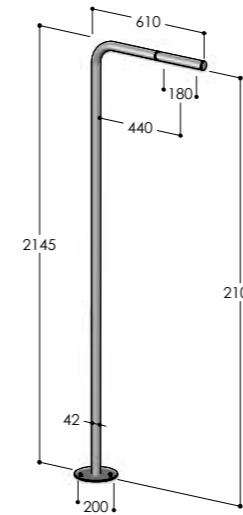

S40.RC

Colonna doccia con soffione incassato per comando remoto
Shower column with concealed showerhead for remote control
Colonne douche avec pomme de douche intégrée pour commande à distance
Column de ducha con rociador integrado para control remoto
Duschsäule mit integrierter Kopfbrause für Fernsteuerung

S40.RC/MX

- S40.RC/BX
- S40.RC/MB
- S40.RC/RL
- Corpo incasso_Concealed body_Corps encastré_Cuerpo empotrado_UP-Teil (pag. 209)
- CW.1**
- Parti externe_External parts_Parties externes_Parties externas_AP-Teile
- S40.XCW.RC/MX**
- S40.XCW.RC/BX
- S40.XCW.RC/MB
- S40.XCW.RC/RL
- S40.EW.RC/MX**
- S40.EW.RC/BX
- S40.EW.RC/MB
- S40.EW.RC/RL

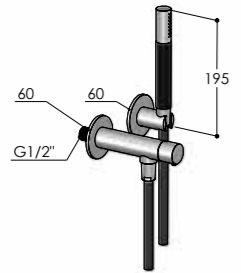

WX32.SK

Rubinetto esterno con kit doccia
Wall-mounted tap with shower kit
Robinet mural avec kit de douche
Grifo mural con kit de ducha
AP-Ventil, mit Brausekit

WX32.SK/MX

- WX32.SK/BX
- WX32.SK/MB
- WX32.SK/RL
- WX32.SK/BB
- WX32.SK/BC
- WX32.SK/AB
- WX32.SK/DB

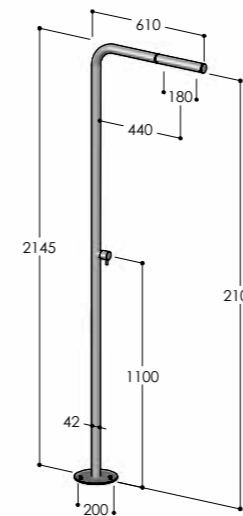

S40

Colonna doccia con rubinetto d'arresto e soffione incassato
Shower column with stop tap and concealed showerhead
Colonne douche avec robinet d'arrêt et pomme de douche intégrée
Column de ducha con grifo y rociador integrado
Duschsäule mit Wasserhahn und integrierter Kopfbrause

S40/MX

- S40/BX
- S40/MB
- S40/RL
- Corpo incasso_Concealed body_Corps encastré_Cuerpo empotrado_UP-Teil (pag. 209)
- CW.1**
- Parti externe_External parts_Parties externes_Parties externas_AP-Teile
- S40.XCW/MX**
- S40.XCW/BX
- S40.XCW/MB
- S40.XCW/RL
- S40.EW/MX**
- S40.EW/BX
- S40.EW/MB
- S40.EW/RL

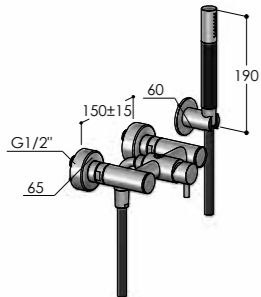

WX83.SK

Miscelatore esterno con kit doccia
Wall-mounted mixer with shower kit
Mitigeur mural avec kit de douche
Mezclador mural con kit de ducha
AP-Brausemischer mit Brausekit

WX83.SK/MX

- WX83.SK/BX
- WX83.SK/MB
- WX83.SK/RL
- WX83.SK/BB
- WX83.SK/BC
- WX83.SK/AB
- WX83.SK/DB

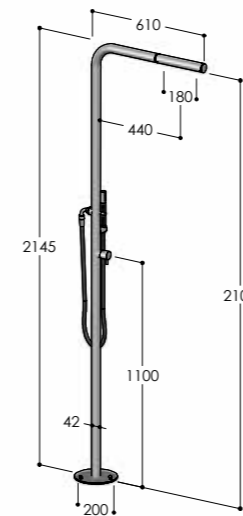

S40.E

Colonna doccia con rubinetto d'arresto, soffione incassato e doccia
Shower column with stop tap, concealed showerhead and handshower
Colonne douche avec robinet d'arrêt, pomme de douche intégrée et douchette
Column de ducha con grifo, rociador integrado y teleducha
Duschsäule mit Wasserhahn, integrierter Kopfbrause und Handbrause

S40.E/MX

- S40.E/BX
- S40.E/MB
- S40.E/RL
- Corpo incasso_Concealed body_Corps encastré_Cuerpo empotrado_UP-Teil (pag. 209)
- CW.1**
- Parti externe_External parts_Parties externes_Parties externas_AP-Teile
- S40.XCW.E/MX**
- S40.XCW.E/BX
- S40.XCW.E/MB
- S40.XCW.E/RL
- S40.EW.E/MX**
- S40.EW.E/BX
- S40.EW.E/MB
- S40.EW.E/RL

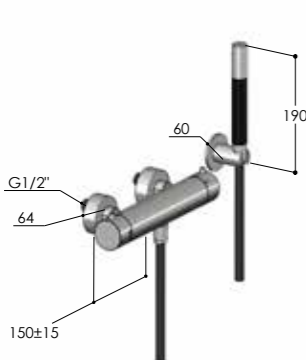

WX75.SK

Miscelatore termostatico esterno con kit doccia
Wall-mounted thermostatic mixer with shower kit
Mitigeur thermostatique mural avec kit de douche
Mezclador termostatico mural con kit de ducha
AP-Thermostat-Brausemischer mit Brausekit

WX75.SK/MX

- WX75.SK/BX
- WX75.SK/MB
- WX75.SK/RL
- WX75.SK/BB
- WX75.SK/BC
- WX75.SK/AB
- WX75.SK/DB

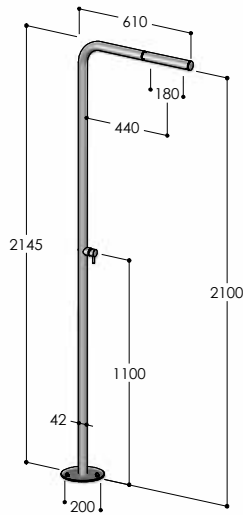

S40.M



Colonna doccia con miscelatore e soffione incassato

Shower column with mixer and concealed showerhead

Colonne douche avec mitigeur et pomme de douche intégrée

Column de ducha con monomando y rociador integrado

Duschsäule mit Einhebelmischer und integrierter Kopfbrause

✓	S40.M/MX
	S40.M/BX
	S40.M/MB
CW	S40.M/RL
	Corpo incasso_Concealed body_Corps encastré_Cuerpo empotrado_UP-Teil (pag. 209)
	CW.1
	Parti esterne_External parts_Parties externes_Parties externas_AP-Teile
	S40.XCW.M/MX
EW	S40.XCW.M/BX
	S40.XCW.M/MB
	S40.XCW.M/RL
EW	S40.EW.M/MX
	S40.EW.M/BX
	S40.EW.M/MB
	S40.EW.M/RL

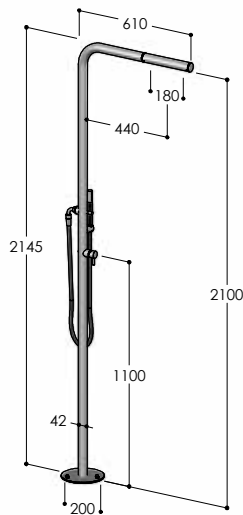

S40.ME



Colonna doccia con miscelatore, soffione incassato e doccia

Shower column with mixer, concealed showerhead and handshower

Colonne douche avec mitigeur, pomme de douche intégrée et douchette

Column de ducha con monomando, rociador integrado y teleducha

Duschsäule mit Einhebelmischer, integrierter Kopfbrause und Handbrause

✓	S40.ME/MX
	S40.ME/BX
	S40.ME/MB
CW	S40.ME/RL
	Corpo incasso_Concealed body_Corps encastré_Cuerpo empotrado_UP-Teil (pag. 209)
	CW.1
	Parti esterne_External parts_Parties externes_Parties externas_AP-Teile
	S40.XCW.ME/MX
EW	S40.XCW.ME/BX
	S40.XCW.ME/MB
	S40.XCW.ME/RL
EW	S40.MEW.ME/MX
	S40.MEW.ME/BX
	S40.MEW.ME/MB
	S40.MEW.ME/RL

CLASSY

Shower

pag. 44



CLASSY

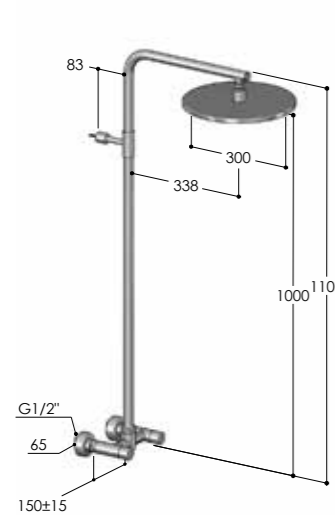

W630

Gruppo esterno con colonna doccia e soffione S10
 Wall-mounted shower mixer, with column and showerhead S10
 Mélangeur douche avec colonne et pomme de douche S10
 Batería para ducha con columna y rociador S10
 AP-Brausebatterie mit Stange und Kopfbrause S10

W630/MX

- W630/BX
- W630/MB
- W630/RL
- W630/BB
- W630/BC
- W630/AB
- W630/DB

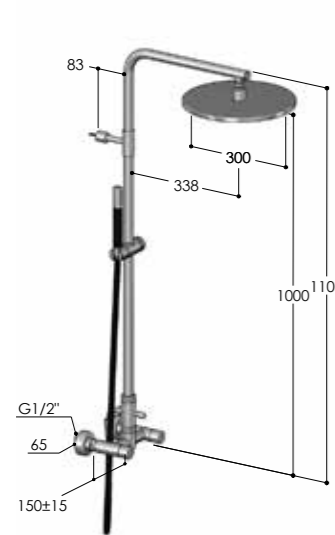

W630.E

Gruppo esterno con colonna doccia, soffione S10 e doccetta
 Wall-mounted shower mixer, with column, showerhead S10 and handshower
 Mélangeur douche avec colonne, pomme de douche S10 et douchette
 Batería para ducha con columna, rociador S10 y teleducha
 AP-Brausebatterie mit Stange, Kopfbrause S10 und Handbrause

W630.E/MX

- W630.E/BX
- W630.E/MB
- W630.E/RL
- W630.E/BB
- W630.E/BC
- W630.E/AB
- W630.E/DB

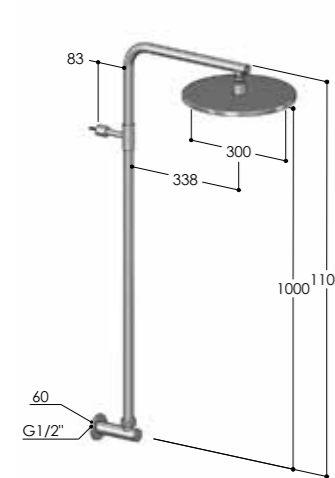

W6X1

Preso d'acqua con colonna doccia e soffione S10
 Wall coupling, with column and showerhead S10
 Coude de sortie, avec colonne et pomme de douche S10
 Codo mural, con columna y rociador S10
 Wandanschlußbogen mit Stange und Kopfbrause S10

W6X1/MX

- W6X1/BX
- W6X1/MB
- W6X1/RL
- W6X1/BB
- W6X1/BC
- W6X1/AB
- W6X1/DB

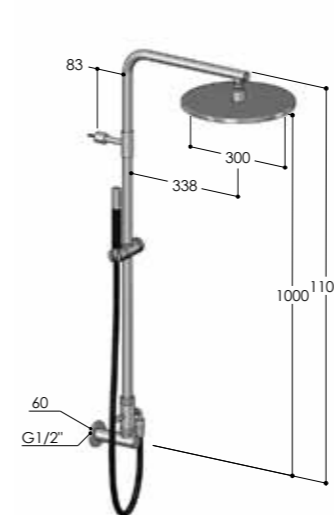

W6X1.E

Preso d'acqua con colonna doccia, soffione S10 e doccetta
 Wall coupling, with column, showerhead S10 and handshower
 Coude de sortie, avec colonne, pomme de douche S10 et douchette
 Codo mural, con columna, rociador S10 y teleducha
 Wandanschlußbogen mit Stange, Kopfbrause S10 und Handbrause

W6X1.E/MX

- W6X1.E/BX
- W6X1.E/MB
- W6X1.E/RL
- W6X1.E/BB
- W6X1.E/BC
- W6X1.E/AB
- W6X1.E/DB

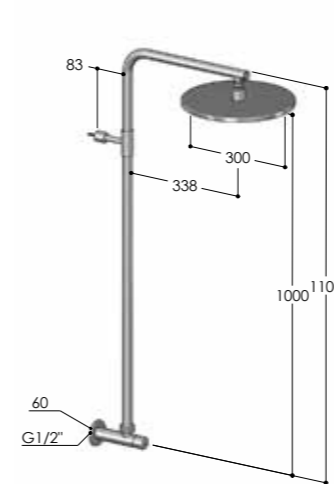

W632

Rubinetto esterno con colonna doccia e soffione S10
 Wall-mounted tap with column and showerhead S10
 Robinet mural avec colonne et pomme de douche S10
 Grifo mural con columna y rociador S10
 AP-Ventil mit Stange und Kopfbrause S10

W632/MX

- W632/BX
- W632/MB
- W632/RL
- W632/BB
- W632/BC
- W632/AB
- W632/DB

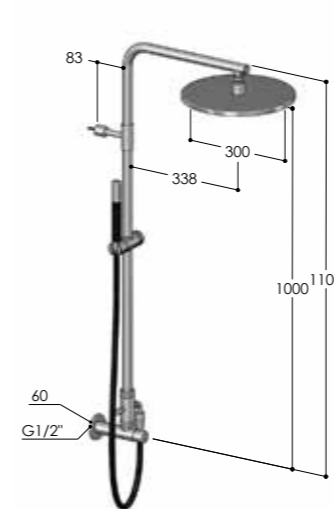

W632.E

Rubinetto esterno con colonna doccia, soffione S10 e doccetta
 Wall-mounted tap with column, showerhead S10 and handshower
 Robinet mural avec colonne, pomme de douche S10 et douchette
 Grifo mural con columna, rociador S10 y teleducha
 AP-Ventil mit Stange, Kopfbrause S10 und Handbrause

W632.E/MX

- W632.E/BX
- W632.E/MB
- W632.E/RL
- W632.E/BB
- W632.E/BC
- W632.E/AB
- W632.E/DB

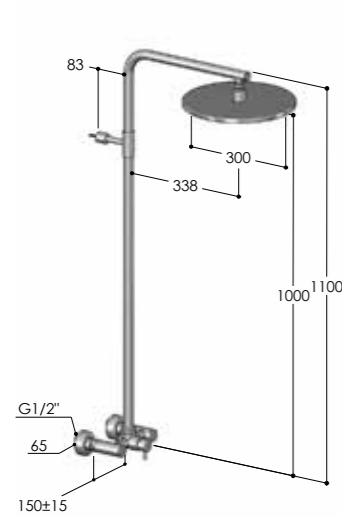

W683

Miscelatore esterno con colonna doccia e soffione S10
 Wall-mounted mixer, with column and showerhead S10
 Mitigeur mural avec colonne et pomme de douche S10
 Mezclador mural con columna y rociador S10
 AP-Brausemischer mit Stange und Kopfbrause S10

W683/MX

- W683/BX
- W683/MB
- W683/RL
- W683/BB
- W683/BC
- W683/AB
- W683/DB

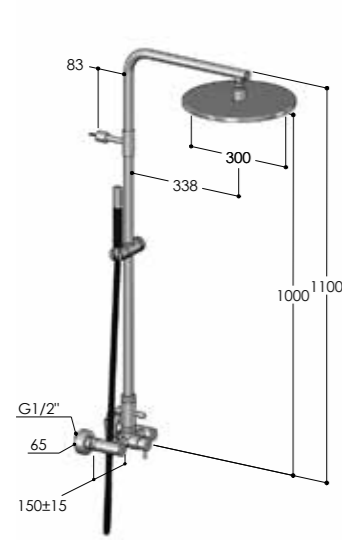

W683.E

Miscelatore esterno con colonna doccia, soffione S10 e doccia
 Wall-mounted mixer, with column, showerhead S10 and handshower
 Mitigeur mural avec colonne, pomme de douche S10 et douchette
 Mezclador mural con columna, rociador S10 y teleducha
 AP-Brausemischer mit Stange, Kopfbrause S10 und Handbrause

W683.E/MX

- W683.E/BX
- W683.E/MB
- W683.E/RL
- W683.E/BB
- W683.E/BC
- W683.E/AB
- W683.E/DB

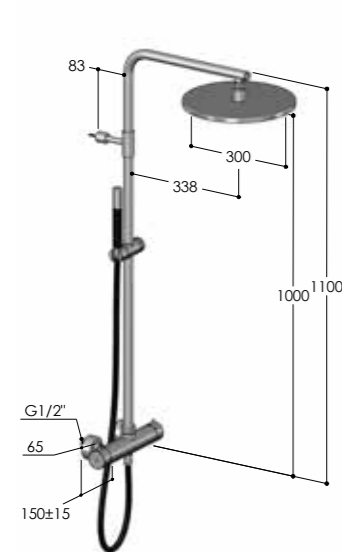

W675.E

Miscelatore termostatico esterno con colonna doccia, soffione S10 e doccia
 Wall-mounted thermostatic mixer, with column, showerhead S10 and handshower
 Mitigeur thermostatique mural avec colonne, pomme de douche S10 et douchette
 Mezclador termostatico mural con columna, rociador S10 y teleducha
 AP-Thermostat-Brausemischer mit Stange, Kopfbrause S10 und Handbrause

W665.E/MX

- W665.E/BX
- W665.E/MB
- W665.E/RL
- W665.E/BB
- W665.E/BC
- W665.E/AB
- W665.E/DB

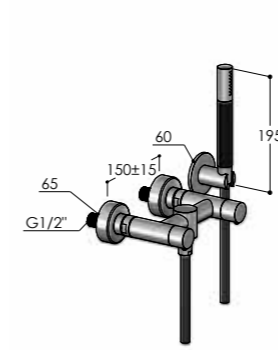

WX30.SK

Gruppo esterno con kit doccia
 Wall-mounted mixer with shower kit
 Mélangeur mural avec kit de douche
 Bateria con kit de ducha mural
 AP-Batterie mit Brausekit

WX30.SK/MX

- WX30.SK/BX
- WX30.SK/MB
- WX30.SK/RL
- WX30.SK/BB
- WX30.SK/BC
- WX30.SK/AB
- WX30.SK/DB

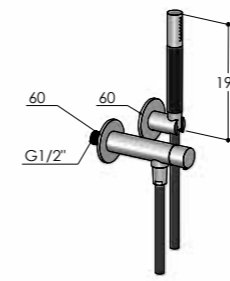

WX32.SK

Rubinetto esterno con kit doccia
 Wall-mounted tap with shower kit
 Robinet mural avec kit de douche
 Grifo mural con kit de ducha
 AP-Ventil, mit Brausekit

WX32.SK/MX

- WX32.SK/BX
- WX32.SK/MB
- WX32.SK/RL
- WX32.SK/BB
- WX32.SK/BC
- WX32.SK/AB
- WX32.SK/DB

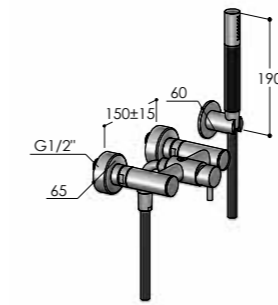

WX83.SK

Miscelatore esterno con kit doccia
 Wall-mounted mixer with shower kit
 Mitigeur mural avec kit de douche
 Mezclador mural con kit de ducha
 AP-Brausemischer mit Brausekit

WX83.SK/MX

- WX83.SK/BX
- WX83.SK/MB
- WX83.SK/RL
- WX83.SK/BB
- WX83.SK/BC
- WX83.SK/AB
- WX83.SK/DB

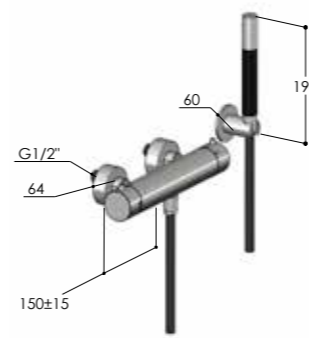

WX75.SK

Miscelatore termostatico esterno con kit doccia
 Wall-mounted thermostatic mixer with shower kit
 Mitigeur thermostatique mural avec kit de douche
 Mezclador termostatico mural con kit de ducha
 AP-Thermostat-Brausemischer mit Brausekit

WX75.SK/MX

- WX75.SK/BX
- WX75.SK/MB
- WX75.SK/RL
- WX75.SK/BB
- WX75.SK/BC
- WX75.SK/AB
- WX75.SK/DB

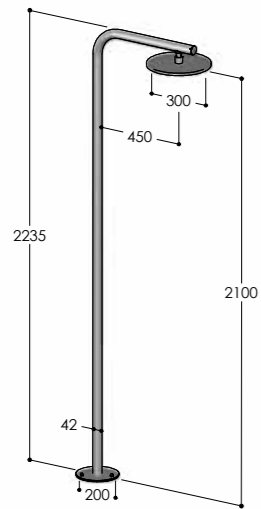

C40.RC

Colonna doccia con soffione S10 per comando remoto
 Shower column with S10 showerhead for remote control
 Colonne douche avec pomme de douche S10 pour commande à distance
 Columna de ducha con rociador S10 para control remoto
 Duschsäule mit Kopfbrause S10 für Fernsteuerung

✓	C40.RC/MX C40.RC/BX C40.RC/MB C40.RC/RL
	Corpo incasso_Concealed body_Corps encastré_Cuerpo empotrado_UP-Teil (pag. 209)
	CW.1
CW	Parti esterne_External parts_Parties externes_Parties externas_AP-Teile C40.XCW.RC/MX C40.XCW.RC/BX C40.XCW.RC/MB C40.XCW.RC/RL
EW	C40.EW.RC/MX C40.EW.RC/BX C40.EW.RC/MB C40.EW.RC/RL

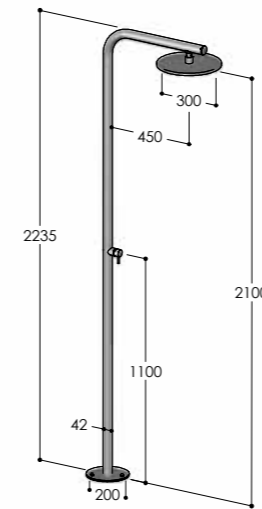

C40.M

Colonna doccia con miscelatore e soffione S10
 Shower column with mixer and showerhead S10
 Colonne douche avec mitigeur et pomme de douche S10
 Columna de ducha con monomando y rociador S10
 Duschsäule mit Einhebelmischer und Kopfbrause S10

✓	C40.M/MX C40.M/BX C40.M/MB C40.M/RL
	Corpo incasso_Concealed body_Corps encastré_Cuerpo empotrado_UP-Teil (pag. 209)
	CW.1
CW	Parti esterne_External parts_Parties externes_Parties externas_AP-Teile C40.XCW.M/MX C40.XCW.M/BX C40.XCW.M/MB C40.XCW.M/RL
EW	C40.EW.M/MX C40.EW.M/BX C40.EW.M/MB C40.EW.M/RL

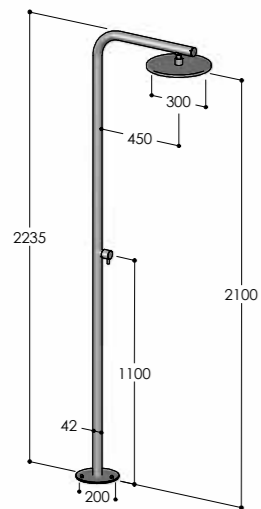

C40

Colonna doccia con rubinetto d'arresto e soffione S10
 Shower column with stop tap and S10 showerhead
 Colonne douche avec robinet d'arrêt et pomme de douche S10
 Columna de ducha con grifo y rociador S10
 Duschsäule mit Wasserhahn und Kopfbrause S10

✓	C40/MX C40/BX C40/MB C40/RL
	Corpo incasso_Concealed body_Corps encastré_Cuerpo empotrado_UP-Teil (pag. 209)
	CW.1
CW	Parti esterne_External parts_Parties externes_Parties externas_AP-Teile C40.XCW/MX C40.XCW/BX C40.XCW/MB C40.XCW/RL
EW	C40.EW/MX C40.EW/BX C40.EW/MB C40.EW/RL

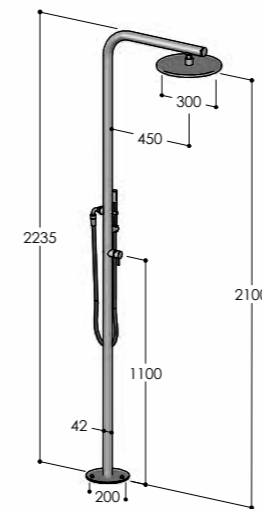

C40.ME

Colonna doccia con miscelatore, soffione S10 e doccia
 Shower column with mixer, showerhead S10 and handshower
 Colonne douche avec mitigeur, pomme de douche S10 et douchette
 Columna de ducha con monomando, rociador S10 y teleducha
 Duschsäule mit Einhebelmischer, Kopfbrause S10 und Handbrause

✓	C40.ME/MX C40.ME/BX C40.ME/MB C40.ME/RL
	Corpo incasso_Concealed body_Corps encastré_Cuerpo empotrado_UP-Teil (pag. 209)
	CW.1
CW	Parti esterne_External parts_Parties externes_Parties externas_AP-Teile C40.XCW.ME/MX C40.XCW.ME/BX C40.XCW.ME/MB C40.XCW.ME/RL
EW	C40.EW.ME/MX C40.EW.ME/BX C40.EW.ME/MB C40.EW.ME/RL

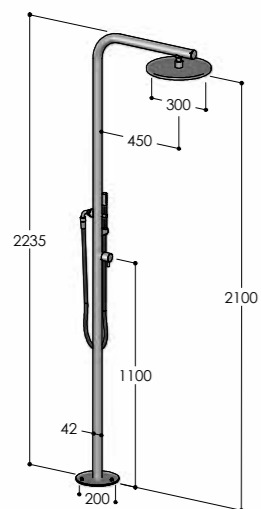

C40.E

Colonna doccia con rubinetto d'arresto, soffione S10 e doccia
 Shower column with stop tap, S10 showerhead and handshower
 Colonne douche avec robinet d'arrêt, pomme de douche S10 et douchette
 Columna de ducha con grifo, rociador S10 y teleducha
 Duschsäule mit Wasserhahn, Kopfbrause S10 und Handbrause

✓	C40.E/MX C40.E/BX C40.E/MB C40.E/RL
	Corpo incasso_Concealed body_Corps encastré_Cuerpo empotrado_UP-Teil (pag. 209)
	CW.1
CW	Parti esterne_External parts_Parties externes_Parties externas_AP-Teile C40.XCW.E/MX C40.XCW.E/BX C40.XCW.E/MB C40.XCW.E/RL
EW	C40.EW.E/MX C40.EW.E/BX C40.EW.E/MB C40.EW.E/RL



TWIGGY

Basin	<i>pag. 52</i>
Bathtub	<i>pag. 56</i>
Shower	<i>pag. 61</i>



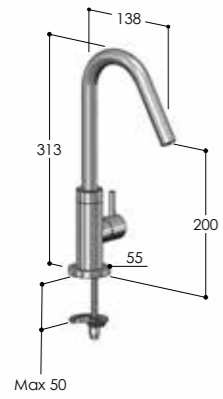

W30 
 Miscelatore da lavabo
 Washbasin mixer
 Mitigeur de lavabo
 Monomando de lavabo
 Waschtischmischer

- W30/MX**
 W30/BX
 W30/MB
 W30/RL
 W30/BB
 W30/BC
 W30/AB
 W30/DB

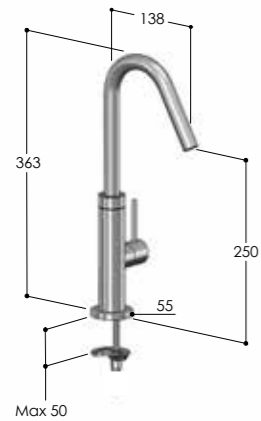

W30H 
 Miscelatore alto da lavabo
 Washbasin pillar mixer
 Mitigeur haut de lavabo
 Monomando de lavabo alto
 Waschtischmischer hoch

- W30H/MX**
 W30H/BX
 W30H/MB
 W30H/RL
 W30H/BB
 W30H/BC
 W30H/AB
 W30H/DB



W30B 
 Miscelatore da bidet
 Bidet mixer
 Mitigeur de bidet
 Monomando de bidet
 Bidetmischer

- W30B/MX**
 W30B/BX
 W30B/MB
 W30B/RL
 W30B/BB
 W30B/BC
 W30B/AB
 W30B/DB



W3.Y 
 Batteria da lavabo 3 fori
 Basin set 3-holes
 Mélangeur de lavabo 3 trous
 Batería para lavabo 3 agujeros
 3-Loch Waschtischbatterie

- W3.Y/MX**
 W3.Y/BX
 W3.Y/MB
 W3.Y/RL
 W3.Y/BB
 W3.Y/BC
 W3.Y/AB
 W3.Y/DB

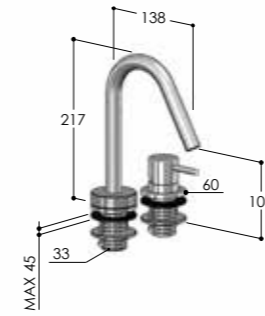

W2M.Y 
 Miscelatore da bordo lavabo
 Deck-mounted washbasin mixer
 Mitigeur de lavabo, montage sur gorge
 Monomando para borde de lavabo
 Waschtisch-Batterie für Randmontage

- W2M.Y/MX**
 W2M.Y/BX
 W2M.Y/MB
 W2M.Y/RL
 W2M.Y/BB
 W2M.Y/BC
 W2M.Y/AB
 W2M.Y/DB

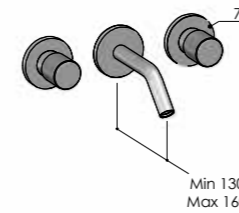

W3P.Y 
 Batteria lavabo da incasso
 Concealed washbasin set
 Mélangeur lavabo à encastrer
 Batería mural de lavabo
 Wandmontierte-Waschtisch-Batterie

- Corpo incasso_Concealed body_Corps encastré_Cuerpo empotrado_UP-Teil (pag. 209)
W3P.INC
 Parti esterne_External parts_Parties externes_Parties externas_AP-Teile
W3P.Y/MX
 W3P.Y/BX
 W3P.Y/MB
 W3P.Y/RL
 W3P.Y/BB
 W3P.Y/BC
 W3P.Y/AB
 W3P.Y/DB

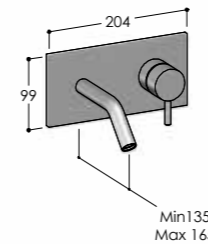

W2MP.Y 
 Miscelatore lavabo da incasso
 Concealed washbasin mixer
 Mitigeur lavabo à encastrer
 Monomando mural de lavabo
 UP-Waschtisch-Einhandbatterie

- Corpo incasso_Concealed body_Corps encastré_Cuerpo empotrado_UP-Teil (pag. 209)
W2MP.INC
 Parti esterne_External parts_Parties externes_Parties externas_AP-Teile
W2MP.Y/MX
 W2MP.Y/BX
 W2MP.Y/MB
 W2MP.Y/RL
 W2MP.Y/BB
 W2MP.Y/BC
 W2MP.Y/AB
 W2MP.Y/DB

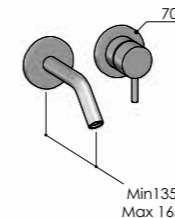

W2MP.2.Y 
 Miscelatore lavabo da incasso
 Concealed washbasin mixer
 Mitigeur lavabo à encastrer
 Monomando mural de lavabo
 UP-Waschtisch-Einhandbatterie

- Corpo incasso_Concealed body_Corps encastré_Cuerpo empotrado_UP-Teil (pag. 209)
W2MP.INC
 Parti esterne_External parts_Parties externes_Parties externas_AP-Teile
W2MP.2.Y/MX
 W2MP.2.Y/BX
 W2MP.2.Y/MB
 W2MP.2.Y/RL
 W2MP.2.Y/BB
 W2MP.2.Y/BC
 W2MP.2.Y/AB
 W2MP.2.Y/DB



WMRL



Miscelatore da incasso per lavabo
 Concealed mixer for washbasin
 Mitiguer encastrable pour lavabo
 Monomando empotrado para lavabo
 Waschtischmischer

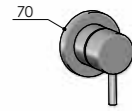

Corpo incasso_Concealed body_Corps encastré_Cuerpo empotrado_UP-Teil (pag. 209)

MR.INC

Parti esterne_External parts_Parties externes_Parties externas_AP-Teile

WMRL/MX

- WMRL/BX
- WMRL/MB
- WMRL/RL
- WMRL/BB
- WMRL/BC
- WMRL/AB
- WMRL/DB

SP.Y

Bocca a parete
 Wall-mounted spout
 Bec déverseur
 Caño mural
 Wandmontierter Wanneneinlauf

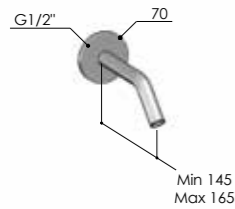

SP.Y/MX

- SP.Y/BX
- SP.Y/MB
- SP.Y/RL
- SP.Y/BB
- SP.Y/BC
- SP.Y/AB
- SP.Y/DB



CS40L.RC

Colonna per lavabo per comando remoto
 Washbasin column for remote control
 Colonne pour lavabo pour commande à distance
 Column de lavabo para control remoto
 Waschtischsäule für Fernsteuerung

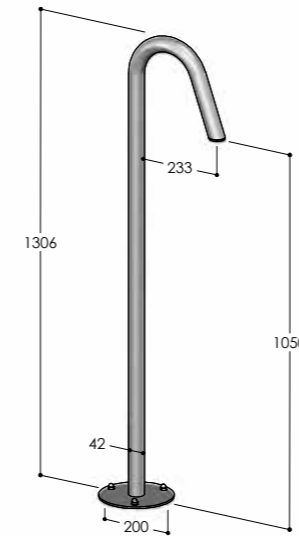

CS40L.RC/MX

- CS40L.RC/BX
- CS40L.RC/MB
- CS40L.RC/RL

Corpo incasso_Concealed body_Corps encastré_Cuerpo empotrado_UP-Teil (pag. 209)

CW.1

Parti esterne_External parts_Parties externes_Parties externas_AP-Teile

CW

- CS40L.XCW.RC/MX**
- CS40L.XCW.RC/BX
- CS40L.XCW.RC/MB
- CS40L.XCW.RC/RL

CS40L

Colonna per lavabo con rubinetto d'arresto
 Washbasin column with stop tap
 Colonne pour lavabo avec robinet d'arrêt
 Column de lavabo con grifo
 Waschtischsäule mit Wasserhahn

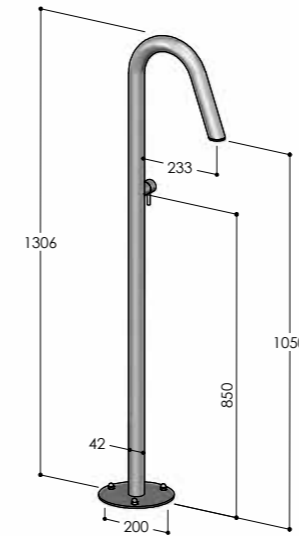

CS40L/MX

- CS40L/BX
- CS40L/MB
- CS40L/RL

Corpo incasso_Concealed body_Corps encastré_Cuerpo empotrado_UP-Teil (pag. 209)

CW.1

Parti esterne_External parts_Parties externes_Parties externas_AP-Teile

CW

- CS40L.XCW/MX**
- CS40L.XCW/BX
- CS40L.XCW/MB
- CS40L.XCW/RL

CS40L.M



Colonna per lavabo con miscelatore
 Washbasin column with mixer
 Colonne pour lavabo avec mitigueur
 Column de lavabo con monomando
 Waschtischsäule mit Einhebelmischer

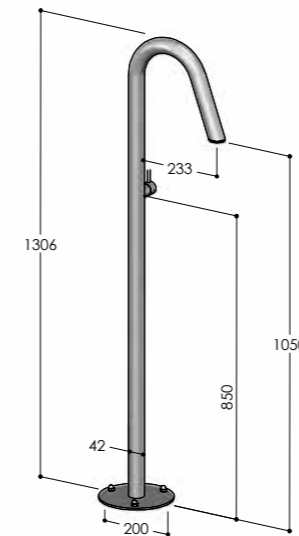

CS40L.M/MX

- CS40L.M/BX
- CS40L.M/MB
- CS40L.M/RL

Corpo incasso_Concealed body_Corps encastré_Cuerpo empotrado_UP-Teil (pag. 209)

CW.2

Parti esterne_External parts_Parties externes_Parties externas_AP-Teile

CW

- CS40L.XCW.M/MX**
- CS40L.XCW.M/BX
- CS40L.XCW.M/MB
- CS40L.XCW.M/RL



W3B.Y

Batteria bordo vasca 3 fori
Bathtub set 3-holes
Mélangeur de baignoire pour montage sur gorge, 5 trous
Bateria para borde de bañera, 3 agujeros
3-Loch Badewannenbatterie für Randmontage

W3B.Y/MX

- W3B.Y/BX
- W3B.Y/MB
- W3B.Y/RL
- W3B.Y/BB
- W3B.Y/BC
- W3B.Y/AB
- W3B.Y/DB



W5B.Y

Batteria bordo vasca 5 fori
Bathtub set 5-holes
Mélangeur de baignoire pour montage sur gorge, 5 trous
Bateria para borde de bañera, 5 agujeros
5-Loch Badewannenbatterie für Randmontage

W5B.Y/MX

- W5B.Y/BX
- W5B.Y/MB
- W5B.Y/RL
- W5B.Y/BB
- W5B.Y/BC
- W5B.Y/AB
- W5B.Y/DB



W2MB.Y

Miscelatore per bordo vasca
Deck-mounted bathtub mixer
Mitigeur de baignoire pour montage sur gorge
Monomando de repisa para bañera
Badewannenmischer für Randmontage

W2MB.Y/MX

- W2MB.Y/BX
- W2MB.Y/MB
- W2MB.Y/RL
- W2MB.Y/BB
- W2MB.Y/BC
- W2MB.Y/AB
- W2MB.Y/DB

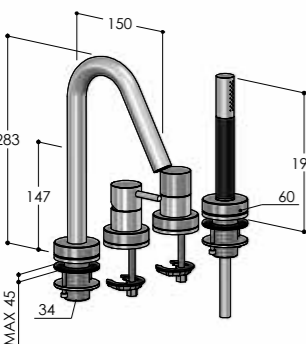

W4MB.Y

Miscelatore per bordo vasca con doccia
Deck-mounted bathtub mixer with handshower
Mitigeur de baignoire pour montage sur gorge avec douche
Monomando de repisa para bañera con teleducha
Badewannenmischer für Randmontage mit Handbrause

W4MB.Y/MX

- W4MB.Y/BX
- W4MB.Y/MB
- W4MB.Y/RL
- W4MB.Y/BB
- W4MB.Y/BC
- W4MB.Y/AB
- W4MB.Y/DB

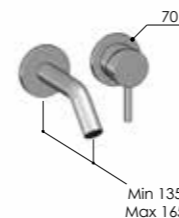

W2MBP.Y

Miscelatore bordo vasca da incasso
Concealed bathtub mixer
Mélangeur pour baignoire encastrable
Monomando empotrado de bañera
UP-Badewannenmischer

Corpo incasso_Concealed body_Corps encastré_Cuerpo empotrado_UP-Teil (pag. 209)

W2MP.INC

Parti esterne_External parts_Parties externes_Parties externas_AP-Teile

W2MBP.Y/MX

- W2MBP.Y/BX
- W2MBP.Y/MB
- W2MBP.Y/RL
- W2MBP.Y/BB
- W2MBP.Y/BC
- W2MBP.Y/AB
- W2MBP.Y/DB

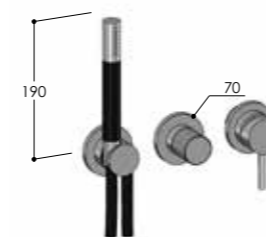

W3MBP.Y

Miscelatore bordo vasca da incasso con doccia
Concealed bathtub mixer with handshower
Mélangeur pour baignoire encastrable avec douche
Monomando empotrado de bañera con teleducha
UP-Badewannenmischer mit Handbrause

Corpo incasso_Concealed body_Corps encastré_Cuerpo empotrado_UP-Teil (pag. 209)

W3MP.INC

Parti esterne_External parts_Parties externes_Parties externas_AP-Teile

W3MBP.Y/MX

- W3MBP.Y/BX
- W3MBP.Y/MB
- W3MBP.Y/RL
- W3MBP.Y/BB
- W3MBP.Y/BC
- W3MBP.Y/AB
- W3MBP.Y/DB

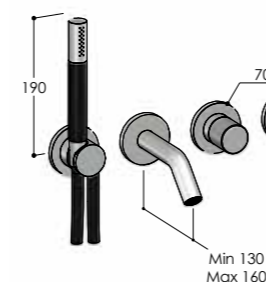

W4MBP.Y

Miscelatore bordo vasca da incasso con doccia
Concealed bathtub mixer with handshower
Mélangeur pour baignoire encastrable avec douche
Monomando empotrado de bañera con teleducha
UP-Badewannenmischer mit Handbrause

Corpo incasso_Concealed body_Corps encastré_Cuerpo empotrado_UP-Teil (pag. 209)

W4MP.INC

Parti esterne_External parts_Parties externes_Parties externas_AP-Teile

W4MBP.Y/MX

- W4MBP.Y/BX
- W4MBP.Y/MB
- W4MBP.Y/RL
- W4MBP.Y/BB
- W4MBP.Y/BC
- W4MBP.Y/AB
- W4MBP.Y/DB



CS40V.RC

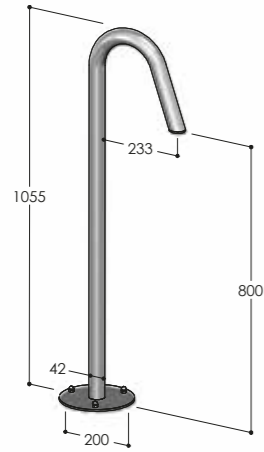

Colonna per vasca per comando remoto
 Bathtub column for remote control
 Colonne pour baignoire pour commande à distance
 Column de bañera para control remoto
 Badewannensäule für Fernsteuerung

- ✓ **CS40V.RC/MX**
 CS40V.RC/BX
 CS40V.RC/MB
 CS40V.RC/RL
- Corpo incasso_Concealed body_Corps encastré_Cuerpo empotrado_UP-Teil (pag. 209)
- CW.1**
- CW** Parti esterne_External parts_Parties externes_Parties externas_AP-Teile
- CS40V.XCW.RC/MX**
 CS40V.XCW.RC/BX
 CS40V.XCW.RC/MB
 CS40V.XCW.RC/RL



CS40V.M

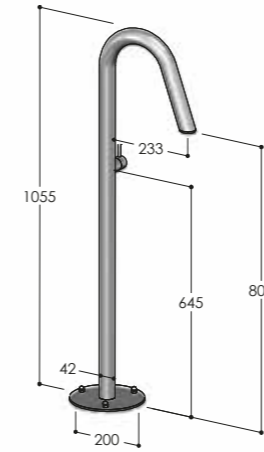

Colonna per vasca con miscelatore
 Bathtub column with mixer
 Colonne pour baignoire avec mitigeur
 Column de bañera con monomando
 Badewannensäule mit Einhebelmischer

- ✓ **CS40V.M/MX**
 CS40V.M/BX
 CS40V.M/MB
 CS40V.M/RL
- Corpo incasso_Concealed body_Corps encastré_Cuerpo empotrado_UP-Teil (pag. 209)
- CW.2**
- CW** Parti esterne_External parts_Parties externes_Parties externas_AP-Teile
- CS40V.XCW.M/MX**
 CS40V.XCW.M/BX
 CS40V.XCW.M/MB
 CS40V.XCW.M/RL

CS40V

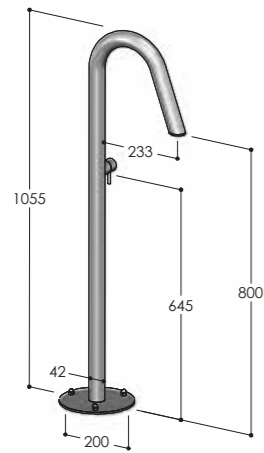

Colonna per vasca con rubinetto d'arresto
 Bathtub column with stop tap
 Colonne pour baignoire avec robinet d'arrêt
 Column de bañera con grifo
 Badewannensäule mit Wasserhahn

- ✓ **CS40V/MX**
 CS40V/BX
 CS40V/MB
 CS40V/RL
- Corpo incasso_Concealed body_Corps encastré_Cuerpo empotrado_UP-Teil (pag. 209)
- CW.1**
- CW** Parti esterne_External parts_Parties externes_Parties externas_AP-Teile
- CS40V.XCW/MX**
 CS40V.XCW/BX
 CS40V.XCW/MB
 CS40V.XCW/RL

CS40V.ME

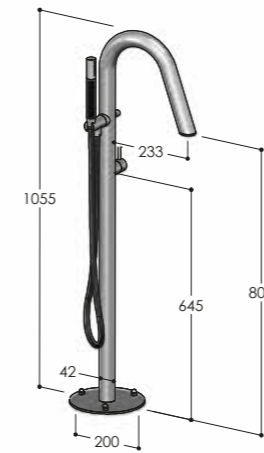

Colonna per vasca con miscelatore e doccia
 Bathtub column with mixer and handshower
 Colonne pour baignoire avec mitigeur et douchette
 Column de bañera con monomando y teleducha
 Badewannensäule mit Einhebelmischer und Handbrause

- ✓ **CS40V.ME/MX**
 CS40V.ME/BX
 CS40V.ME/MB
 CS40V.ME/RL
- Corpo incasso_Concealed body_Corps encastré_Cuerpo empotrado_UP-Teil (pag. 209)
- CW.2**
- CW** Parti esterne_External parts_Parties externes_Parties externas_AP-Teile
- CS40V.XCW.ME/MX**
 CS40V.XCW.ME/BX
 CS40V.XCW.ME/MB
 CS40V.XCW.ME/RL

CS40V.E

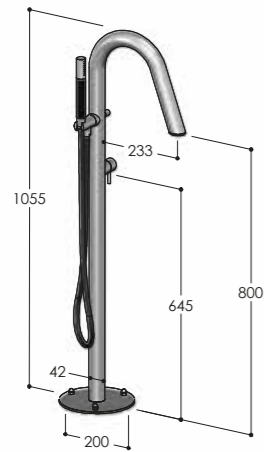

Colonna per vasca con rubinetto d'arresto e doccia
 Bathtub column with stop tap and handshower
 Colonne pour baignoire avec robinet d'arrêt et douchette
 Column de bañera con grifo y teleducha
 Badewannensäule mit Wasserhahn und Handbrause

- ✓ **CS40V.E/MX**
 CS40V.E/BX
 CS40V.E/MB
 CS40V.E/RL
- Corpo incasso_Concealed body_Corps encastré_Cuerpo empotrado_UP-Teil (pag. 209)
- CW.1**
- CW** Parti esterne_External parts_Parties externes_Parties externas_AP-Teile
- CS40V.XCW.E/MX**
 CS40V.XCW.E/BX
 CS40V.XCW.E/MB
 CS40V.XCW.E/RL

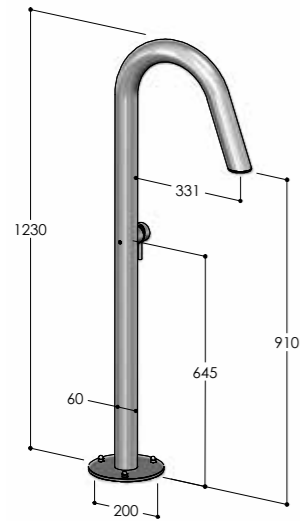

CS60V.HF.M

Colonna High-Flow per vasca con miscelatore
High-Flow bathtub column with mixer
Colonne High-Flow pour baignoire avec mitigeur
Columna de bañera High-Flow con monomando
High-Flow Badewannensäule mit Einhebelmischer

✓	CS60V.HF.M/MX CS60V.HF.M/BX CS60V.HF.M/MB CS60V.HF.M/RL
	Corpo incasso_Concealed body_Corps encastré_Cuerpo empotrado_UP-Teil (pag. 209)
	CW.2
CW	Parti esterne_External parts_Parties externes_Parties externas_AP-Teile CS60V.HF.XCW.M/MX CS60V.HF.XCW.M/BX CS60V.HF.XCW.M/MB CS60V.HF.XCW.M/RL
4S	CS60V.HF.4S.M/MX CS60V.HF.4S.M/BX CS60V.HF.4S.M/MB CS60V.HF.4S.M/RL

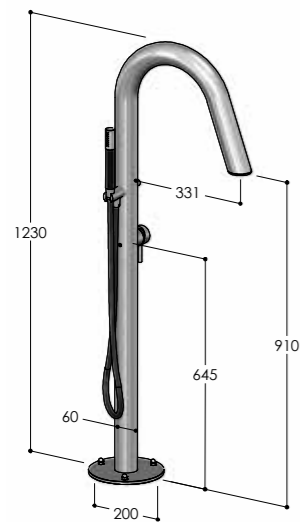

CS60V.HF.ME

Colonna High-Flow per vasca con miscelatore e doccia
High-Flow bathtub column with mixer and handshower
Colonne High-Flow pour baignoire avec mitigeur et douchette
Columna de bañera High-Flow con monomando y teleducha
High-Flow Badewannensäule mit Einhebelmischer und Handbrause



✓	CS60V.HF.ME/MX CS60V.HF.ME/BX CS60V.HF.ME/MB CS60V.HF.ME/RL
	Corpo incasso_Concealed body_Corps encastré_Cuerpo empotrado_UP-Teil (pag. 209)
	CW.2
CW	Parti esterne_External parts_Parties externes_Parties externas_AP-Teile CS60V.HF.XCW.ME/MX CS60V.HF.XCW.ME/BX CS60V.HF.XCW.ME/MB CS60V.HF.XCW.ME/RL
4S	CS60V.HF.4S.ME/MX CS60V.HF.4S.ME/BX CS60V.HF.4S.ME/MB CS60V.HF.4S.ME/RL



ST.Y

Rubinetto incasso
Concealed tap
Robinet d'arrêt encastrable
Llave de paso
UP-Ventil

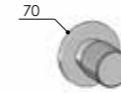

Corpo incasso_Concealed body_Corps encastré_Cuerpo empotrado_UP-Teil (pag. 209)

ST.INC
Parti esterne_External parts_Parties externes_Parties externas_AP-Teile
ST.Y/MX
ST.Y/BX
ST.Y/MB
ST.Y/RL
ST.Y/BB
ST.Y/BC
ST.Y/AB
ST.Y/DB

MR

Miscelatore da incasso per doccia
Concealed shower mixer
Mitigeur de douche à encastrer
Monomando de ducha mural
UP-Brausemischer

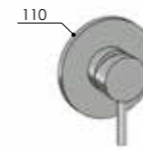

Corpo incasso_Concealed body_Corps encastré_Cuerpo empotrado_UP-Teil (pag. 209)

MR.INC
Parti esterne_External parts_Parties externes_Parties externas_AP-Teile
MR/MX
MR/BX
MR/MB
MR/RL
MR/BB
MR/BC
MR/AB
MR/DB

MR2.Y

Miscelatore da incasso per doccia, con deviatore a 2 vie
Concealed shower mixer with 2-ways diverter
Mitigeur de douche encastrable avec inverseur à 2 voies
Monomando empotrado para ducha con desviador 2 salidas
UP-Brausemischer mit 2-Wege Umsteller



Corpo incasso_Concealed body_Corps encastré_Cuerpo empotrado_UP-Teil (pag. 209)

MR2.INC
Parti esterne_External parts_Parties externes_Parties externas_AP-Teile
MR2.Y/MX
MR2.Y/BX
MR2.Y/MB
MR2.Y/RL
MR2.Y/BB
MR2.Y/BC
MR2.Y/AB
MR2.Y/DB

MR3.Y

Miscelatore da incasso per doccia, con deviatore a 3 vie
Concealed shower mixer with 3-ways diverter
Mitigeur de douche encastrable avec inverseur à 3 voies
Monomando empotrado para ducha con desviador 3 salidas
UP-Brausemischer mit 3-Wege Umsteller

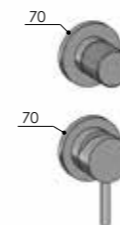

Corpo incasso_Concealed body_Corps encastré_Cuerpo empotrado_UP-Teil (pag. 209)

MR3.INC
Parti esterne_External parts_Parties externes_Parties externas_AP-Teile
MR3.Y/MX
MR3.Y/BX
MR3.Y/MB
MR3.Y/RL
MR3.Y/BB
MR3.Y/BC
MR3.Y/AB
MR3.Y/DB

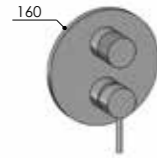

MX2.Y



Miscelatore da incasso per doccia, con deviatore a 2 vie
 Concealed shower mixer with 2-ways diverter
 Mitigeur de douche encastrable avec inverseur à 2 voies
 Monomando empotrado para ducha con desviador 2 salidas
 UP-Brausemischer mit 2-Wege Umsteller

Corpo incasso_Concealed body_Corps encastré_Cuerpo empotrado_UP-Teil (pag. 209)

MX.INC

Parti esterne_External parts_Parties externes_Parties externas_AP-Teile

MX2.Y/MX

- MX2.Y/BX
- MX2.Y/MB
- MX2.Y/RL
- MX2.Y/BB
- MX2.Y/BC
- MX2.Y/AB
- MX2.Y/DB

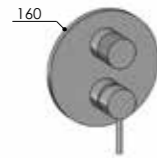

MX3.Y



Miscelatore da incasso per doccia, con deviatore a 3 vie
 Concealed shower mixer with 3-ways diverter
 Mitigeur de douche encastrable avec inverseur à 3 voies
 Monomando empotrado para ducha con desviador 3 salidas
 UP-Brausemischer mit 3-Wege Umsteller

Corpo incasso_Concealed body_Corps encastré_Cuerpo empotrado_UP-Teil (pag. 209)

MX.INC

Parti esterne_External parts_Parties externes_Parties externas_AP-Teile

MX3.Y/MX

- MX3.Y/BX
- MX3.Y/MB
- MX3.Y/RL
- MX3.Y/BB
- MX3.Y/BC
- MX3.Y/AB
- MX3.Y/DB

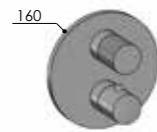

TC1.Y



Miscelatore termostatico da incasso per doccia
 Concealed thermostatic mixer for shower
 Mitigeur thermostatique de douche
 Mezclador termostatico empotrado para ducha
 UP-Thermostat-Brausemischer

Corpo incasso_Concealed body_Corps encastré_Cuerpo empotrado_UP-Teil (pag. 209)

MX.INC

Parti esterne_External parts_Parties externes_Parties externas_AP-Teile

TC1.Y/MX

- TC1.Y/BX
- TC1.Y/MB
- TC1.Y/RL
- TC1.Y/BB
- TC1.Y/BC
- TC1.Y/AB
- TC1.Y/DB

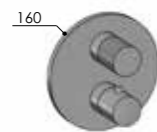

TC2.Y



Miscelatore termostatico da incasso per doccia, 2 vie
 Concealed thermostatic mixer for shower, 2-ways
 Mitigeur thermostatique de douche, 2-voies
 Mezclador termostatico empotrado para ducha, 2-salidas
 UP-Thermostat-Brausemischer, 2-Wege

Corpo incasso_Concealed body_Corps encastré_Cuerpo empotrado_UP-Teil (pag. 209)

MX.INC

Parti esterne_External parts_Parties externes_Parties externas_AP-Teile

TC2.Y/MX

- TC2.Y/BX
- TC2.Y/MB
- TC2.Y/RL
- TC2.Y/BB
- TC2.Y/BC
- TC2.Y/AB
- TC2.Y/DB

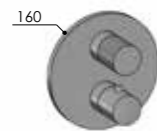

TC3.Y



Miscelatore termostatico da incasso per doccia, 3 vie
 Concealed thermostatic mixer for shower, 3-ways
 Mitigeur thermostatique de douche, 3-voies
 Mezclador termostatico empotrado para ducha, 3-salidas
 UP-Thermostat-Brausemischer, 3-Wege

Corpo incasso_Concealed body_Corps encastré_Cuerpo empotrado_UP-Teil (pag. 209)

MX.INC

Parti esterne_External parts_Parties externes_Parties externas_AP-Teile

TC3.Y/MX

- TC3.Y/BX
- TC3.Y/MB
- TC3.Y/RL
- TC3.Y/BB
- TC3.Y/BC
- TC3.Y/AB
- TC3.Y/DB

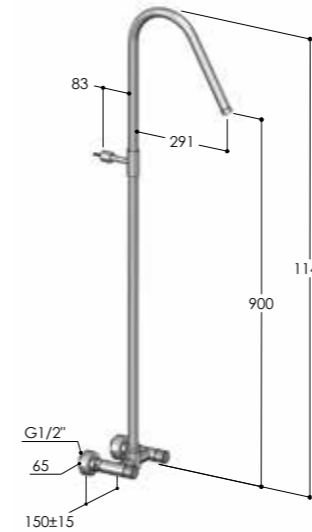

W810



Gruppo esterno con colonna doccia e soffione incassato
 Wall-mounted shower mixer, with column and concealed showerhead
 Mélangeur douche avec colonne et pomme de douche intégrée
 Batería para ducha con columna y rociador integrado
 AP-Brausebatterie mit Stange und integrierter Kopfbrause

W810/MX

- W810/BX
- W810/MB
- W810/RL
- W810/BB
- W810/BC
- W810/AB
- W810/DB

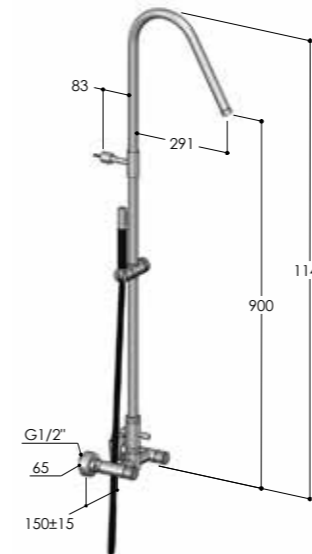

W810.E



Gruppo esterno con colonna doccia, soffione incassato e doccia
 Wall-mounted shower mixer, with column, concealed showerhead and handshower
 Mélangeur douche avec colonne, pomme de douche intégrée et douchette
 Batería para ducha con columna, rociador integrado y teleducha
 AP-Brausebatterie mit Stange, integrierter Kopfbrause und Handbrause

W810.E/MX

- W810.E/BX
- W810.E/MB
- W810.E/RL
- W810.E/BB
- W810.E/BC
- W810.E/AB
- W810.E/DB

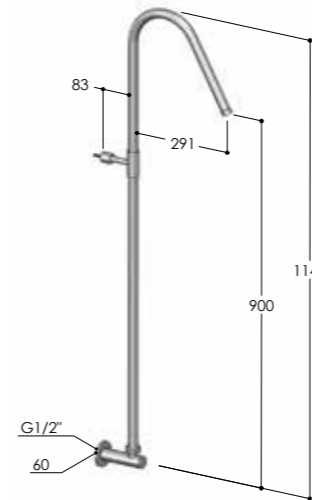

W8X1

Preso d'acqua con colonna doccia e soffione incassato
 Wall coupling, with column and concealed showerhead
 Coude de sortie, avec colonne et pomme de douche intégrée
 Codo mural, con columna y rociador integrado
 Wandanschlußbogen mit Stange und integrierter Kopfbrause

W8X1/MX

- W8X1/BX
- W8X1/MB
- W8X1/RL
- W8X1/BB
- W8X1/BC
- W8X1/AB
- W8X1/DB

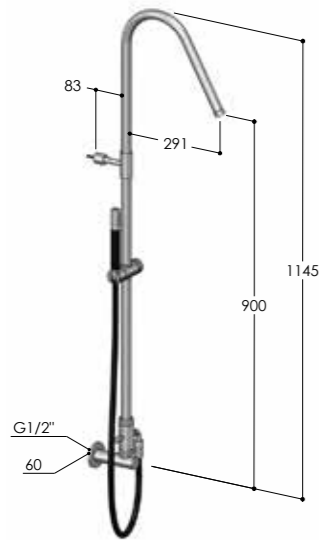

W8X1.E

Presad'acqua con colonna doccia, soffione incassato e doccetta
 Wall coupling, with column, concealed showerhead and handshower
 Coude de sortie, avec colonne, pomme de douche intégrée et douchette
 Codo mural, con columna, rociador integrado y teleducha
 Wandanschlußbogen mit Stange, integrierter Kopfbrause und Handbrause



W8X1.E/MX

- W8X1.E/BX
- W8X1.E/MB
- W8X1.E/RL
- W8X1.E/BB
- W8X1.E/BC
- W8X1.E/AB
- W8X1.E/DB

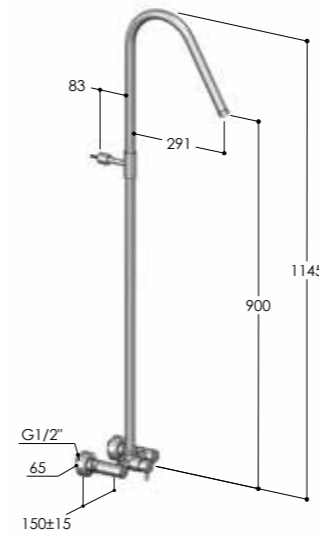

W883

Miscelatore esterno con colonna doccia e soffione incassato
 Wall-mounted mixer, with column and concealed showerhead
 Mitigeur mural avec colonne et pomme de douche intégrée
 Mezclador mural con columna y rociador integrado
 AP-Brausemischer mit Stange und integrierter Kopfbrause

W883/MX

- W883/BX
- W883/MB
- W883/RL
- W883/BB
- W883/BC
- W883/AB
- W883/DB

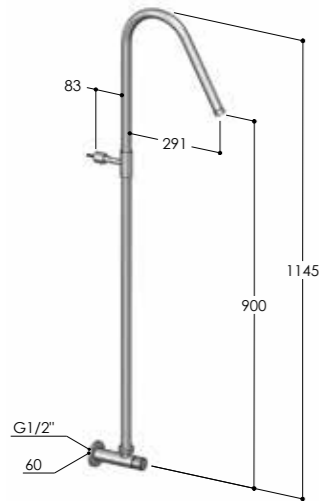

W812

Rubinetto esterno con colonna doccia e soffione incassato
 Wall-mounted tap with column and concealed showerhead
 Robinet mural avec colonne et pomme de douche intégrée
 Grifo mural con columna y rociador integrado
 AP-Ventil mit Stange und integrierter Kopfbrause

W812/MX

- W812/BX
- W812/MB
- W812/RL
- W812/BB
- W812/BC
- W812/AB
- W812/DB

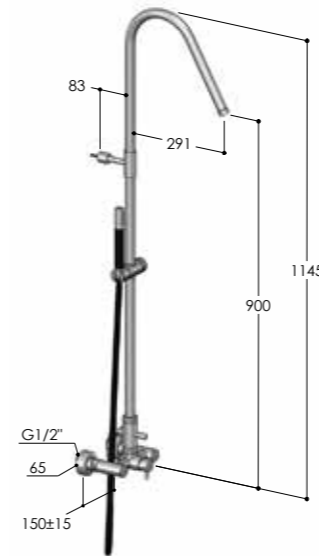

W883.E

Miscelatore esterno con colonna doccia, soffione incassato e doccetta
 Wall-mounted mixer, with column, concealed showerhead and handshower
 Mitigeur mural avec colonne, pomme de douche intégrée et douchette
 Mezclador mural con columna, rociador integrado y teleducha
 AP-Brausemischer mit Stange, integrierter Kopfbrause und Handbrause

W883.E/MX

- W883.E/BX
- W883.E/MB
- W883.E/RL
- W883.E/BB
- W883.E/BC
- W883.E/AB
- W883.E/DB

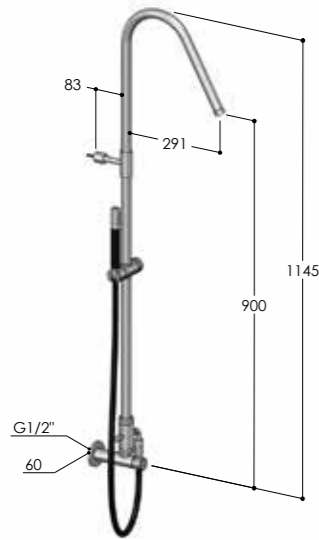

W812.E

Rubinetto esterno con colonna doccia, soffione incassato e doccetta
 Wall-mounted tap with column, concealed showerhead and handshower
 Robinet mural avec colonne, pomme de douche intégrée et douchette
 Grifo mural con columna, rociador integrado y teleducha
 AP-Ventil mit Stange, integrierter Kopfbrause und Handbrause



W812.E/MX

- W812.E/BX
- W812.E/MB
- W812.E/RL
- W812.E/BB
- W812.E/BC
- W812.E/AB
- W812.E/DB

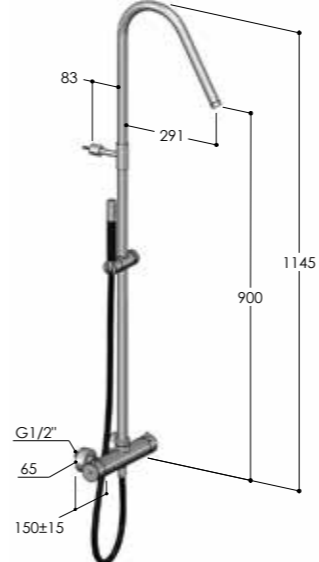

W875.E

Miscelatore termostatico esterno con colonna doccia, soffione incassato e doccetta
 Wall-mounted thermostatic mixer, with column, concealed showerhead and handshower
 Mitigeur thermostatique mural avec colonne, pomme de douche intégrée et douchette
 Mezclador termostatico mural con columna, rociador integrado y teleducha
 AP-Thermostat-Brausemischer mit Stange, integrierter Kopfbrause und Handbrause



W875.E/MX

- W875.E/BX
- W875.E/MB
- W875.E/RL
- W875.E/BB
- W875.E/BC
- W875.E/AB
- W875.E/DB

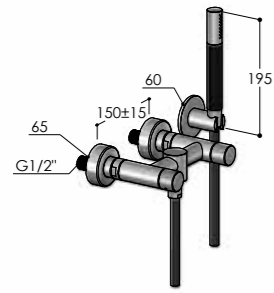

WX10.SK

Gruppo esterno con kit doccia
Wall-mounted mixer with shower kit
Mélangeur mural avec kit de douche
Bateria con kit de ducha mural
AP-Batterie mit Brausekit

WX10.SK/MX

- WX10.SK/BX
- WX10.SK/MB
- WX10.SK/RL
- WX10.SK/BB
- WX10.SK/BC
- WX10.SK/AB
- WX10.SK/DB

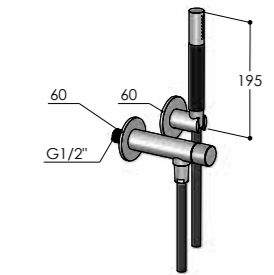

WX12.SK

Rubinetto esterno con kit doccia
Wall-mounted tap with shower kit
Robinet mural avec kit de douche
Grifo mural con kit de ducha
AP-Ventil, mit Brausekit

WX12.SK/MX

- WX12.SK/BX
- WX12.SK/MB
- WX12.SK/RL
- WX12.SK/BB
- WX12.SK/BC
- WX12.SK/AB
- WX12.SK/DB

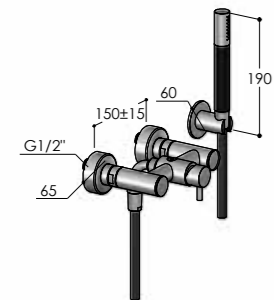

WX83.SK

Miscelatore esterno con kit doccia
Wall-mounted mixer with shower kit
Mitigeur mural avec kit de douche
Mezclador mural con kit de ducha
AP-Brausemischer mit Brausekit

WX83.SK/MX

- WX83.SK/BX
- WX83.SK/MB
- WX83.SK/RL
- WX83.SK/BB
- WX83.SK/BC
- WX83.SK/AB
- WX83.SK/DB

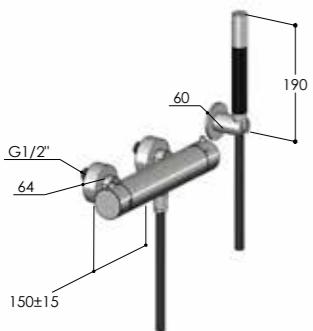

WX75.SK

Miscelatore termostatico esterno con kit doccia
Wall-mounted thermostatic mixer with shower kit
Mitigeur thermostatique mural avec kit de douche
Mezclador termostatico mural con kit de ducha
AP-Thermostat-Brausemischer mit Brausekit

WX75.SK/MX

- WX75.SK/BX
- WX75.SK/MB
- WX75.SK/RL
- WX75.SK/BB
- WX75.SK/BC
- WX75.SK/AB
- WX75.SK/DB

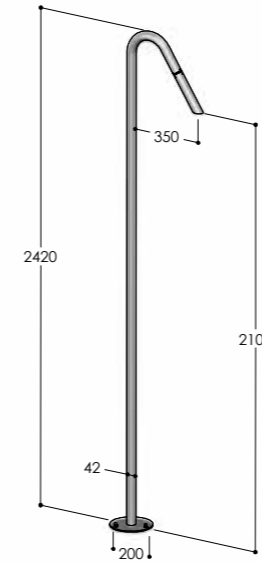

CSR40.RC

Colonna doccia con soffione aerato per comando remoto
Shower column with aerated showerhead for remote control
Colonne douche avec pomme de douche avec jet moussé pour commande à distance
Column de ducha con rociador chorro aireado para control remoto
Duschsäule mit Fein-Strahl-Dusche für Fernsteuerung

CSR40.RC/MX

- CSR40.RC/BX
- CSR40.RC/MB
- CSR40.RC/RL

Corpo incasso_Concealed body_Corps encastré_Cuerpo empotrado_UP-Teil (pag. 209)

CW.1

Parti esterne_External parts_Parties externes_Parties externas_AP-Teile

CSR40.XCW.RC/MX

- CSR40.XCW.RC/BX
- CSR40.XCW.RC/MB
- CSR40.XCW.RC/RL

CSR40.EW.RC/MX

- CSR40.EW.RC/BX
- CSR40.EW.RC/MB
- CSR40.EW.RC/RL

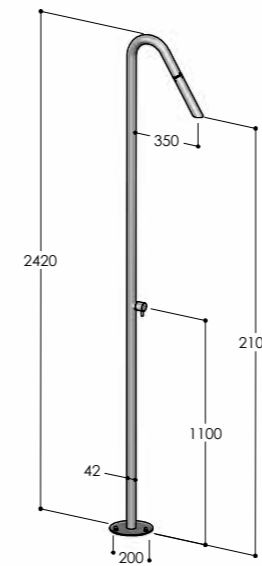

CSR40

Colonna doccia con rubinetto d'arresto e soffione aerato
Shower column with stop tap and aerated showerhead
Colonne douche avec robinet d'arrêt et pomme de douche avec jet moussé
Column de ducha con grifo y rociador chorro aireado
Duschsäule mit Wasserhahn und Fein-Strahl-Dusche

CSR40/MX

- CSR40/BX
- CSR40/MB
- CSR40/RL

Corpo incasso_Concealed body_Corps encastré_Cuerpo empotrado_UP-Teil (pag. 209)

CW.1

Parti esterne_External parts_Parties externes_Parties externas_AP-Teile

CSR40.XCW/MX

- CSR40.XCW/BX
- CSR40.XCW/MB
- CSR40.XCW/RL

CSR40.EW/MX

- CSR40.EW/BX
- CSR40.EW/MB
- CSR40.EW/RL

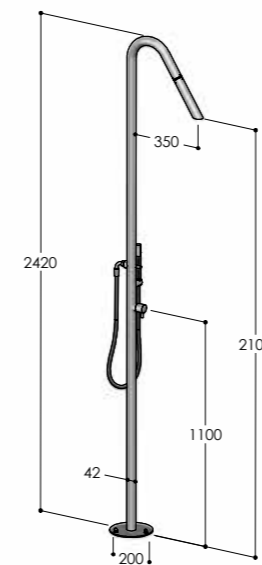

CSR40.E

Colonna doccia con rubinetto d'arresto, soffione aerato e doccia
Shower column with stop tap, aerated showerhead and handshower
Colonne douche avec robinet d'arrêt, pomme de douche avec jet moussé et douchette
Column de ducha con grifo, rociador chorro aireado y teleducha
Duschsäule mit Wasserhahn, Fein-Strahl-Dusche und Handbrause

CSR40.E/MX

- CSR40.E/BX
- CSR40.E/MB
- CSR40.E/RL

Corpo incasso_Concealed body_Corps encastré_Cuerpo empotrado_UP-Teil (pag. 209)

CW.1

Parti esterne_External parts_Parties externes_Parties externas_AP-Teile

CSR40.XCW.E/MX

- CSR40.XCW.E/BX
- CSR40.XCW.E/MB
- CSR40.XCW.E/RL

CSR40.EW.E/MX

- CSR40.EW.E/BX
- CSR40.EW.E/MB
- CSR40.EW.E/RL

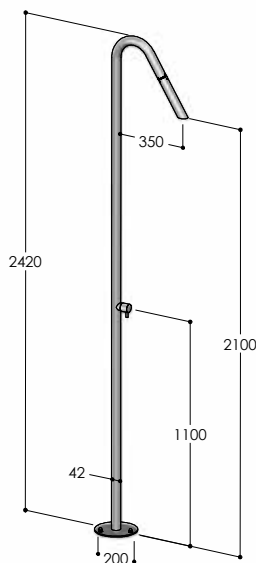

CSR40.M



Colonna doccia con miscelatore e soffione aerato

Shower column with mixer and aerated showerhead

Colonne douche avec mitigeur et pomme de douche avec jet moussé

Column de ducha con monomando y rociador chorro aireado

Duschsäule mit Einhebelmischer und Fein-Strahl-Dusche

✓	CSR40.M/MX	
	CSR40.M/BX	
	CSR40.M/MB	
	CSR40.M/RL	
CW	Corpo incasso_Concealed body_Corps encastré_Cuerpo empotrado_UP-Teil (pag. 209)	
	CW.1	
	Parti esterne_External parts_Parties externes_Parties externas_AP-Teile	
	CSR40.XCW.M/MX	
	CSR40.XCW.M/BX	
	CSR40.XCW.M/MB	
	CSR40.XCW.M/RL	
	EW	CSR40.EW.M/MX
		CSR40.EW.M/BX
		CSR40.EW.M/MB
CSR40.EW.M/RL		

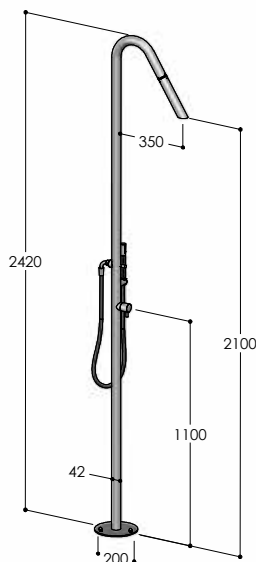

CSR40.ME



Colonna doccia con miscelatore, soffione aerato e doccia

Shower column with mixer, aerated showerhead and handshower

Colonne douche avec mitigeur, pomme de douche avec jet moussé et douchette

Column de ducha con monomando, rociador chorro aireado y teleducha

Duschsäule mit Einhebelmischer, Fein-Strahl-Dusche und Handbrause

✓	CSR40.ME/MX	
	CSR40.ME/BX	
	CSR40.ME/MB	
CW	Corpo incasso_Concealed body_Corps encastré_Cuerpo empotrado_UP-Teil (pag. 209)	
	CW.1	
	Parti esterne_External parts_Parties externes_Parties externas_AP-Teile	
	CSR40.XCW.ME/MX	
	CSR40.XCW.ME/BX	
	CSR40.XCW.ME/MB	
	CSR40.XCW.ME/RL	
	EW	CSR40.EW.ME/MX
		CSR40.EW.ME/BX
		CSR40.EW.ME/MB
CSR40.EW.ME/RL		



BOSS

Basin	<i>pag. 70</i>
Bathtub	<i>pag. 74</i>
Shower	<i>pag. 79</i>



BOSS

**CD35**

Miscelatore da lavabo
Washbasin mixer
Mitigeur de lavabo
Monomando de lavabo
Waschtischmischer

CD35/MX

CD35/BX
CD35/MB
CD35/RL
CD35/BB
CD35/BC
CD35/AB
CD35/DB

**CD35H**

Miscelatore alto da lavabo
Washbasin pillar mixer
Mitigeur haut de lavabo
Monomando de lavabo alto
Waschtischmischer hoch

CD35H/MX

CD35H/BX
CD35H/MB
CD35H/RL
CD35H/BB
CD35H/BC
CD35H/AB
CD35H/DB

**CD35B**

Miscelatore da bidet
Bidet mixer
Mitigeur de bidet
Monomando de bidet
Bidetmischer

CD35B/MX

CD35B/BX
CD35B/MB
CD35B/RL
CD35B/BB
CD35B/BC
CD35B/AB
CD35B/DB

**W3.CD**

Batteria da lavabo 3 fori
Basin set 3-holes
Mélangeur de lavabo 3 trous
Bateria para lavabo 3 agujeros
3-Loch Waschtischbatterie

W3.CD/MX

W3.CD/BX
W3.CD/MB
W3.CD/RL
W3.CD/BB
W3.CD/BC
W3.CD/AB
W3.CD/DB

**W2M.CD**

Miscelatore da bordo lavabo
Deck-mounted washbasin mixer
Mitigeur de lavabo, montage sur gorge
Monomando para borde de lavabo
Waschtisch-Batterie für Randmontage

W2M.CD/MX

W2M.CD/BX
W2M.CD/MB
W2M.CD/RL
W2M.CD/BB
W2M.CD/BC
W2M.CD/AB
W2M.CD/DB

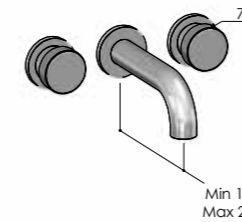
**W3P.CD**

Batteria lavabo da incasso
Concealed washbasin set
Mélangeur lavabo à encastrer
Bateria mural de lavabo
Wandmontierte-Waschtisch-Batterie

Corpo incasso_Concealed body_Corps encastré_Cuerpo empotrado_UP-Teil (pag. 209)

W3P.INC

Parti esterne_External parts_Parties externes_Parties externas_AP-Teile

W3P.CD/MX

W3P.CD/BX
W3P.CD/MB
W3P.CD/RL
W3P.CD/BB
W3P.CD/BC
W3P.CD/AB
W3P.CD/DB

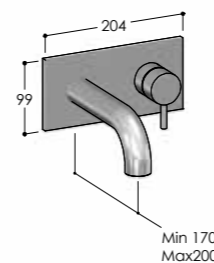
**W2MP.CD**

Miscelatore lavabo da incasso
Concealed washbasin mixer
Mitigeur lavabo à encastrer
Monomando mural de lavabo
UP-Waschtisch-Einhandbatterie

Corpo incasso_Concealed body_Corps encastré_Cuerpo empotrado_UP-Teil (pag. 209)

W2MP.INC

Parti esterne_External parts_Parties externes_Parties externas_AP-Teile

W2MP.CD/MX

W2MP.CD/BX
W2MP.CD/MB
W2MP.CD/RL
W2MP.CD/BB
W2MP.CD/BC
W2MP.CD/AB
W2MP.CD/DB

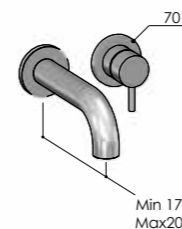
**W2MP.2.CD**

Miscelatore lavabo da incasso
Concealed washbasin mixer
Mitigeur lavabo à encastrer
Monomando mural de lavabo
UP-Waschtisch-Einhandbatterie

Corpo incasso_Concealed body_Corps encastré_Cuerpo empotrado_UP-Teil (pag. 209)

W2MP.2.INC

Parti esterne_External parts_Parties externes_Parties externas_AP-Teile

W2MP.2.CD/MX

W2MP.2.CD/BX
W2MP.2.CD/MB
W2MP.2.CD/RL
W2MP.2.CD/BB
W2MP.2.CD/BC
W2MP.2.CD/AB
W2MP.2.CD/DB

WMRL

Miscelatore da incasso per lavabo
 Concealed mixer for washbasin
 Mitiguer encastrable pour lavabo
 Monomando empotrado para lavabo
 Waschtischmischer

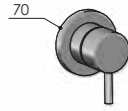

Corpo incasso_Concealed body_Corps encastré_Cuerpo empotrado_UP-Teil (pag. 209)

MR.INC

Parti esterne_External parts_Parties externes_Parties externas_AP-Teile

WMRL/MX

WMRL/BX

WMRL/MB

WMRL/RL

WMRL/BB

WMRL/BC

WMRL/AB

WMRL/DB

SP.CD

Bocca a parete
 Wall-mounted spout
 Bec déverseur
 Caño mural
 Wandmontierter Wanneneinlauf

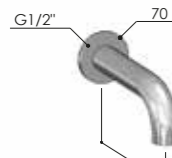

Min 170
 Max 200

SP.CD/MX

SP.CD/BX

SP.CD/MB

SP.CD/RL

SP.CD/BB

SP.CD/BC

SP.CD/AB

SP.CD/DB

B40L.RC

Colonna per lavabo per comando remoto
 Washbasin column for remote control
 Colonne pour lavabo pour commande à distance
 Column de lavabo para control remoto
 Waschtischsäule für Fernsteuerung

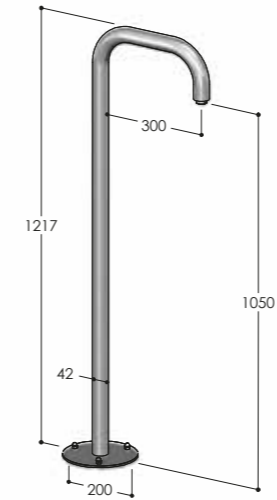
**B40L.RC/MX**

B40L.RC/BX

B40L.RC/MB

B40L.RC/RL

Corpo incasso_Concealed body_Corps encastré_Cuerpo empotrado_UP-Teil (pag. 209)

CW.1

Parti esterne_External parts_Parties externes_Parties externas_AP-Teile

B40L.XCW.RC/MX

B40L.XCW.RC/BX

B40L.XCW.RC/MB

B40L.XCW.RC/RL

B40L

Colonna per lavabo con rubinetto d'arresto
 Washbasin column with stop tap
 Colonne pour lavabo avec robinet d'arrêt
 Column de lavabo con grifo
 Waschtischsäule mit Wasserhahn

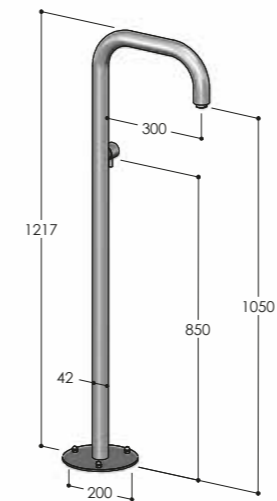
**B40L/MX**

B40L/BX

B40L/MB

B40L/RL

Corpo incasso_Concealed body_Corps encastré_Cuerpo empotrado_UP-Teil (pag. 209)

CW.1

Parti esterne_External parts_Parties externes_Parties externas_AP-Teile

B40L.XCW/MX

B40L.XCW/BX

B40L.XCW/MB

B40L.XCW/RL

B40L.M

Colonna per lavabo con miscelatore
 Washbasin column with mixer
 Colonne pour lavabo avec mitigeur
 Column de lavabo con monomando
 Waschtischsäule mit Einhebelmischer

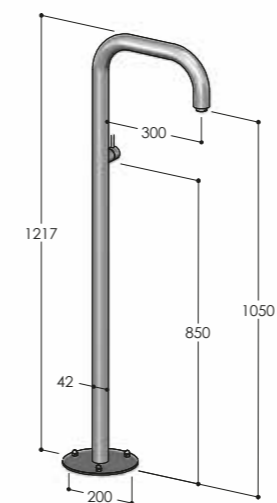
**B40L.M/MX**

B40L.M/BX

B40L.M/MB

B40L.M/RL

Corpo incasso_Concealed body_Corps encastré_Cuerpo empotrado_UP-Teil (pag. 209)

CW.2

Parti esterne_External parts_Parties externes_Parties externas_AP-Teile

B40L.XCW.M/MX

B40L.XCW.M/BX

B40L.XCW.M/MB

B40L.XCW.M/RL

**W3B.CD**

Batteria bordo vasca 3 fori
Bathtub set 3-holes
Mélangeur de baignoire pour montage sur gorge, 3 trous
Bateria para borde de bañera, 3 agujeros
3-Loch Badewannenbatterie für Randmontage

W3B.CD/MX

W3B.CD/BX
W3B.CD/MB
W3B.CD/RL
W3B.CD/BB
W3B.CD/BC
W3B.CD/AB
W3B.CD/DB

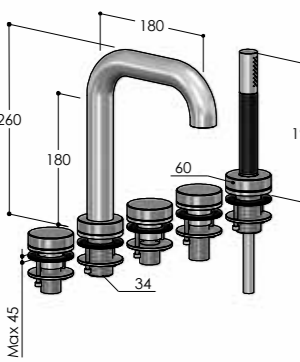
**W5B.CD**

Batteria bordo vasca 5 fori
Bathtub set 5-holes
Mélangeur de baignoire pour montage sur gorge, 5 trous
Bateria para borde de bañera, 5 agujeros
5-Loch Badewannenbatterie für Randmontage

W5B.CD/MX

W5B.CD/BX
W5B.CD/MB
W5B.CD/RL
W5B.CD/BB
W5B.CD/BC
W5B.CD/AB
W5B.CD/DB

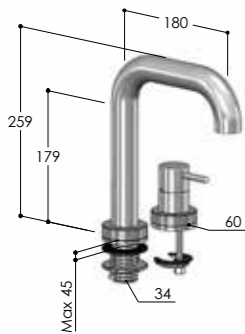
**W2MB.CD**

Miscelatore per bordo vasca
Deck-mounted bathtub mixer
Mitigeur de baignoire pour montage sur gorge
Monomando de repisa para bañera
Badewannenmischer für Randmontage

W2MB.CD/MX

W2MB.CD/BX
W2MB.CD/MB
W2MB.CD/RL
W2MB.CD/BB
W2MB.CD/BC
W2MB.CD/AB
W2MB.CD/DB

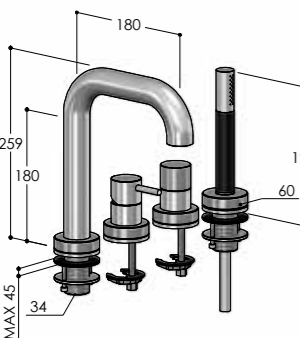
**W4MB.CD**

Miscelatore per bordo vasca con doccia
Deck-mounted bathtub mixer with handshower
Mitigeur de baignoire pour montage sur gorge avec douche
Monomando de repisa para bañera con teleducha
Badewannenmischer für Randmontage mit Handbrause

W4MB.CD/MX

W4MB.CD/BX
W4MB.CD/MB
W4MB.CD/RL
W4MB.CD/BB
W4MB.CD/BC
W4MB.CD/AB
W4MB.CD/DB

**W2MBP.CD**

Miscelatore bordo vasca da incasso
Concealed bathtub mixer
Mélangeur pour baignoire encastrable
Monomando empotrado de bañera
UP-Badewannenmischer

Corpo incasso_Concealed body_Corps encastré_Cuerpo empotrado_UP-Teil (pag. 209)

W2MP.INC

Parti esterne_External parts_Parties externes_Parties externas_AP-Teile

W2MBP.CD/MX

W2MBP.CD/BX
W2MBP.CD/MB
W2MBP.CD/RL
W2MBP.CD/BB
W2MBP.CD/BC
W2MBP.CD/AB
W2MBP.CD/DB

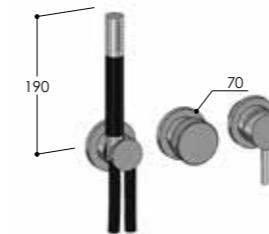
**W3MBP.CD**

Miscelatore bordo vasca da incasso con doccia
Concealed bathtub mixer with handshower
Mélangeur pour baignoire encastrable avec douche
Monomando empotrado de bañera con teleducha
UP-Badewannenmischer mit Handbrause

Corpo incasso_Concealed body_Corps encastré_Cuerpo empotrado_UP-Teil (pag. 209)

W3MP.INC

Parti esterne_External parts_Parties externes_Parties externas_AP-Teile

W3MBP.CD/MX

W3MBP.CD/BX
W3MBP.CD/MB
W3MBP.CD/RL
W3MBP.CD/BB
W3MBP.CD/BC
W3MBP.CD/AB
W3MBP.CD/DB

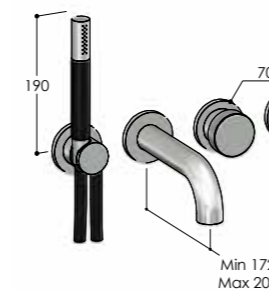
**W4MBP.CD**

Miscelatore bordo vasca da incasso con doccia
Concealed bathtub mixer with handshower
Mélangeur pour baignoire encastrable avec douche
Monomando empotrado de bañera con teleducha
UP-Badewannenmischer mit Handbrause

Corpo incasso_Concealed body_Corps encastré_Cuerpo empotrado_UP-Teil (pag. 209)

W4MP.INC

Parti esterne_External parts_Parties externes_Parties externas_AP-Teile

W4MBP.CD/MX

W4MBP.CD/BX
W4MBP.CD/MB
W4MBP.CD/RL
W4MBP.CD/BB
W4MBP.CD/BC
W4MBP.CD/AB
W4MBP.CD/DB

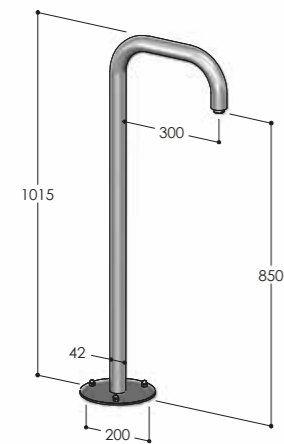
**B40V.RC**

Colonna per vasca per comando remoto
Bathtub column for remote control
Colonne pour baignoire pour commande à distance
Column de bañera para control remoto
Badewannensäule für Fernsteuerung

B40V.RC/MX

B40V.RC/BX
B40V.RC/MB
B40V.RC/RL

Corpo incasso_Concealed body_Corps encastré_Cuerpo empotrado_UP-Teil (pag. 209)

CW.1

Parti esterne_External parts_Parties externes_Parties externas_AP-Teile

B40V.XCW.RC/MX

B40V.XCW.RC/BX
B40V.XCW.RC/MB
B40V.XCW.RC/RL

B40V.M

Colonna per vasca con miscelatore
Bathtub column with mixer
Colonne pour baignoire avec mitigeur
Column de bañera con monomando
Badewannensäule mit Einhebelmischer

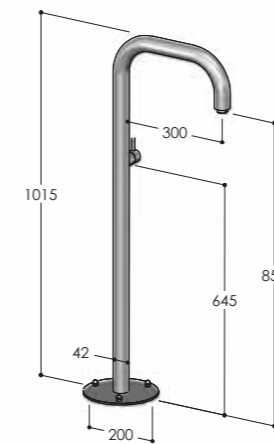
**B40V.M/MX**

B40V.M/BX
B40V.M/MB
B40V.M/RL

Corpo incasso_Concealed body_Corps encastré_Cuerpo empotrado_UP-Teil (pag. 209)

CW.2

Parti esterne_External parts_Parties externes_Parties externas_AP-Teile

B40V.XCW.M/MX

B40V.XCW.M/BX
B40V.XCW.M/MB
B40V.XCW.M/RL

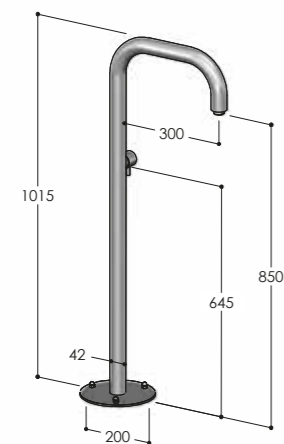
B40V

Colonna per vasca con rubinetto d'arresto
Bathtub column with stop tap
Colonne pour baignoire avec robinet d'arrêt
Column de bañera con grifo
Badewannensäule mit Wasserhahn

B40V/MX

B40V/BX
B40V/MB
B40V/RL

Corpo incasso_Concealed body_Corps encastré_Cuerpo empotrado_UP-Teil (pag. 209)

CW.1

Parti esterne_External parts_Parties externes_Parties externas_AP-Teile

B40V.XCW/MX

B40V.XCW/BX
B40V.XCW/MB
B40V.XCW/RL

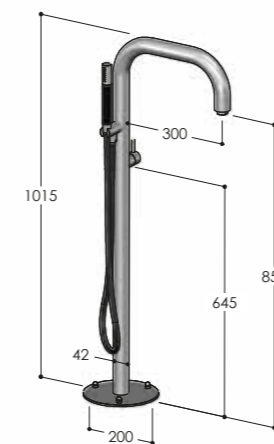
B40V.ME

Colonna per vasca con miscelatore e doccia
Bathtub column with mixer and handshower
Colonne pour baignoire avec mitigeur et douchette
Column de bañera con monomando y teleducha
Badewannensäule mit Einhebelmischer und Handbrause

B40V.ME/MX

B40V.ME/BX
B40V.ME/MB
B40V.ME/RL

Corpo incasso_Concealed body_Corps encastré_Cuerpo empotrado_UP-Teil (pag. 209)

CW.2

Parti esterne_External parts_Parties externes_Parties externas_AP-Teile

B40V.XCW.ME/MX

B40V.XCW.ME/BX
B40V.XCW.ME/MB
B40V.XCW.ME/RL

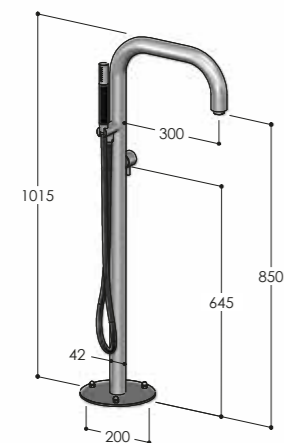
B40V.E

Colonna per vasca con rubinetto d'arresto e doccia
Bathtub column with stop tap and handshower
Colonne pour baignoire avec robinet d'arrêt et douchette
Column de bañera con grifo y teleducha
Badewannensäule mit Wasserhahn und Handbrause

B40V.E/MX

B40V.E/BX
B40V.E/MB
B40V.E/RL

Corpo incasso_Concealed body_Corps encastré_Cuerpo empotrado_UP-Teil (pag. 209)

CW.1

Parti esterne_External parts_Parties externes_Parties externas_AP-Teile

B40V.XCW.E/MX

B40V.XCW.E/BX
B40V.XCW.E/MB
B40V.XCW.E/RL

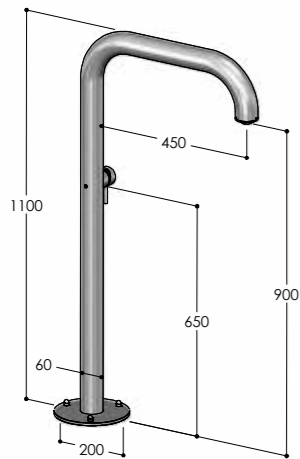
**B60V.HF.M**

Colonna High-Flow per vasca con miscelatore
High-Flow bathtub column with mixer
Colonne High-Flow pour baignoire avec mitigeur
Column de bañera High-Flow con monomando
High-Flow Badewannensäule mit Einhebelmischer

B60V.HF.M/MX

B60V.HF.M/BX
B60V.HF.M/MB
B60V.HF.M/RL

Corpo incasso_Concealed body_Corps encastré_Cuerpo empotrado_UP-Teil (pag. 209)

CW.2

Parti esterne_External parts_Parties externes_Parties externas_AP-Teile

B60V.HF.XCW.M/MX

B60V.HF.XCW.M/BX
B60V.HF.XCW.M/MB
B60V.HF.XCW.M/RL

B60V.HF.4S.M/MX

B60V.HF.4S.M/BX
B60V.HF.4S.M/MB
B60V.HF.4S.M/RL

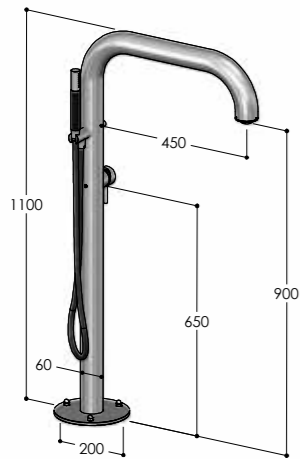
B60V.HF.ME 

Colonna High-Flow per vasca con miscelatore e doccia
High-Flow bathtub column with mixer and handshower
Colonne High-Flow pour baignoire avec mitigeur et douchette
Column de bañera High-Flow con monomando y teleducha
High-Flow Badewannensäule mit Einhebelmischer und Handbrause

B60V.HF.ME/MX

B60V.HF.ME/BX
B60V.HF.ME/MB
B60V.HF.ME/RL

Corpo incasso_Concealed body_Corps encastré_Cuerpo empotrado_UP-Teil (pag. 209)

CW.2

Parti esterne_External parts_Parties externes_Parties externas_AP-Teile

B60V.HF.XCW.ME/MX

B60V.HF.XCW.ME/BX
B60V.HF.XCW.ME/MB
B60V.HF.XCW.ME/RL

B60V.HF.4S.ME/MX

B60V.HF.4S.ME/BX
B60V.HF.4S.ME/MB
B60V.HF.4S.ME/RL

ST.CD

Rubinetto incasso
Concealed tap
Robinet d'arrêt encastrable
Llave de paso
UP-Ventil

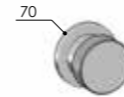

Corpo incasso_Concealed body_Corps encastré_Cuerpo empotrado_UP-Teil (pag. 209)

ST.INC

Parti esterne_External parts_Parties externes_Parties externas_AP-Teile

ST.CD/MX

ST.CD/BX
ST.CD/MB
ST.CD/RL
ST.CD/BB
ST.CD/BC
ST.CD/AB
ST.CD/DB

MR

Miscelatore da incasso per doccia
Concealed shower mixer
Mitigeur de douche à encastrer
Monomando de ducha mural
UP-Brausemischer

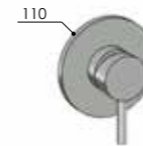

Corpo incasso_Concealed body_Corps encastré_Cuerpo empotrado_UP-Teil (pag. 209)

MR.INC

Parti esterne_External parts_Parties externes_Parties externas_AP-Teile

MR/MX

MR/BX
MR/MB
MR/RL
MR/BB
MR/BC
MR/AB
MR/DB

MR2.CD 

Miscelatore da incasso per doccia, con deviatore a 2 vie
Concealed shower mixer with 2-ways diverter
Mitigeur de douche encastrable avec inverseur à 2 voies
Monomando empotrado para ducha con desviador 2 salidas
UP-Brausemischer mit 2-Wege Umsteller

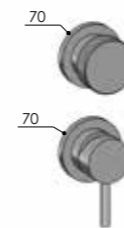

Corpo incasso_Concealed body_Corps encastré_Cuerpo empotrado_UP-Teil (pag. 209)

MR2.INC

Parti esterne_External parts_Parties externes_Parties externas_AP-Teile

MR2.CD/MX

MR2.CD/BX
MR2.CD/MB
MR2.CD/RL
MR2.CD/BB
MR2.CD/BC
MR2.CD/AB
MR2.CD/DB

MR3.CD 

Miscelatore da incasso per doccia, con deviatore a 3 vie
Concealed shower mixer with 3-ways diverter
Mitigeur de douche encastrable avec inverseur à 3 voies
Monomando empotrado para ducha con desviador 3 salidas
UP-Brausemischer mit 3-Wege Umsteller

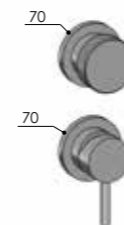

Corpo incasso_Concealed body_Corps encastré_Cuerpo empotrado_UP-Teil (pag. 209)

MR3.INC

Parti esterne_External parts_Parties externes_Parties externas_AP-Teile

MR3.CD/MX

MR3.CD/BX
MR3.CD/MB
MR3.CD/RL
MR3.CD/BB
MR3.CD/BC
MR3.CD/AB
MR3.CD/DB

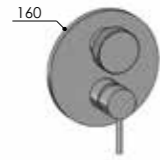

MX2.CD



Miscelatore da incasso per doccia, con deviatore a 2 vie
 Concealed shower mixer with 2-ways diverter
 Mitigeur de douche encastrable avec inverseur à 2 voies
 Monomando empotrado para ducha con desviador 2 salidas
 UP-Brausemischer mit 2-Wege Umsteller

Corpo incasso_Concealed body_Corps encastré_Cuerpo empotrado_UP-Teil (pag. 209)

MX.INC

Parti esterne_External parts_Parties externes_Parties externas_AP-Teile

MX2.CD/MX

- MX2.CD/BX
- MX2.CD/MB
- MX2.CD/RL
- MX2.CD/BB
- MX2.CD/BC
- MX2.CD/AB
- MX2.CD/DB

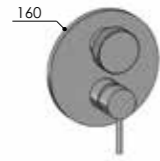

MX3.CD



Miscelatore da incasso per doccia, con deviatore a 3 vie
 Concealed shower mixer with 3-ways diverter
 Mitigeur de douche encastrable avec inverseur à 3 voies
 Monomando empotrado para ducha con desviador 3 salidas
 UP-Brausemischer mit 3-Wege Umsteller

Corpo incasso_Concealed body_Corps encastré_Cuerpo empotrado_UP-Teil (pag. 209)

MX.INC

Parti esterne_External parts_Parties externes_Parties externas_AP-Teile

MX3.CD/MX

- MX3.CD/BX
- MX3.CD/MB
- MX3.CD/RL
- MX3.CD/BB
- MX3.CD/BC
- MX3.CD/AB
- MX3.CD/DB

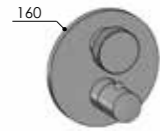

TC1.CD



Miscelatore termostatico da incasso per doccia
 Concealed thermostatic mixer for shower
 Mitigeur thermostatique de douche
 Mezclador termostatico empotrado para ducha
 UP-Thermostat-Brausemischer

Corpo incasso_Concealed body_Corps encastré_Cuerpo empotrado_UP-Teil (pag. 209)

MX.INC

Parti esterne_External parts_Parties externes_Parties externas_AP-Teile

TC1.CD/MX

- TC1.CD/BX
- TC1.CD/MB
- TC1.CD/RL
- TC1.CD/BB
- TC1.CD/BC
- TC1.CD/AB
- TC1.CD/DB

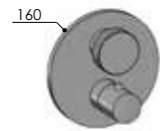

TC2.CD



Miscelatore termostatico da incasso per doccia, 2 vie
 Concealed thermostatic mixer for shower, 2-ways
 Mitigeur thermostatique de douche, 2-voies
 Mezclador termostatico empotrado para ducha, 2-salidas
 UP-Thermostat-Brausemischer, 2-Wege

Corpo incasso_Concealed body_Corps encastré_Cuerpo empotrado_UP-Teil (pag. 209)

MX.INC

Parti esterne_External parts_Parties externes_Parties externas_AP-Teile

TC2.CD/MX

- TC2.CD/BX
- TC2.CD/MB
- TC2.CD/RL
- TC2.CD/BB
- TC2.CD/BC
- TC2.CD/AB
- TC2.CD/DB

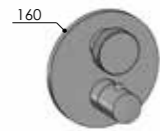

TC3.CD



Miscelatore termostatico da incasso per doccia, 3 vie
 Concealed thermostatic mixer for shower, 3-ways
 Mitigeur thermostatique de douche, 3-voies
 Mezclador termostatico empotrado para ducha, 3-salidas
 UP-Thermostat-Brausemischer, 3-Wege

Corpo incasso_Concealed body_Corps encastré_Cuerpo empotrado_UP-Teil (pag. 209)

MX.INC

Parti esterne_External parts_Parties externes_Parties externas_AP-Teile

TC3.CD/MX

- TC3.CD/BX
- TC3.CD/MB
- TC3.CD/RL
- TC3.CD/BB
- TC3.CD/BC
- TC3.CD/AB
- TC3.CD/DB

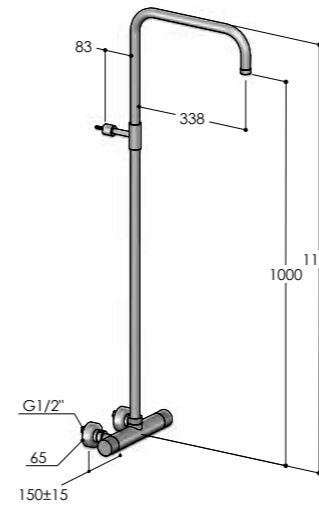

W344



Gruppo esterno con colonna doccia e soffione incassato
 Wall-mounted shower mixer, with column and concealed showerhead
 Mélangeur douche avec colonne et pomme de douche intégrée
 Batería para ducha con columna y rociador integrado
 AP-Brausebatterie mit Stange und integrierter Kopfbrause

W344/MX

- W344/BX
- W344/MB
- W344/RL
- W344/BB
- W344/BC
- W344/AB
- W344/DB

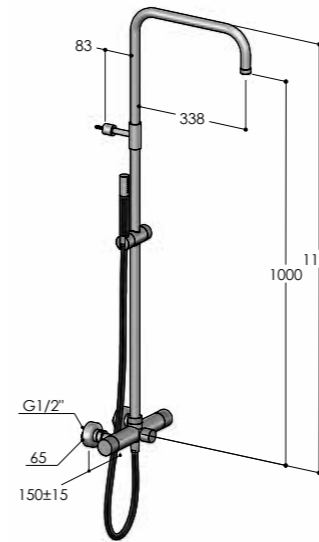

W344.E



Gruppo esterno con colonna doccia, soffione incassato e doccia
 Wall-mounted shower mixer, with column, concealed showerhead and handshower
 Mélangeur douche avec colonne, pomme de douche intégrée et douchette
 Batería para ducha con columna, rociador integrado y teleducha
 AP-Brausebatterie mit Stange, integrierter Kopfbrause und Handbrause

W344.E/MX

- W344.E/BX
- W344.E/MB
- W344.E/RL
- W344.E/BB
- W344.E/BC
- W344.E/AB
- W344.E/DB

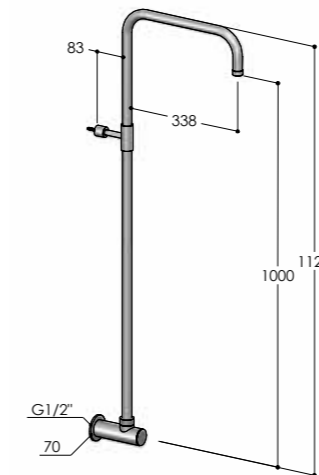

W3X7

Preso d'acqua con colonna doccia e soffione incassato
 Wall coupling, with column and concealed showerhead
 Coude de sortie, avec colonne et pomme de douche intégrée
 Codo mural, con columna y rociador integrado
 Wandanschlußbogen mit Stange und integrierter Kopfbrause

W3X7/MX

- W3X7/BX
- W3X7/MB
- W3X7/RL
- W3X7/BB
- W3X7/BC
- W3X7/AB
- W3X7/DB

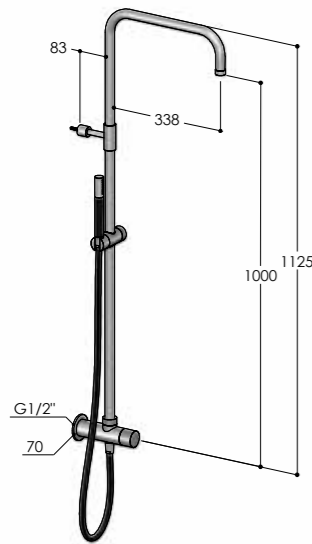
**W349.E**

Preso d'acqua con colonna doccia, soffione incassato e doccia

Wall coupling, with column, concealed showerhead and handshower

Coude de sortie, avec colonne, pomme de douche intégrée et douchette

Codo mural, con columna, rociador integrado y teleducha

Wandanschlußbogen mit Stange, integrierter Kopfbrause und Handbrause

W349.E/MX

W349.E/BX

W349.E/MB

W349.E/RL

W349.E/BB

W349.E/BC

W349.E/AB

W349.E/DB

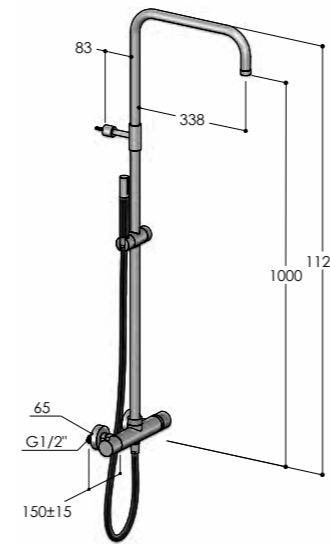
**W34A6.E**

Miscelatore termostatico esterno con colonna doccia, soffione incassato e doccia

Wall-mounted thermostatic mixer, with column, concealed showerhead and handshower

Mitigeur thermostatique mural avec colonne, pomme de douche intégrée et douchette

Mezclador termostatico mural con columna, rociador integrado y teleducha

AP-Thermostat-Brausemischer mit Stange, integrierter Kopfbrause und Handbrause

W34A6.E/MX

W34A6.E/BX

W34A6.E/MB

W34A6.E/RL

W34A6.E/BB

W34A6.E/BC

W34A6.E/AB

W34A6.E/DB

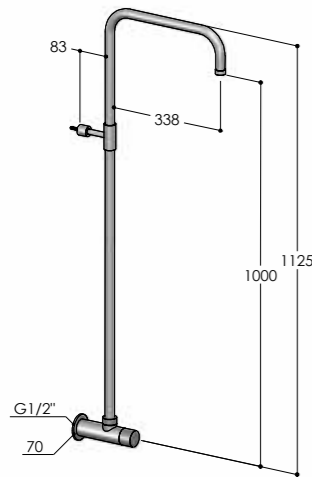
W347C

Rubinetto esterno con colonna doccia e soffione incassato

Wall-mounted tap with column and concealed showerhead

Robinet mural avec colonne et pomme de douche intégrée

Grifo mural con columna y rociador integrado

AP-Ventil mit Stange und integrierter Kopfbrause

W347C/MX

W347C/BX

W347C/MB

W347C/RL

W347C/BB

W347C/BC

W347C/AB

W347C/DB

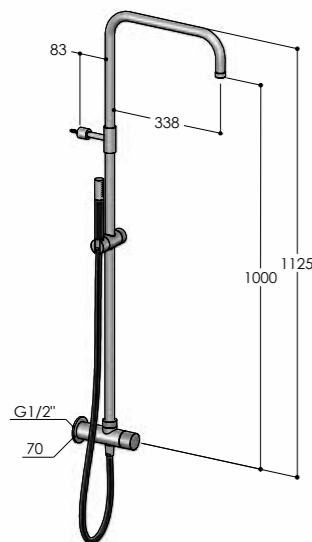
W349C.E

Rubinetto esterno con colonna doccia, soffione incassato e doccia

Wall-mounted tap with column, concealed showerhead and handshower

Robinet mural avec colonne, pomme de douche intégrée et douchette

Grifo mural con columna, rociador integrado y teleducha

AP-Ventil mit Stange, integrierter Kopfbrause und Handbrause

W349C.E/MX

W349C.E/BX

W349C.E/MB

W349C.E/RL

W349C.E/BB

W349C.E/BC

W349C.E/AB

W349C.E/DB

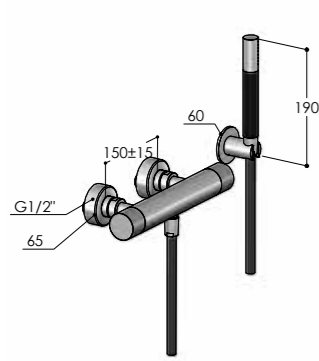
**WX44.SK**

Gruppo esterno con kit doccia
Wall-mounted mixer with shower kit
Mélangeur mural avec kit de douche
Bateria con kit de ducha mural
AP-Batterie mit Brausekit

WX44.SK/MX

WX44.SK/BX
WX44.SK/MB
WX44.SK/RL
WX44.SK/BB
WX44.SK/BC
WX44.SK/AB
WX44.SK/DB

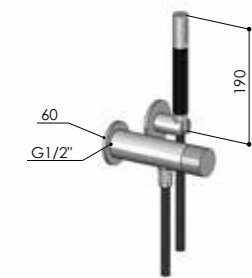
**WX47C.SK**

Rubinetto esterno con kit doccia
Wall-mounted tap with shower kit
Robinet mural avec kit de douche
Grifo mural con kit de ducha
AP-Ventil, mit Brausekit

WX47C.SK/MX

WX47C.SK/BX
WX47C.SK/MB
WX47C.SK/RL
WX47C.SK/BB
WX47C.SK/BC
WX47C.SK/AB
WX47C.SK/DB

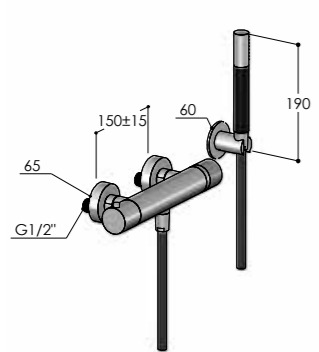
**WX4A6.SK**

Miscelatore termostatico esterno con kit doccia
Wall-mounted thermostatic mixer with shower kit
Mitigeur thermostatique mural avec kit de douche
Mezclador termostatico mural con kit de ducha
AP-Thermostat-Brausemischer mit Brausekit

WX4A6.SK/MX

WX4A6.SK/BX
WX4A6.SK/MB
WX4A6.SK/RL
WX4A6.SK/BB
WX4A6.SK/BC
WX4A6.SK/AB
WX4A6.SK/DB

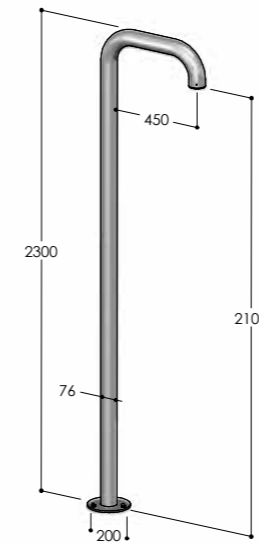
**B76.RC**

Colonna doccia con soffione incassato per comando remoto
Shower column with concealed showerhead for remote control
Colonne douche avec pomme de douche intégrée pour commande à distance
Columna de ducha con rociador integrado para control remoto
Duschsäule mit integrierter Kopfbrause für Fernsteuerung

B76.RC/MX

B76.RC/BX
B76.RC/MB
B76.RC/RL

Corpo incasso_Concealed body_Corps encastré_Cuerpo empotrado_UP-Teil (pag. 209)

CW.1

Parti esterne_External parts_Parties externes_Parties externas_AP-Teile

B76.XCW.RC/MX

B76.XCW.RC/BX
B76.XCW.RC/MB
B76.XCW.RC/RL

B76.EW.RC/MX

B76.EW.RC/BX
B76.EW.RC/MB
B76.EW.RC/RL

B76.4S.RC/MX

B76.4S.RC/BX
B76.4S.RC/MB
B76.4S.RC/RL

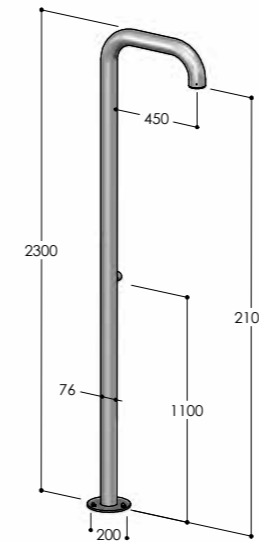
**B76**

Colonna doccia con rubinetto d'arresto e soffione incassato
Shower column with stop tap and concealed showerhead
Colonne douche avec robinet d'arrêt et pomme de douche intégrée
Columna de ducha con grifo y rociador integrado
Duschsäule mit Wasserhahn und integrierter Kopfbrause

B76/MX

B76/BX
B76/MB
B76/RL

Corpo incasso_Concealed body_Corps encastré_Cuerpo empotrado_UP-Teil (pag. 209)

CW.1

Parti esterne_External parts_Parties externes_Parties externas_AP-Teile

B76.XCW/MX

B76.XCW/BX
B76.XCW/MB
B76.XCW/RL

B76.EW/MX

B76.EW/BX
B76.EW/MB
B76.EW/RL

B76.4S/MX

B76.4S/BX
B76.4S/MB
B76.4S/RL

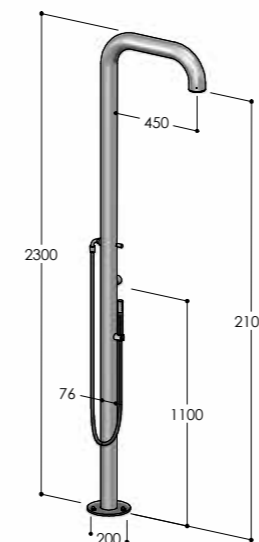
**B76.E**

Colonna doccia con rubinetto d'arresto, soffione incassato e doccia
Shower column with stop tap, concealed showerhead and handshower
Colonne douche avec robinet d'arrêt, pomme de douche intégrée et douchette
Columna de ducha con grifo, rociador integrado y teleducha
Duschsäule mit Wasserhahn, integrierter Kopfbrause und Handbrause

B76.E/MX

B76.E/BX
B76.E/MB
B76.E/RL

Corpo incasso_Concealed body_Corps encastré_Cuerpo empotrado_UP-Teil (pag. 209)

CW.1

Parti esterne_External parts_Parties externes_Parties externas_AP-Teile

B76.XCW.E/MX

B76.XCW.E/BX
B76.XCW.E/MB
B76.XCW.E/RL

B76.EW.E/MX

B76.EW.E/BX
B76.EW.E/MB
B76.EW.E/RL

B76.4S.E/MX

B76.4S.E/BX
B76.4S.E/MB
B76.4S.E/RL

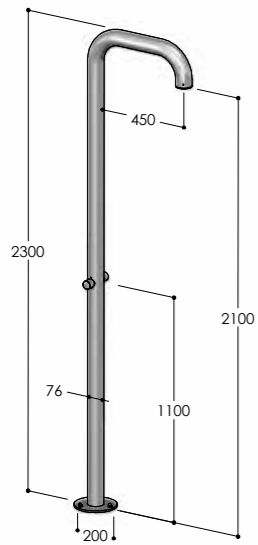

B76.2



Colonna doccia con 2 rubinetti d'arresto e soffione incassato
 Shower column with 2 stop taps and concealed showerhead
 Colonne douche avec 2 robinets d'arrêt et pomme de douche intégrée
 Columna de ducha con 2 grifos y rociador integrado
 Duschsäule mit 2 Wasserhähnen und integrierter Kopfbrause

B76.2/MX
B76.2/BX
B76.2/MB
B76.2/RL
Corpo incasso_Concealed body_Corps encastré_Cuerpo empotrado_UP-Teil (pag. 209)
CW.2
Parti esterne_External parts_Parties externes_Parties externas_AP-Teile
B76.XCW.2/MX
B76.XCW.2/BX
B76.XCW.2/MB
B76.XCW.2/RL
B76.EW.2/MX
B76.EW.2/BX
B76.EW.2/MB
B76.EW.2/RL
B76.4S.2/MX
B76.4S.2/BX
B76.4S.2/MB
B76.4S.2/RL

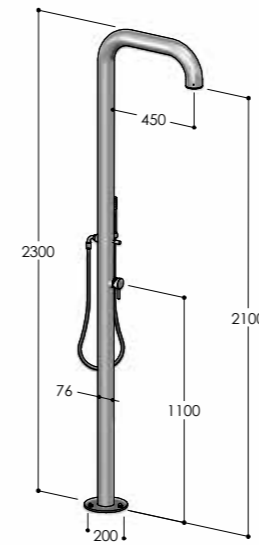

B76.ME



Colonna doccia con miscelatore, soffione incassato e doccia
 Shower column with mixer, concealed showerhead and handshower
 Colonne douche avec mitigeur, pomme de douche intégrée et douchette
 Columna de ducha con monomando, rociador integrado y teleducha
 Duschsäule mit Einhebelmischer, integrierter Kopfbrause und Handbrause

B76.ME/MX
B76.ME/BX
B76.ME/MB
B76.ME/RL
Corpo incasso_Concealed body_Corps encastré_Cuerpo empotrado_UP-Teil (pag. 209)
CW.2
Parti esterne_External parts_Parties externes_Parties externas_AP-Teile
B76.XCW.ME/MX
B76.XCW.ME/BX
B76.XCW.ME/MB
B76.XCW.ME/RL
B76.EW.ME/MX
B76.EW.ME/BX
B76.EW.ME/MB
B76.EW.ME/RL
B76.4S.ME/MX
B76.4S.ME/BX
B76.4S.ME/MB
B76.4S.ME/RL

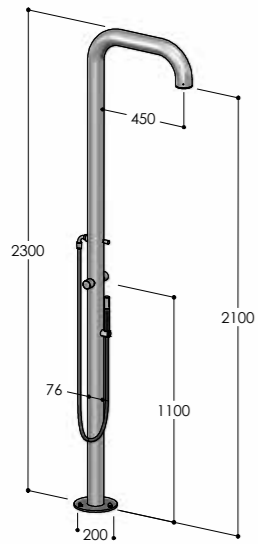

B76.2E



Colonna doccia con 2 rubinetti d'arresto, soffione incassato e doccia
 Shower column with 2 stop taps, concealed showerhead and handshower
 Colonne douche avec 2 robinets d'arrêt, pomme de douche intégrée et douchette
 Columna de ducha con 2 grifos, rociador integrado y teleducha
 Duschsäule mit 2 Wasserhähnen, integrierter Kopfbrause und Handbrause

B76.2E/MX
B76.2E/BX
B76.2E/MB
B76.2E/RL
Corpo incasso_Concealed body_Corps encastré_Cuerpo empotrado_UP-Teil (pag. 209)
CW.2
Parti esterne_External parts_Parties externes_Parties externas_AP-Teile
B76.XCW.2E/MX
B76.XCW.2E/BX
B76.XCW.2E/MB
B76.XCW.2E/RL
B76.EW.2E/MX
B76.EW.2E/BX
B76.EW.2E/MB
B76.EW.2E/RL
B76.4S.2E/MX
B76.4S.2E/BX
B76.4S.2E/MB
B76.4S.2E/RL

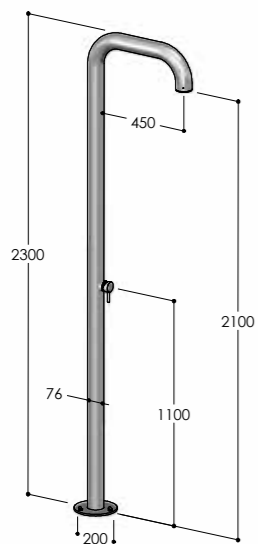

B76.M



Colonna doccia con miscelatore e soffione incassato
 Shower column with mixer and concealed showerhead
 Colonne douche avec mitigeur et pomme de douche intégrée
 Columna de ducha con monomando y rociador integrado
 Duschsäule mit Einhebelmischer und integrierter Kopfbrause

B76.M/MX
B76.M/BX
B76.M/MB
B76.M/RL
Corpo incasso_Concealed body_Corps encastré_Cuerpo empotrado_UP-Teil (pag. 209)
CW.2
Parti esterne_External parts_Parties externes_Parties externas_AP-Teile
B76.XCW.M/MX
B76.XCW.M/BX
B76.XCW.M/MB
B76.XCW.M/RL
B76.EW.M/MX
B76.EW.M/BX
B76.EW.M/MB
B76.EW.M/RL
B76.4S.M/MX
B76.4S.M/BX
B76.4S.M/MB
B76.4S.M/RL



BOSS WIDE

Shower

pag. 90



BOSS WIDE

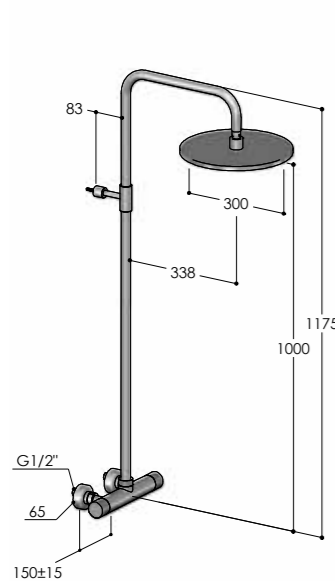

W444



Gruppo esterno con colonna doccia e soffione S10
 Wall-mounted shower mixer, with column and showerhead S10
 Mélangeur douche avec colonne et pomme de douche S10
 Batería para ducha con columna y rociador S10
 AP-Brausebatterie mit Stange und Kopfbrause S10

W444/MX

- W444/BX
- W444/MB
- W444/RL
- W444/BB
- W444/BC
- W444/AB
- W444/DB

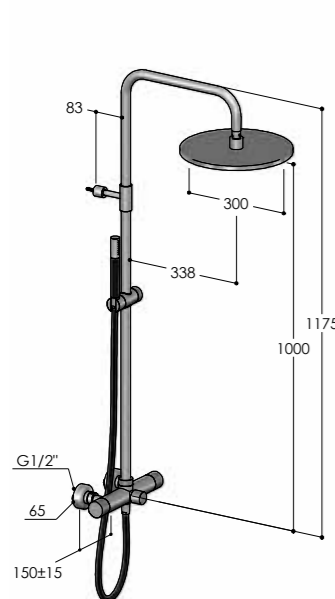

W444.E



Gruppo esterno con colonna doccia, soffione S10 e doccia
 Wall-mounted shower mixer, with column, showerhead S10 and handshower
 Mélangeur douche avec colonne, pomme de douche S10 et douchette
 Batería para ducha con columna, rociador S10 y teleducha
 AP-Brausebatterie mit Stange, Kopfbrause S10 und Handbrause

W444.E/MX

- W444.E/BX
- W444.E/MB
- W444.E/RL
- W444.E/BB
- W444.E/BC
- W444.E/AB
- W444.E/DB

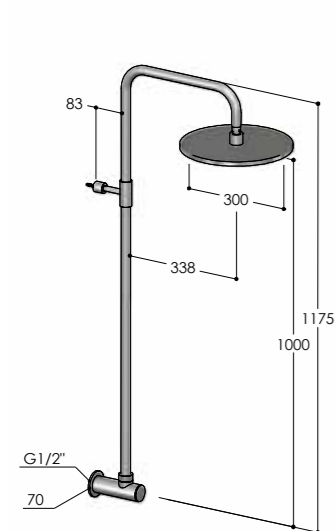

W4X7

Preso d'acqua con colonna doccia e soffione S10
 Wall coupling, with column and showerhead S10
 Coude de sortie, avec colonne et pomme de douche S10
 Codo mural, con columna y rociador S10
 Wandanschlußbogen mit Stange und Kopfbrause S10

W4X7/MX

- W4X7/BX
- W4X7/MB
- W4X7/RL
- W4X7/BB
- W4X7/BC
- W4X7/AB
- W4X7/DB

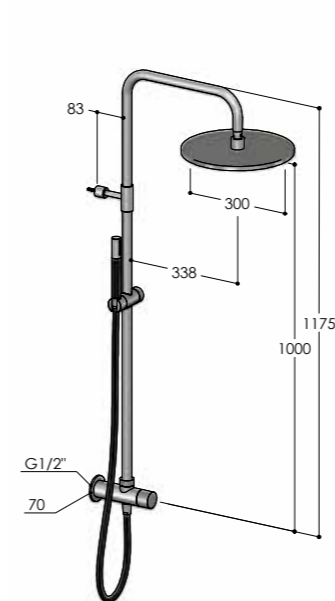

W449.E



Preso d'acqua con colonna doccia, soffione S10 e doccia
 Wall coupling, with column, showerhead S10 and handshower
 Coude de sortie, avec colonne, pomme de douche S10 et douchette
 Codo mural, con columna, rociador S10 y teleducha
 Wandanschlußbogen mit Stange, Kopfbrause S10 und Handbrause

W449.E/MX

- W449.E/BX
- W449.E/MB
- W449.E/RL
- W449.E/BB
- W449.E/BC
- W449.E/AB
- W449.E/DB

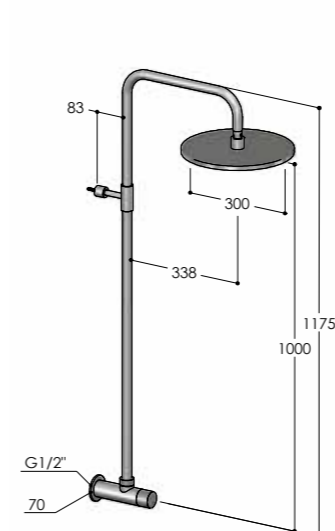

W447C



Rubinetto esterno con colonna doccia e soffione S10
 Wall-mounted tap with column and showerhead S10
 Robinet mural avec colonne et pomme de douche S10
 Grifo mural con columna y rociador S10
 AP-Ventil mit Stange und Kopfbrause S10

W447C/MX

- W447C/BX
- W447C/MB
- W447C/RL
- W447C/BB
- W447C/BC
- W447C/AB
- W447C/DB

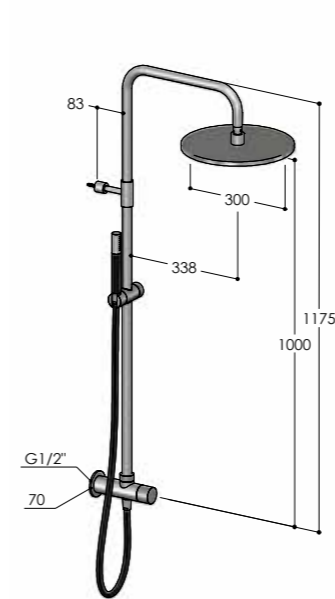

W449C.E



Rubinetto esterno con colonna doccia, soffione S10 e doccia
 Wall-mounted tap with column, showerhead S10 and handshower
 Robinet mural avec colonne, pomme de douche S10 et douchette
 Grifo mural con columna, rociador S10 y teleducha
 AP-Ventil mit Stange, Kopfbrause S10 und Handbrause

W449C.E/MX

- W449C.E/BX
- W449C.E/MB
- W449C.E/RL
- W449C.E/BB
- W449C.E/BC
- W449C.E/AB
- W449C.E/DB

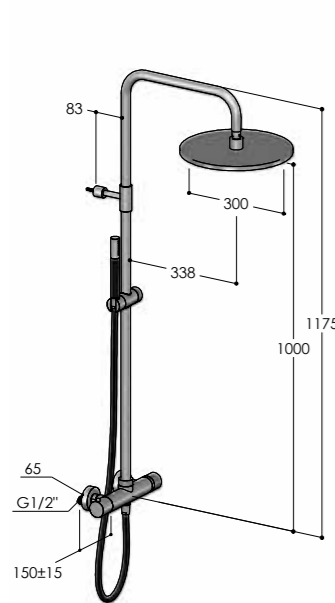

W44A6.E



Miscelatore termostatico esterno con colonna doccia, soffione S10 e doccetta
 Wall-mounted thermostatic mixer, with column, showerhead S10 and handshower
 Mitigeur thermostatique mural avec colonne, pomme de douche S10 et douchette
 Mezclador termostatico mural con columna, rociador S10 y teleducha
 AP-Thermostat-Brausemischer mit Stange, Kopfbrause S10 und Handbrause

W44A6.E/MX

- W44A6.E/BX
- W44A6.E/MB
- W44A6.E/RL
- W44A6.E/BB
- W44A6.E/BC
- W44A6.E/AB
- W44A6.E/DB

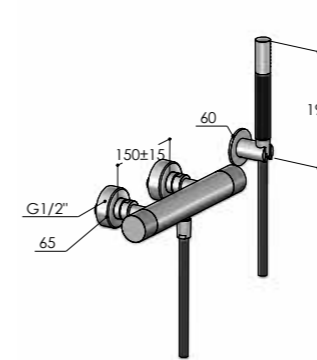

WX44.SK



Gruppo esterno con kit doccia
 Wall-mounted mixer with shower kit
 Mélangeur mural avec kit de douche
 Batería con kit de ducha mural
 AP-Batterie mit Brausekit

WX44.SK/MX

- WX44.SK/BX
- WX44.SK/MB
- WX44.SK/RL
- WX44.SK/BB
- WX44.SK/BC
- WX44.SK/AB
- WX44.SK/DB

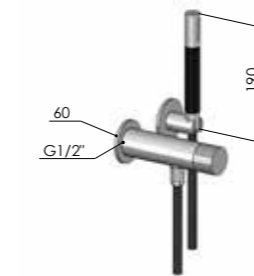

WX47C.SK



Rubinetto esterno con kit doccia
 Wall-mounted tap with shower kit
 Robinet mural avec kit de douche
 Grifo mural con kit de ducha
 AP-Ventil, mit Brausekit

WX47C.SK/MX

- WX47C.SK/BX
- WX47C.SK/MB
- WX47C.SK/RL
- WX47C.SK/BB
- WX47C.SK/BC
- WX47C.SK/AB
- WX47C.SK/DB

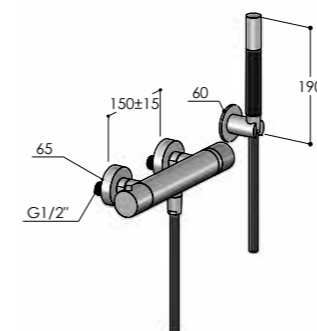

WX4A6.SK



Miscelatore termostatico esterno con kit doccia
 Wall-mounted thermostatic mixer with shower kit
 Mitigeur thermostatique mural avec kit de douche
 Mezclador termostatico mural con kit de ducha
 AP-Thermostat-Brausemischer mit Brausekit

WX4A6.SK/MX

- WX4A6.SK/BX
- WX4A6.SK/MB
- WX4A6.SK/RL
- WX4A6.SK/BB
- WX4A6.SK/BC
- WX4A6.SK/AB
- WX4A6.SK/DB

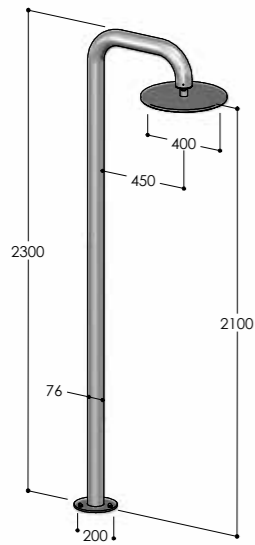

BW76.RC

Colonna doccia con soffione S12 per comando remoto
 Shower column with showerhead S12 for remote control
 Colonne douche avec pomme de douche S12 pour commande à distance
 Columna de ducha con rociador S12 para control remoto
 Duschsäule mit Kopfbrause S12 für Fernsteuerung

✓	BW76.RC/MX BW76.RC/BX BW76.RC/MB BW76.RC/RL
	Corpo incasso_Concealed body_Corps encastré_Cuerpo empotrado_UP-Teil (pag. 209)
	CW.1
CW	Parti esterne_External parts_Parties externes_Parties externas_AP-Teile BW76.XCW.RC/MX BW76.XCW.RC/BX BW76.XCW.RC/MB BW76.XCW.RC/RL
EW	BW76.EW.RC/MX BW76.EW.RC/BX BW76.EW.RC/MB BW76.EW.RC/RL
4S	BW76.4S.RC/MX BW76.4S.RC/BX BW76.4S.RC/MB BW76.4S.RC/RL

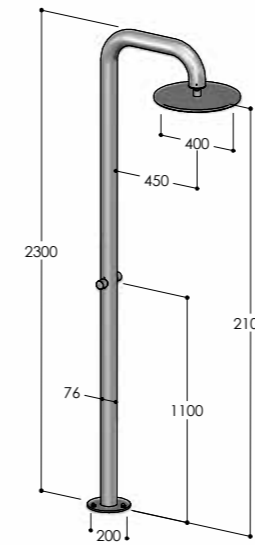

BW76.2

Colonna doccia con 2 rubinetti d'arresto e soffione S12
 Shower column with 2 stop taps and showerhead S12
 Colonne douche avec 2 robinets d'arrêt et pomme de douche S12
 Columna de ducha con 2 grifos y rociador S12
 Duschsäule mit 2 Wasserhähnen und Kopfbrause S12

✓	BW76.2/MX BW76.2/BX BW76.2/MB BW76.2/RL
	Corpo incasso_Concealed body_Corps encastré_Cuerpo empotrado_UP-Teil (pag. 209)
	CW.2
CW	Parti esterne_External parts_Parties externes_Parties externas_AP-Teile BW76.XCW.2/MX BW76.XCW.2/BX BW76.XCW.2/MB BW76.XCW.2/RL
EW	BW76.EW.2/MX BW76.EW.2/BX BW76.EW.2/MB BW76.EW.2/RL
4S	BW76.4S.2/MX BW76.4S.2/BX BW76.4S.2/MB BW76.4S.2/RL

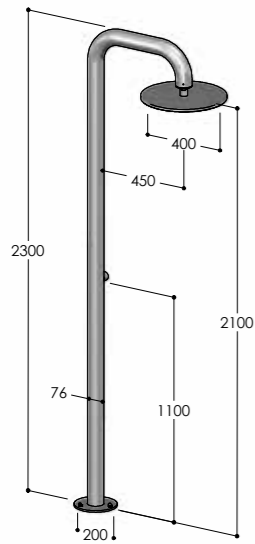

BW76

Colonna doccia con rubinetto d'arresto e soffione S12
 Shower column with stop tap and showerhead S12
 Colonne douche avec robinet d'arrêt et pomme de douche S12
 Columna de ducha con grifo y rociador S12
 Duschsäule mit Wasserhahn und Kopfbrause S12

✓	BW76/MX BW76/BX BW76/MB BW76/RL
	Corpo incasso_Concealed body_Corps encastré_Cuerpo empotrado_UP-Teil (pag. 209)
	CW.1
CW	Parti esterne_External parts_Parties externes_Parties externas_AP-Teile BW76.XCW/MX BW76.XCW/BX BW76.XCW/MB BW76.XCW/RL
EW	BW76.EW/MX BW76.EW/BX BW76.EW/MB BW76.EW/RL
4S	BW76.4S/MX BW76.4S/BX BW76.4S/MB BW76.4S/RL

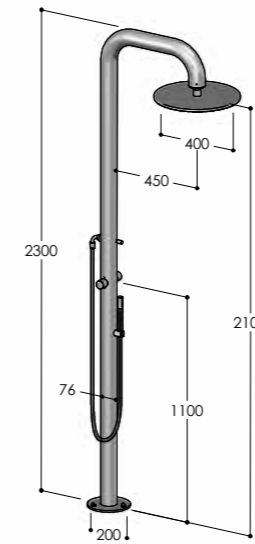

BW76.2E

Colonna doccia con 2 rubinetti d'arresto, soffione S12 e doccia
 Shower column with 2 stop taps, showerhead S12 and handshower
 Colonne douche avec 2 robinets d'arrêt, pomme de douche S12 et douchette
 Columna de ducha con 2 grifos, rociador S12 y teleducha
 Duschsäule mit 2 Wasserhähnen, Kopfbrause S12 und Handbrause

✓	BW76.2E/MX BW76.2E/BX BW76.2E/MB BW76.2E/RL
	Corpo incasso_Concealed body_Corps encastré_Cuerpo empotrado_UP-Teil (pag. 209)
	CW.2
CW	Parti esterne_External parts_Parties externes_Parties externas_AP-Teile BW76.XCW.2E/MX BW76.XCW.2E/BX BW76.XCW.2E/MB BW76.XCW.2E/RL
EW	BW76.EW.2E/MX BW76.EW.2E/BX BW76.EW.2E/MB BW76.EW.2E/RL
4S	BW76.4S.2E/MX BW76.4S.2E/BX BW76.4S.2E/MB BW76.4S.2E/RL

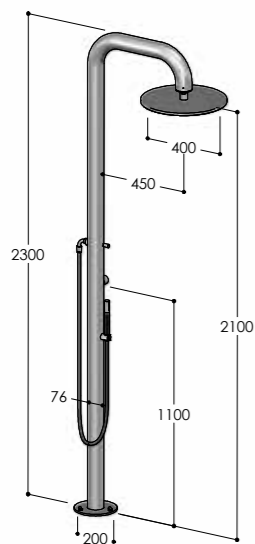

BW76.E

Colonna doccia con rubinetto d'arresto, soffione S12 e doccia
 Shower column with stop tap, showerhead S12 and handshower
 Colonne douche avec robinet d'arrêt, pomme de douche S12 et douchette
 Columna de ducha con grifo, rociador S12 y teleducha
 Duschsäule mit Wasserhahn, Kopfbrause S12 und Handbrause

✓	BW76.E/MX BW76.E/BX BW76.E/MB BW76.E/RL
	Corpo incasso_Concealed body_Corps encastré_Cuerpo empotrado_UP-Teil (pag. 209)
	CW.1
CW	Parti esterne_External parts_Parties externes_Parties externas_AP-Teile BW76.XCW.E/MX BW76.XCW.E/BX BW76.XCW.E/MB BW76.XCW.E/RL
EW	BW76.EW.E/MX BW76.EW.E/BX BW76.EW.E/MB BW76.EW.E/RL
4S	BW76.4S.E/MX BW76.4S.E/BX BW76.4S.E/MB BW76.4S.E/RL

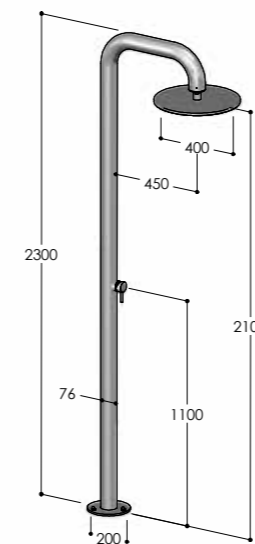

BW76.M

Colonna doccia con miscelatore e soffione S12
 Shower column with mixer and showerhead S12
 Colonne douche avec mitigeur et pomme de douche S12
 Columna de ducha con monomando y rociador S12
 Duschsäule mit Einhebelmischer und Kopfbrause S12

✓	BW76.M/MX BW76.M/BX BW76.M/MB BW76.M/RL
	Corpo incasso_Concealed body_Corps encastré_Cuerpo empotrado_UP-Teil (pag. 209)
	CW.2
CW	Parti esterne_External parts_Parties externes_Parties externas_AP-Teile BW76.XCW.M/MX BW76.XCW.M/BX BW76.XCW.M/MB BW76.XCW.M/RL
EW	BW76.EW.M/MX BW76.EW.M/BX BW76.EW.M/MB BW76.EW.M/RL
4S	BW76.4S.M/MX BW76.4S.M/BX BW76.4S.M/MB BW76.4S.M/RL

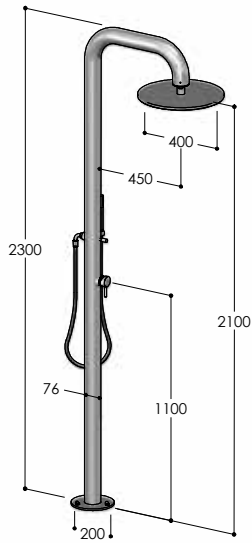

BW76.ME



Colonna doccia con miscelatore, soffione S12 e doccia

Shower column with mixer, showerhead S12 and handshower

Colonne douche avec mitigeur, pomme de douche S12 et douchette

Column de ducha con monomando, rociador S12 y teleducha

Duschsäule mit Einhebelmischer, Kopfbrause S12 und Handbrause

✓	BW76.ME/MX BW76.ME/BX BW76.ME/MB BW76.ME/RL
	Corpo incasso_Concealed body_Corps encastré_Cuerpo empotrado_UP-Teil (pag. 209) CW.2 Parti esterne_External parts_Parties externes_Parties externas_AP-Teile CW BW76.XCW.ME/MX BW76.XCW.ME/BX BW76.XCW.ME/MB BW76.XCW.ME/RL
EW	BW76.EW.ME/MX BW76.EW.ME/BX BW76.EW.ME/MB BW76.EW.ME/RL
4S	BW76.4S.ME/MX BW76.4S.ME/BX BW76.4S.ME/MB BW76.4S.ME/RL



ORIGO

Basin	<i>pag. 98</i>
Bathtub	<i>pag. 102</i>
Shower	<i>pag. 107</i>



ORIGO

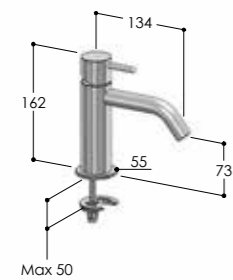

W40

Miscelatore da lavabo
Washbasin mixer
Mitigeur de lavabo
Monomando de lavabo
Waschtischmischer

W40/MX

- W40/BX
- W40/MB
- W40/RL
- W40/BB
- W40/BC
- W40/AB
- W40/DB



W2M.O

Miscelatore da bordo lavabo
Deck-mounted washbasin mixer
Mitigeur de lavabo, montage sur gorge
Monomando para borde de lavabo
Waschtisch-Batterie für Randmontage

W2M.O/MX

- W2M.O/BX
- W2M.O/MB
- W2M.O/RL
- W2M.O/BB
- W2M.O/BC
- W2M.O/AB
- W2M.O/DB

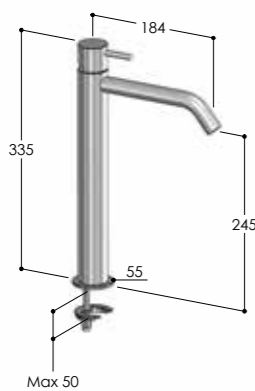

W40H

Miscelatore alto da lavabo
Washbasin pillar mixer
Mitigeur haut de lavabo
Monomando de lavabo alto
Waschtischmischer hoch

W40H/MX

- W40H/BX
- W40H/MB
- W40H/RL
- W40H/BB
- W40H/BC
- W40H/AB
- W40H/DB

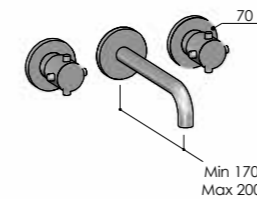

W3P.O

Batteria lavabo da incasso
Concealed washbasin set
Mélangeur lavabo à encastrer
Bateria mural de lavabo
Wandmontierte-Waschtisch-Batterie

Corpo incasso_Concealed body_Corps encastré_Cuerpo empotrado_UP-Teil (pag. 209)

W3P.INC

Parti externe_External parts_Parties externes_Parties externas_AP-Teile

W3P.O/MX

- W3P.O/BX
- W3P.O/MB
- W3P.O/RL
- W3P.O/BB
- W3P.O/BC
- W3P.O/AB
- W3P.O/DB

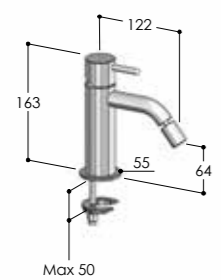

W40B

Miscelatore da bidet
Bidet mixer
Mitigeur de bidet
Monomando de bidet
Bidetmischer

W40B/MX

- W40B/BX
- W40B/MB
- W40B/RL
- W40B/BB
- W40B/BC
- W40B/AB
- W40B/DB

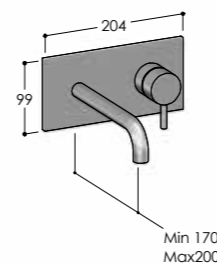

W2MP.O

Miscelatore lavabo da incasso
Concealed washbasin mixer
Mitigeur lavabo à encastrer
Monomando mural de lavabo
UP-Waschtisch-Einhandbatterie

Corpo incasso_Concealed body_Corps encastré_Cuerpo empotrado_UP-Teil (pag. 209)

W2MP.INC

Parti externe_External parts_Parties externes_Parties externas_AP-Teile

W2MP.O/MX

- W2MP.O/BX
- W2MP.O/MB
- W2MP.O/RL
- W2MP.O/BB
- W2MP.O/BC
- W2MP.O/AB
- W2MP.O/DB



W3.O

Batteria da lavabo 3 fori
Basin set 3-holes
Mélangeur de lavabo 3 trous
Bateria para lavabo 3 agujeros
3-Loch Waschtischbatterie

W3.O/MX

- W3.O/BX
- W3.O/MB
- W3.O/RL
- W3.O/BB
- W3.O/BC
- W3.O/AB
- W3.O/DB

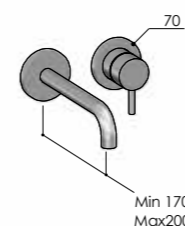

W2MP.2.O

Miscelatore lavabo da incasso
Concealed washbasin mixer
Mitigeur lavabo à encastrer
Monomando mural de lavabo
UP-Waschtisch-Einhandbatterie

Corpo incasso_Concealed body_Corps encastré_Cuerpo empotrado_UP-Teil (pag. 209)

W2MP.INC

Parti externe_External parts_Parties externes_Parties externas_AP-Teile

W2MP.2.O/MX

- W2MP.2.O/BX
- W2MP.2.O/MB
- W2MP.2.O/RL
- W2MP.2.O/BB
- W2MP.2.O/BC
- W2MP.2.O/AB
- W2MP.2.O/DB



WMRL



Miscelatore da incasso per lavabo
 Concealed mixer for washbasin
 Mitiguer encastrable pour lavabo
 Monomando empotrado para lavabo
 Waschtischmischer

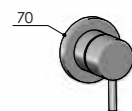

Corpo incasso_Concealed body_Corps encastré_Cuerpo empotrado_UP-Teil (pag. 209)

MR.INC

Parti esterne_External parts_Parties externes_Parties externas_AP-Teile

WMRL/MX

- WMRL/BX
- WMRL/MB
- WMRL/RL
- WMRL/BB
- WMRL/BC
- WMRL/AB
- WMRL/DB

SP.O

Bocca a parete
 Wall-mounted spout
 Bec déverseur
 Caño mural
 Wandmontierter Wanneneinlauf

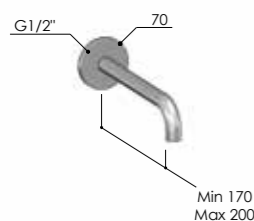

SP.O/MX

- SP.O/BX
- SP.O/MB
- SP.O/RL
- SP.O/BB
- SP.O/BC
- SP.O/AB
- SP.O/DB



C40L.RC

Colonna per lavabo per comando remoto
 Washbasin column for remote control
 Colonne pour lavabo pour commande à distance
 Column de lavabo para control remoto
 Waschtischsäule für Fernsteuerung

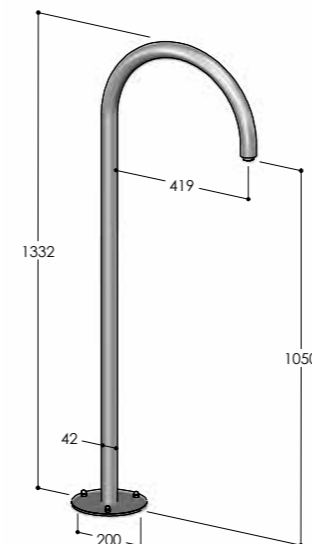

C40L.RC/MX

- C40L.RC/BX
- C40L.RC/MB
- C40L.RC/RL

Corpo incasso_Concealed body_Corps encastré_Cuerpo empotrado_UP-Teil (pag. 209)

CW.1

Parti esterne_External parts_Parties externes_Parties externas_AP-Teile

CW

- C40L.XCW.RC/MX**
- C40L.XCW.RC/BX
- C40L.XCW.RC/MB
- C40L.XCW.RC/RL

C40L



Colonna per lavabo con rubinetto d'arresto
 Washbasin column with stop tap
 Colonne pour lavabo avec robinet d'arrêt
 Column de lavabo con grifo
 Waschtischsäule mit Wasserhahn

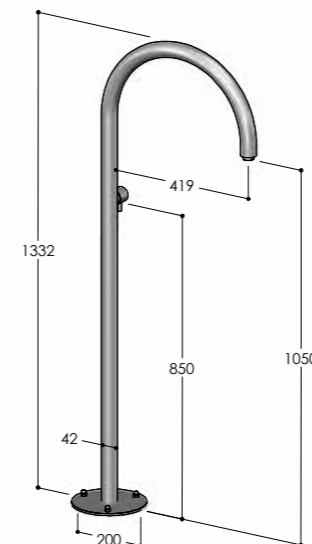

C40L/MX

- C40L/BX
- C40L/MB
- C40L/RL

Corpo incasso_Concealed body_Corps encastré_Cuerpo empotrado_UP-Teil (pag. 209)

CW.1

Parti esterne_External parts_Parties externes_Parties externas_AP-Teile

CW

- C40L.XCW/MX**
- C40L.XCW/BX
- C40L.XCW/MB
- C40L.XCW/RL

C40L.M



Colonna per lavabo con miscelatore
 Washbasin column with mixer
 Colonne pour lavabo avec mitigeur
 Column de lavabo con monomando
 Waschtischsäule mit Einhebelmischer

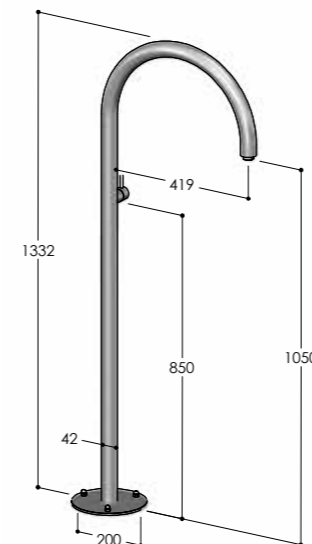

C40L.M/MX

- C40L.M/BX
- C40L.M/MB
- C40L.M/RL

Corpo incasso_Concealed body_Corps encastré_Cuerpo empotrado_UP-Teil (pag. 209)

CW.2

Parti esterne_External parts_Parties externes_Parties externas_AP-Teile

CW

- C40L.XCW.M/MX**
- C40L.XCW.M/BX
- C40L.XCW.M/MB
- C40L.XCW.M/RL



W3B.O

Batteria bordo vasca 3 fori
Bathtub set 3-holes
Mélangeur de baignoire pour montage sur gorge, 5 trous
Bateria para borde de bañera, 3 agujeros
3-Loch Badewannenbatterie für Randmontage

W3B.O/MX

- W3B.O/BX
- W3B.O/MB
- W3B.O/RL
- W3B.O/BB
- W3B.O/BC
- W3B.O/AB
- W3B.O/DB



W5B.O

Batteria bordo vasca 5 fori
Bathtub set 5-holes
Mélangeur de baignoire pour montage sur gorge, 5 trous
Bateria para borde de bañera, 5 agujeros
5-Loch Badewannenbatterie für Randmontage

W5B.O/MX

- W5B.O/BX
- W5B.O/MB
- W5B.O/RL
- W5B.O/BB
- W5B.O/BC
- W5B.O/AB
- W5B.O/DB



W2MB.O

Miscelatore per bordo vasca
Deck-mounted bathtub mixer
Mitigeur de baignoire pour montage sur gorge
Monomando de repisa para bañera
Badewannenmischer für Randmontage

W2MB.O/MX

- W2MB.O/BX
- W2MB.O/MB
- W2MB.O/RL
- W2MB.O/BB
- W2MB.O/BC
- W2MB.O/AB
- W2MB.O/DB

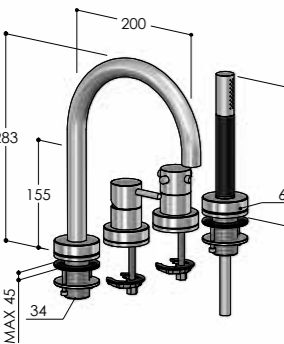

W4MB.O

Miscelatore per bordo vasca con doccia
Deck-mounted bathtub mixer with handshower
Mitigeur de baignoire pour montage sur gorge avec douche
Monomando de repisa para bañera con teleducha
Badewannenmischer für Randmontage mit Handbrause

W4MB.O/MX

- W4MB.O/BX
- W4MB.O/MB
- W4MB.O/RL
- W4MB.O/BB
- W4MB.O/BC
- W4MB.O/AB
- W4MB.O/DB

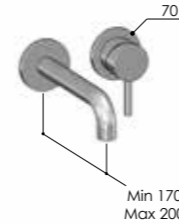

W2MBP.O

Miscelatore bordo vasca da incasso
Concealed bathtub mixer
Mélangeur pour baignoire encastrable
Monomando empotrado de bañera
UP-Badewannenmischer

Corpo incasso_Concealed body_Corps encastré_Cuerpo empotrado_UP-Teil (pag. 209)

W2MP.INC

Parti esterne_External parts_Parties externes_Parties externas_AP-Teile

W2MBP.O/MX

- W2MBP.O/BX
- W2MBP.O/MB
- W2MBP.O/RL
- W2MBP.O/BB
- W2MBP.O/BC
- W2MBP.O/AB
- W2MBP.O/DB

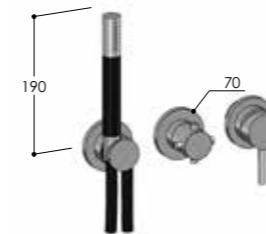

W3MBP.O

Miscelatore bordo vasca da incasso con doccia
Concealed bathtub mixer with handshower
Mélangeur pour baignoire encastrable avec douche
Monomando empotrado de bañera con teleducha
UP-Badewannenmischer mit Handbrause

Corpo incasso_Concealed body_Corps encastré_Cuerpo empotrado_UP-Teil (pag. 209)

W3MP.INC

Parti esterne_External parts_Parties externes_Parties externas_AP-Teile

W3MBP.O/MX

- W3MBP.O/BX
- W3MBP.O/MB
- W3MBP.O/RL
- W3MBP.O/BB
- W3MBP.O/BC
- W3MBP.O/AB
- W3MBP.O/DB

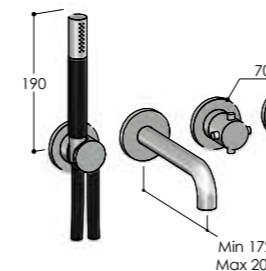

W4MBP.O

Miscelatore bordo vasca da incasso con doccia
Concealed bathtub mixer with handshower
Mélangeur pour baignoire encastrable avec douche
Monomando empotrado de bañera con teleducha
UP-Badewannenmischer mit Handbrause

Corpo incasso_Concealed body_Corps encastré_Cuerpo empotrado_UP-Teil (pag. 209)

W4MP.INC

Parti esterne_External parts_Parties externes_Parties externas_AP-Teile

W4MBP.O/MX

- W4MBP.O/BX
- W4MBP.O/MB
- W4MBP.O/RL
- W4MBP.O/BB
- W4MBP.O/BC
- W4MBP.O/AB
- W4MBP.O/DB

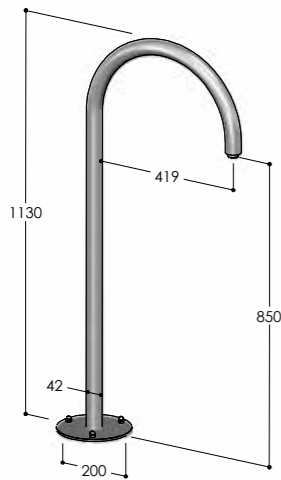

C40V.RC

Colonna per vasca per comando remoto
Bathtub column for remote control
Colonne pour baignoire pour commande à distance
Columna de bañera para control remoto
Badewannensäule für Fernsteuerung

✓	C40V.RC/MX C40V.RC/BX C40V.RC/MB C40V.RC/RL
	Corpo incasso_Concealed body_Corps encastré_Cuerpo empotrado_UP-Teil (pag. 209)
	CW.1
CW	Parti esterne_External parts_Parties externes_Parties externas_AP-Teile C40V.XCW.RC/MX C40V.XCW.RC/BX C40V.XCW.RC/MB C40V.XCW.RC/RL

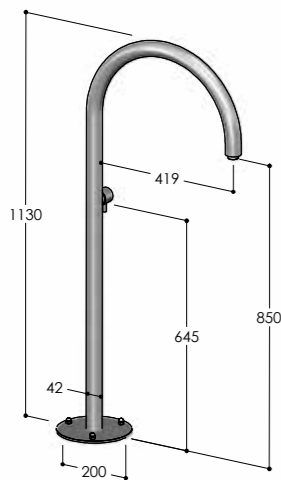

C40V

Colonna per vasca con rubinetto d'arresto
Bathtub column with stop tap
Colonne pour baignoire avec robinet d'arrêt
Columna de bañera con grifo
Badewannensäule mit Wasserhahn

✓	C40V/MX C40V/BX C40V/MB C40V/RL
	Corpo incasso_Concealed body_Corps encastré_Cuerpo empotrado_UP-Teil (pag. 209)
	CW.1
CW	Parti esterne_External parts_Parties externes_Parties externas_AP-Teile C40V.XCW/MX C40V.XCW/BX C40V.XCW/MB C40V.XCW/RL

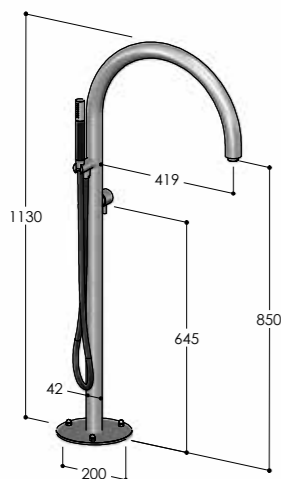

C40V.E

Colonna per vasca con rubinetto d'arresto e doccia
Bathtub column with stop tap and handshower
Colonne pour baignoire avec robinet d'arrêt et douche
Columna de bañera con grifo y teleducha
Badewannensäule mit Wasserhahn und Handbrause

✓	C40V.E/MX C40V.E/BX C40V.E/MB C40V.E/RL
	Corpo incasso_Concealed body_Corps encastré_Cuerpo empotrado_UP-Teil (pag. 209)
	CW.1
CW	Parti esterne_External parts_Parties externes_Parties externas_AP-Teile C40V.XCW.E/MX C40V.XCW.E/BX C40V.XCW.E/MB C40V.XCW.E/RL

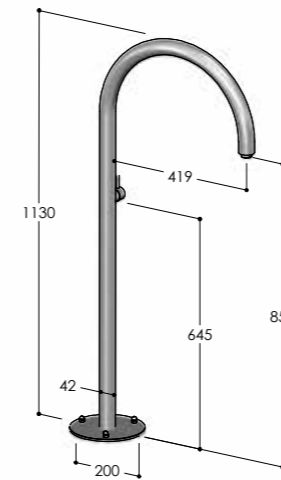

C40V.M

Colonna per vasca con miscelatore
Bathtub column with mixer
Colonne pour baignoire avec mitigeur
Columna de bañera con monomando
Badewannensäule mit Einhebelmischer

✓	C40V.M/MX C40V.M/BX C40V.M/MB C40V.M/RL
	Corpo incasso_Concealed body_Corps encastré_Cuerpo empotrado_UP-Teil (pag. 209)
	CW.2
CW	Parti esterne_External parts_Parties externes_Parties externas_AP-Teile C40V.XCW.M/MX C40V.XCW.M/BX C40V.XCW.M/MB C40V.XCW.M/RL

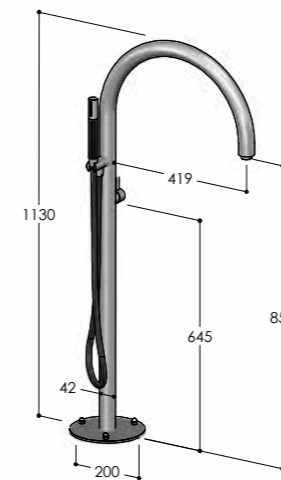

C40V.ME

Colonna per vasca con miscelatore e doccia
Bathtub column with mixer and handshower
Colonne pour baignoire avec mitigeur et douche
Columna de bañera con monomando y teleducha
Badewannensäule mit Einhebelmischer und Handbrause

✓	C40V.ME/MX C40V.ME/BX C40V.ME/MB C40V.ME/RL
	Corpo incasso_Concealed body_Corps encastré_Cuerpo empotrado_UP-Teil (pag. 209)
	CW.2
CW	Parti esterne_External parts_Parties externes_Parties externas_AP-Teile C40V.XCW.ME/MX C40V.XCW.ME/BX C40V.XCW.ME/MB C40V.XCW.ME/RL

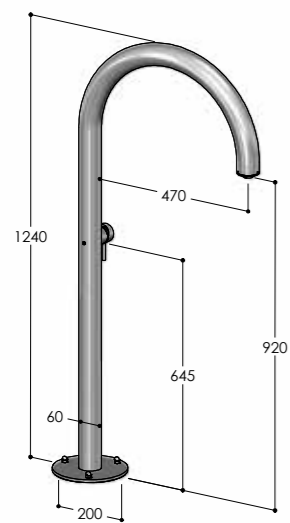

C60V.HF.M

Colonna High-Flow per vasca con miscelatore
High-Flow bathtub column with mixer
Colonne High-Flow pour baignoire avec mitigeur
Column de bañera High-Flow con monomando
High-Flow Badewannensäule mit Einhebelmischer

✓	C60V.HF.M/MX C60V.HF.M/BX C60V.HF.M/MB C60V.HF.M/RL
	Corpo incasso_Concealed body_Corps encastré_Cuerpo empotrado_UP-Teil (pag. 209) CW.2
CW	Parti esterne_External parts_Parties externes_Parties externas_AP-Teile C60V.HF.XCW.M/MX C60V.HF.XCW.M/BX C60V.HF.XCW.M/MB C60V.HF.XCW.M/RL
4S	C60V.HF.4S.M/MX C60V.HF.4S.M/BX C60V.HF.4S.M/MB C60V.HF.4S.M/RL

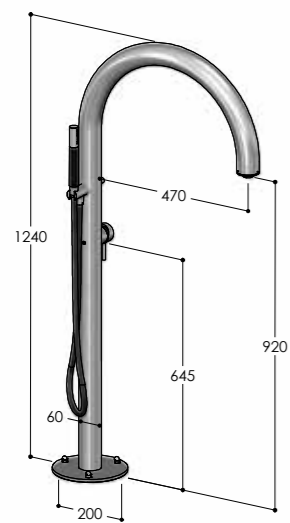

C60V.HF.ME

Colonna High-Flow per vasca con miscelatore e doccia
High-Flow bathtub column with mixer and handshower
Colonne High-Flow pour baignoire avec mitigeur et douchette
Column de bañera High-Flow con monomando y teleducha
High-Flow Badewannensäule mit Einhebelmischer und Handbrause

✓	C60V.HF.ME/MX C60V.HF.ME/BX C60V.HF.ME/MB C60V.HF.ME/RL
	Corpo incasso_Concealed body_Corps encastré_Cuerpo empotrado_UP-Teil (pag. 209) CW.2
CW	Parti esterne_External parts_Parties externes_Parties externas_AP-Teile C60V.HF.XCW.ME/MX C60V.HF.XCW.ME/BX C60V.HF.XCW.ME/MB C60V.HF.XCW.ME/RL
4S	C60V.HF.4S.ME/MX C60V.HF.4S.ME/BX C60V.HF.4S.ME/MB C60V.HF.4S.ME/RL

ST.O

Rubinetto incasso
Concealed tap
Robinet d'arrêt encastrable
Llave de paso
UP-Ventil

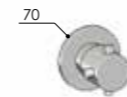

Corpo incasso_Concealed body_Corps encastré_Cuerpo empotrado_UP-Teil (pag. 209)
ST.INC

Parti esterne_External parts_Parties externes_Parties externas_AP-Teile

ST.O/MX
ST.O/BX
ST.O/MB
ST.O/RL
ST.O/BB
ST.O/BC
ST.O/AB
ST.O/DB

MR

Miscelatore da incasso per doccia
Concealed shower mixer
Mitigeur de douche à encastrer
Monomando de ducha mural
UP-Brausemischer

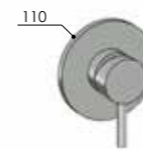

Corpo incasso_Concealed body_Corps encastré_Cuerpo empotrado_UP-Teil (pag. 209)
MR.INC

Parti esterne_External parts_Parties externes_Parties externas_AP-Teile

MR/MX
MR/BX
MR/MB
MR/RL
MR/BB
MR/BC
MR/AB
MR/DB

MR2.O

Miscelatore da incasso per doccia, con deviatore a 2 vie
Concealed shower mixer with 2-ways diverter
Mitigeur de douche encastrable avec inverseur à 2 voies
Monomando empotrado para ducha con desviador 2 salidas
UP-Brausemischer mit 2-Wege Umsteller

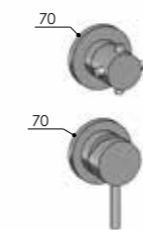

Corpo incasso_Concealed body_Corps encastré_Cuerpo empotrado_UP-Teil (pag. 209)
MR2.INC

Parti esterne_External parts_Parties externes_Parties externas_AP-Teile

MR2.O/MX
MR2.O/BX
MR2.O/MB
MR2.O/RL
MR2.O/BB
MR2.O/BC
MR2.O/AB
MR2.O/DB

MR3.O

Miscelatore da incasso per doccia, con deviatore a 3 vie
Concealed shower mixer with 3-ways diverter
Mitigeur de douche encastrable avec inverseur à 3 voies
Monomando empotrado para ducha con desviador 3 salidas
UP-Brausemischer mit 3-Wege Umsteller

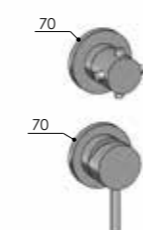

Corpo incasso_Concealed body_Corps encastré_Cuerpo empotrado_UP-Teil (pag. 209)
MR3.INC

Parti esterne_External parts_Parties externes_Parties externas_AP-Teile

MR3.O/MX
MR3.O/BX
MR3.O/MB
MR3.O/RL
MR3.O/BB
MR3.O/BC
MR3.O/AB
MR3.O/DB

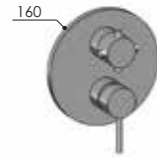

MX2.O



Miscelatore da incasso per doccia, con deviatore a 2 vie
 Concealed shower mixer with 2-ways diverter
 Mitigeur de douche encastrable avec inverseur à 2 voies
 Monomando empotrado para ducha con desviador 2 salidas
 UP-Brausemischer mit 2-Wege Umsteller

Corpo incasso_Concealed body_Corps encastré_Cuerpo empotrado_UP-Teil (pag. 209)

MX.INC

Parti esterne_External parts_Parties externes_Parties externas_AP-Teile

MX2.O/MX

- MX2.O/BX
- MX2.O/MB
- MX2.O/RL
- MX2.O/BB
- MX2.O/BC
- MX2.O/AB
- MX2.O/DB

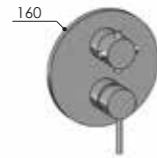

MX3.O



Miscelatore da incasso per doccia, con deviatore a 3 vie
 Concealed shower mixer with 3-ways diverter
 Mitigeur de douche encastrable avec inverseur à 3 voies
 Monomando empotrado para ducha con desviador 3 salidas
 UP-Brausemischer mit 3-Wege Umsteller

Corpo incasso_Concealed body_Corps encastré_Cuerpo empotrado_UP-Teil (pag. 209)

MX.INC

Parti esterne_External parts_Parties externes_Parties externas_AP-Teile

MX3.O/MX

- MX3.O/BX
- MX3.O/MB
- MX3.O/RL
- MX3.O/BB
- MX3.O/BC
- MX3.O/AB
- MX3.O/DB

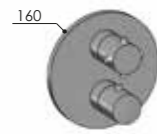

TC1.O



Miscelatore termostatico da incasso per doccia
 Concealed thermostatic mixer for shower
 Mitigeur thermostatique de douche
 Mezclador termostatico empotrado para ducha
 UP-Thermostat-Brausemischer

Corpo incasso_Concealed body_Corps encastré_Cuerpo empotrado_UP-Teil (pag. 209)

MX.INC

Parti esterne_External parts_Parties externes_Parties externas_AP-Teile

TC1.O/MX

- TC1.O/BX
- TC1.O/MB
- TC1.O/RL
- TC1.O/BB
- TC1.O/BC
- TC1.O/AB
- TC1.O/DB

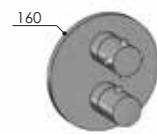

TC2.O



Miscelatore termostatico da incasso per doccia, 2 vie
 Concealed thermostatic mixer for shower, 2-ways
 Mitigeur thermostatique de douche, 2-voies
 Mezclador termostatico empotrado para ducha, 2-salidas
 UP-Thermostat-Brausemischer, 2-Wege

Corpo incasso_Concealed body_Corps encastré_Cuerpo empotrado_UP-Teil (pag. 209)

MX.INC

Parti esterne_External parts_Parties externes_Parties externas_AP-Teile

TC2.O/MX

- TC2.O/BX
- TC2.O/MB
- TC2.O/RL
- TC2.O/BB
- TC2.O/BC
- TC2.O/AB
- TC2.O/DB

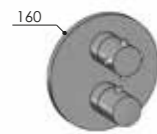

TC3.O



Miscelatore termostatico da incasso per doccia, 3 vie
 Concealed thermostatic mixer for shower, 3-ways
 Mitigeur thermostatique de douche, 3-voies
 Mezclador termostatico empotrado para ducha, 3-salidas
 UP-Thermostat-Brausemischer, 3-Wege

Corpo incasso_Concealed body_Corps encastré_Cuerpo empotrado_UP-Teil (pag. 209)

MX.INC

Parti esterne_External parts_Parties externes_Parties externas_AP-Teile

TC3.O/MX

- TC3.O/BX
- TC3.O/MB
- TC3.O/RL
- TC3.O/BB
- TC3.O/BC
- TC3.O/AB
- TC3.O/DB

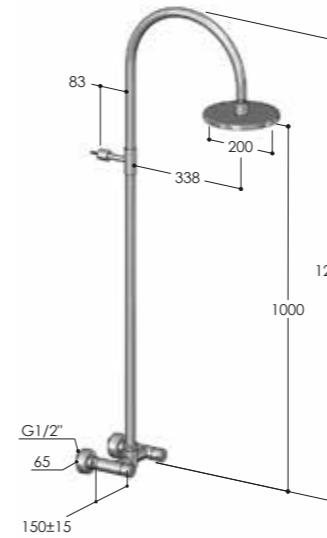

W920



Gruppo esterno con colonna doccia e soffione S06
 Wall-mounted shower mixer, with column and showerhead S06
 Mélangeur douche avec colonne et pomme de douche S06
 Batería para ducha con columna y rociador S06
 AP-Brausebatterie mit Stange und Kopfbrause S06

W920/MX

- W920/BX
- W920/MB
- W920/RL
- W920/BB
- W920/BC
- W920/AB
- W920/DB

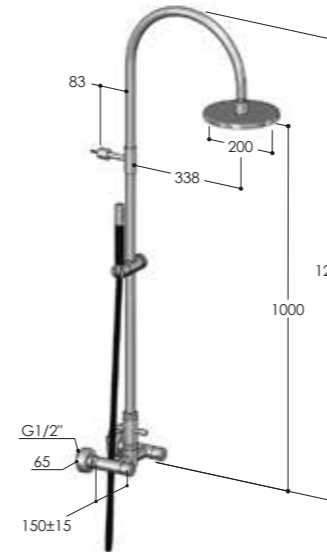

W920.E



Gruppo esterno con colonna doccia, soffione S06 e doccia
 Wall-mounted shower mixer, with column, showerhead S06 and handshower
 Mélangeur douche avec colonne, pomme de douche S06 et douchette
 Batería para ducha con columna rociador S06 y teleducha
 AP-Brausebatterie mit Stange, Kopfbrause S06 und Handbrause

W920.E/MX

- W920.E/BX
- W920.E/MB
- W920.E/RL
- W920.E/BB
- W920.E/BC
- W920.E/AB
- W920.E/DB

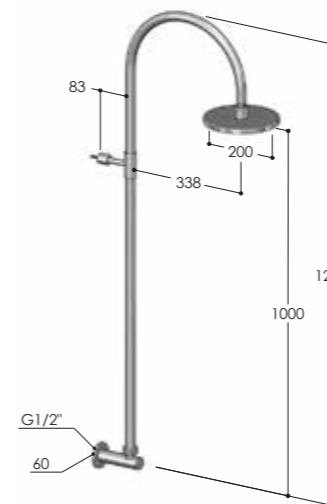

W9X1

Preso d'acqua con colonna doccia e soffione S06
 Wall coupling, with column and showerhead S06
 Coude de sortie, avec colonne et pomme de douche S06
 Codo mural, con columna y rociador S06
 Wandanschlußbogen mit Stange und Kopfbrause S06

W9X1/MX

- W9X1/BX
- W9X1/MB
- W9X1/RL
- W9X1/BB
- W9X1/BC
- W9X1/AB
- W9X1/DB

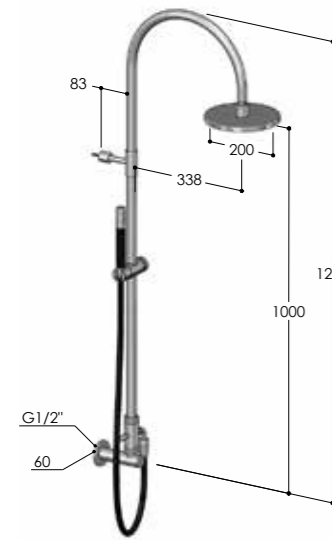

W9X1.E

Presad'acqua con colonna doccia, soffione S06 e doccia
 Wall coupling, with column, showerhead S06 and handshower
 Coude de sortie, avec colonne, pomme de douche S06 et douchette
 Codo mural, con columna, rociador S06 y teleducha
 Wandanschlußbogen mit Stange, Kopfbrause S06 und Handbrause



- W9X1.E/MX**
 W9X1.E/BX
 W9X1.E/MB
 W9X1.E/RL
 W9X1.E/BB
 W9X1.E/BC
 W9X1.E/AB
 W9X1.E/DB

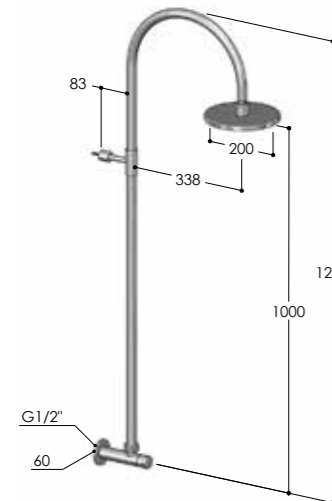

W922

Rubinetto esterno con colonna doccia e soffione S06
 Wall-mounted tap with column and showerhead S06
 Robinet mural avec colonne et pomme de douche S06
 Grifo mural con columna y rociador S06
 AP-Ventil mit Stange und Kopfbrause S06

- W922/MX**
 W922/BX
 W922/MB
 W922/RL
 W922/BB
 W922/BC
 W922/AB
 W922/DB

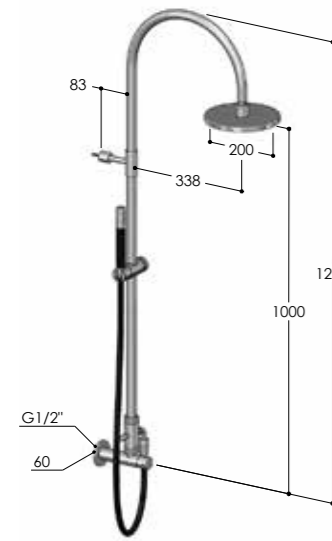

W922.E

Rubinetto esterno con colonna doccia, soffione S06 e doccia
 Wall-mounted tap with column, showerhead S06 and handshower
 Robinet mural avec colonne, pomme de douche S06 et douchette
 Grifo mural con columna, rociador S06 y teleducha
 AP-Ventil mit Stange, Kopfbrause S06 und Handbrause



- W922.E/MX**
 W922.E/BX
 W922.E/MB
 W922.E/RL
 W922.E/BB
 W922.E/BC
 W922.E/AB
 W922.E/DB

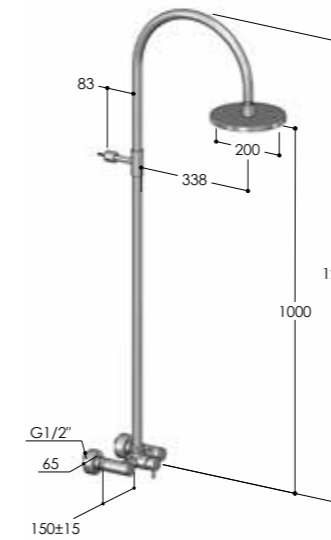

W983

Miscelatore esterno con colonna doccia e soffione S06
 Wall-mounted mixer, with column and showerhead S06
 Mitigeur mural avec colonne et pomme de douche S06
 Mezclador mural con columna y rociador S06
 AP-Brausemischer mit Stange und Kopfbrause S06

- W983/MX**
 W983/BX
 W983/MB
 W983/RL
 W983/BB
 W983/BC
 W983/AB
 W983/DB

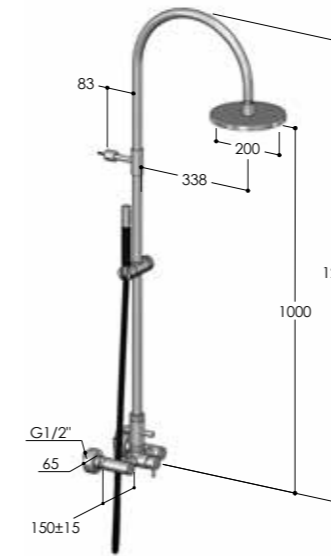

W983.E

Miscelatore esterno con colonna doccia, soffione S06 e doccia
 Wall-mounted mixer, with column, showerhead S06 and handshower
 Mitigeur mural avec colonne, pomme de douche S06 et douchette
 Mezclador mural con columna, rociador S06 y teleducha
 AP-Brausemischer mit Stange, Kopfbrause S06 und Handbrause



- W983.E/MX**
 W983.E/BX
 W983.E/MB
 W983.E/RL
 W983.E/BB
 W983.E/BC
 W983.E/AB
 W983.E/DB

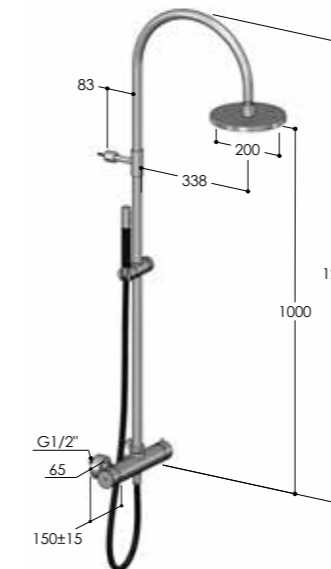

W975.E

Miscelatore termostatico esterno con colonna doccia, soffione S06 e doccia
 Wall-mounted thermostatic mixer, with column, showerhead S06 and handshower
 Mitigeur thermostatique mural avec colonne, pomme de douche S06 et douchette
 Mezclador termostatico mural con columna, rociador S06 y teleducha
 AP-Thermostat-Brausemischer mit Stange, Kopfbrause S06 und Handbrause



- W975.E/MX**
 W975.E/BX
 W975.E/MB
 W975.E/RL
 W975.E/BB
 W975.E/BC
 W975.E/AB
 W975.E/DB

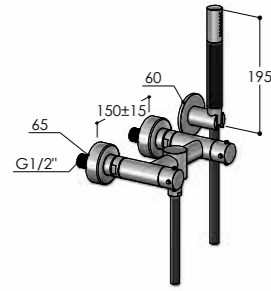

WX20.SK

Gruppo esterno con kit doccia
Wall-mounted mixer with shower kit
Mélangeur mural avec kit de douche
Bateria con kit de ducha mural
AP-Batterie mit Brausekit

WX20.SK/MX

- WX20.SK/BX
- WX20.SK/MB
- WX20.SK/RL
- WX20.SK/BB
- WX20.SK/BC
- WX20.SK/AB
- WX20.SK/DB

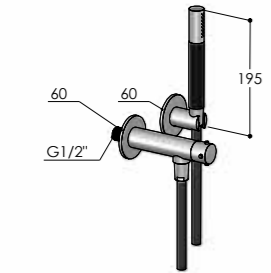

WX22.SK

Rubinetto esterno con kit doccia
Wall-mounted tap with shower kit
Robinet mural avec kit de douche
Grifo mural con kit de ducha
AP-Ventil, mit Brausekit

WX22.SK/MX

- WX22.SK/BX
- WX22.SK/MB
- WX22.SK/RL
- WX22.SK/BB
- WX22.SK/BC
- WX22.SK/AB
- WX22.SK/DB

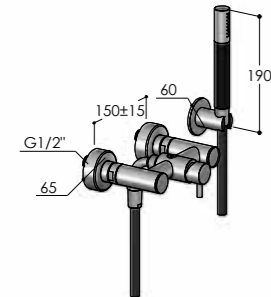

WX83.SK

Miscelatore esterno con kit doccia
Wall-mounted mixer with shower kit
Mitigeur mural avec kit de douche
Mezclador mural con kit de ducha
AP-Brausemischer mit Brausekit

WX83.SK/MX

- WX83.SK/BX
- WX83.SK/MB
- WX83.SK/RL
- WX83.SK/BB
- WX83.SK/BC
- WX83.SK/AB
- WX83.SK/DB

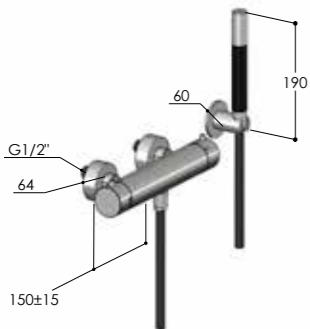

WX75.SK

Miscelatore termostatico esterno con kit doccia
Wall-mounted thermostatic mixer with shower kit
Mitigeur thermostatique mural avec kit de douche
Mezclador termostatic mural con kit de ducha
AP-Thermostat-Brausemischer mit Brausekit

WX75.SK/MX

- WX75.SK/BX
- WX75.SK/MB
- WX75.SK/RL
- WX75.SK/BB
- WX75.SK/BC
- WX75.SK/AB
- WX75.SK/DB

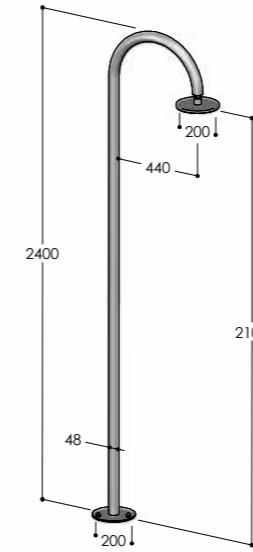

C50AS.RC

Colonna doccia con soffione S06 per comando remoto
Shower column with S06 showerhead for remote control
Colonne douche avec pomme de douche S06 pour commande à distance
Columna de ducha con rociador S06 para control remoto
Duschsäule mit Kopfbrause S06 für Fernsteuerung

- C50AS.RC/MX**
- C50AS.RC/BX
- C50AS.RC/MB
- C50AS.RC/RL
- Corpo incasso_Concealed body_Corps encastré_Cuerpo empotrado_UP-Teil (pag. 209)
- CW.1**
- Parti esterne_External parts_Parties externes_Parties externas_AP-Teile
- CW**
- C50AS.XCW.RC/MX**
- C50AS.XCW.RC/BX
- C50AS.XCW.RC/MB
- C50AS.XCW.RC/RL
- C50AS.EW.RC/MX**
- C50AS.EW.RC/BX
- C50AS.EW.RC/MB
- C50AS.EW.RC/RL

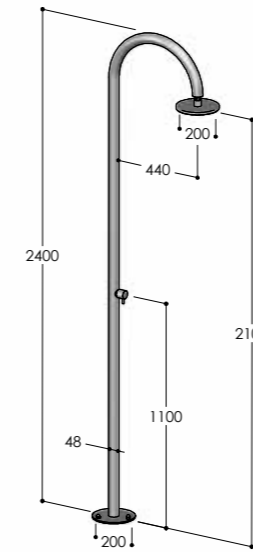

C50AS

Colonna doccia con rubinetto d'arresto e soffione S06
Shower column with stop tap and S06 showerhead
Colonne douche avec robinet d'arrêt et pomme de douche S06
Columna de ducha con grifo y rociador S06
Duschsäule mit Wasserhahn und Kopfbrause S06

- C50AS/MX**
- C50AS/BX
- C50AS/MB
- C50AS/RL
- Corpo incasso_Concealed body_Corps encastré_Cuerpo empotrado_UP-Teil (pag. 209)
- CW.1**
- Parti esterne_External parts_Parties externes_Parties externas_AP-Teile
- CW**
- C50AS.XCW/MX**
- C50AS.XCW/BX
- C50AS.XCW/MB
- C50AS.XCW/RL
- C50AS.EW/MX**
- C50AS.EW/BX
- C50AS.EW/MB
- C50AS.EW/RL

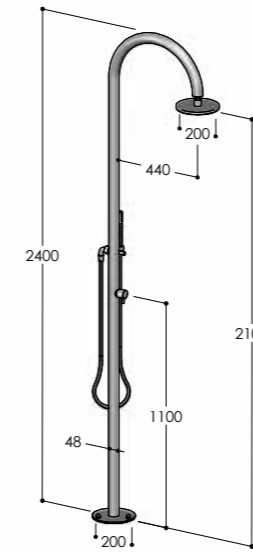

C50AS.E

Colonna doccia con rubinetto d'arresto, soffione S06 e doccia
Shower column with stop tap, S06 showerhead and handshower
Colonne douche avec robinet d'arrêt, pomme de douche S06 et douchette
Columna de ducha con grifo, rociador S06 y teleducha
Duschsäule mit Wasserhahn, Kopfbrause S06 und Handbrause

- C50AS.E/MX**
- C50AS.E/BX
- C50AS.E/MB
- C50AS.E/RL
- Corpo incasso_Concealed body_Corps encastré_Cuerpo empotrado_UP-Teil (pag. 209)
- CW.1**
- Parti esterne_External parts_Parties externes_Parties externas_AP-Teile
- CW**
- C50AS.XCW.E/MX**
- C50AS.XCW.E/BX
- C50AS.XCW.E/MB
- C50AS.XCW.E/RL
- C50AS.EW.E/MX**
- C50AS.EW.E/BX
- C50AS.EW.E/MB
- C50AS.EW.E/RL

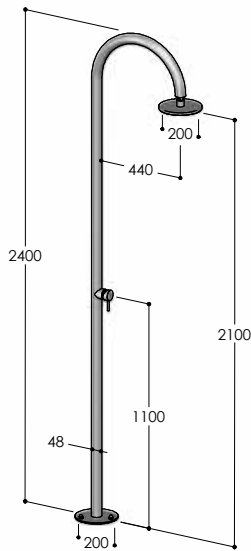

C50AS.M

Colonna doccia con miscelatore e soffione S06
 Shower column with mixer and showerhead S06
 Colonne douche avec mitigeur et pomme de douche S06
 Columna de ducha con monomando y rociador S06
 Duschsäule mit Einhebelmischer und Kopfbrause S06

✓	C50AS.M/MX
	C50AS.M/BX
	C50AS.M/MB
	C50AS.M/RL
CW	Corpo incasso_Concealed body_Corps encastré_Cuerpo empotrado_UP-Teil (pag. 209)
	CW.1
	Parti esterne_External parts_Parties externes_Parties externas_AP-Teile
	C50AS.XCW.M/MX
	C50AS.XCW.M/BX
	C50AS.XCW.M/MB
	C50AS.XCW.M/RL
EW	C50AS.EW.M/MX
	C50AS.EW.M/BX
	C50AS.EW.M/MB
	C50AS.EW.M/RL

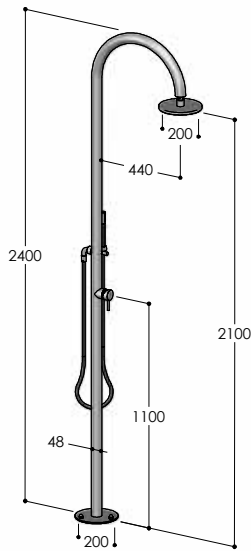

C50AS.ME

Colonna doccia con miscelatore, soffione S06 e doccia
 Shower column with mixer, showerhead S06 and handshower
 Colonne douche avec mitigeur, pomme de douche S06 et douchette
 Columna de ducha con monomando, rociador S06 y teleducha
 Duschsäule mit Einhebelmischer, Kopfbrause S06 und Handbrause

✓	C50AS.ME/MX
	C50AS.ME/BX
	C50AS.ME/MB
	C50AS.ME/RL
CW	Corpo incasso_Concealed body_Corps encastré_Cuerpo empotrado_UP-Teil (pag. 209)
	CW.1
	Parti esterne_External parts_Parties externes_Parties externas_AP-Teile
	C50AS.XCW.ME/MX
	C50AS.XCW.ME/BX
	C50AS.XCW.ME/MB
	C50AS.XCW.ME/RL
EW	C50AS.EW.ME/MX
	C50AS.EW.ME/BX
	C50AS.EW.ME/MB
	C50AS.EW.ME/RL



CLUB



Shower

pag. 116

CLUB

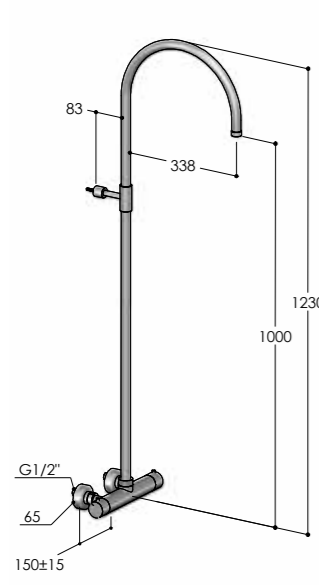

W154

Gruppo esterno con colonna doccia e soffione incassato
 Wall-mounted shower mixer, with column and concealed showerhead
 Mélangeur douche avec colonne et pomme de douche intégrée
 Batería para ducha con columna y rociador integrado
 AP-Brausebatterie mit Stange und integrierter Kopfbrause

- W154/MX**
 W154/BX
 W154/MB
 W154/RL
 W154/BB
 W154/BC
 W154/AB
 W154/DB

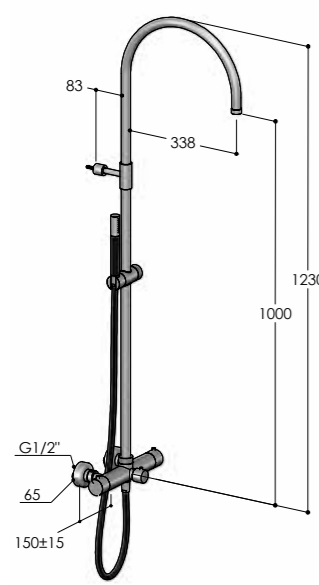

W154.E

Gruppo esterno con colonna doccia, soffione incassato e doccetta
 Wall-mounted shower mixer, with column, concealed showerhead and handshower
 Mélangeur douche avec colonne, pomme de douche intégrée et douchette
 Batería para ducha con columna, rociador integrado y teleducha
 AP-Brausebatterie mit Stange, integrierter Kopfbrause und Handbrause

- W154.E/MX**
 W154.E/BX
 W154.E/MB
 W154.E/RL
 W154.E/BB
 W154.E/BC
 W154.E/AB
 W154.E/DB

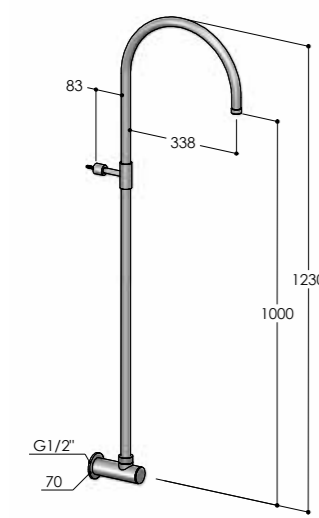

W1X7

Preso d'acqua con colonna doccia e soffione incassato
 Wall coupling, with column and concealed showerhead
 Coude de sortie, avec colonne et pomme de douche intégrée
 Codo mural, con columna y rociador integrado
 Wandanschlußbogen mit Stange und integrierter Kopfbrause

- W1X7/MX**
 W1X7/BX
 W1X7/MB
 W1X7/RL
 W1X7/BB
 W1X7/BC
 W1X7/AB
 W1X7/DB

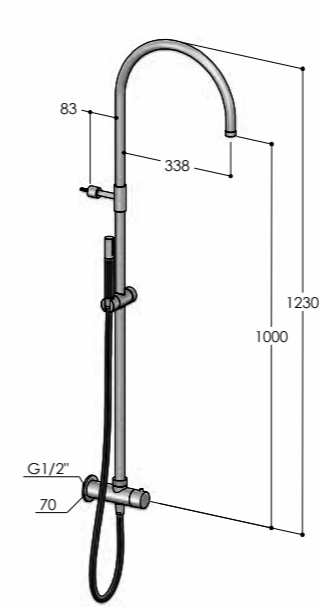

W159.E

Preso d'acqua con colonna doccia, soffione incassato e doccetta
 Wall coupling, with column, concealed showerhead and handshower
 Coude de sortie, avec colonne, pomme de douche intégrée et douchette
 Codo mural, con columna, rociador integrado y teleducha
 Wandanschlußbogen mit Stange, integrierter Kopfbrause und Handbrause

- W159.E/MX**
 W159.E/BX
 W159.E/MB
 W159.E/RL
 W159.E/BB
 W159.E/BC
 W159.E/AB
 W159.E/DB

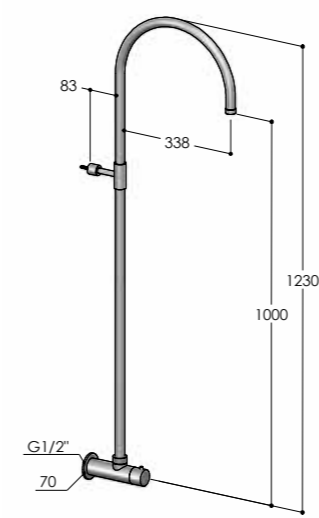

W157C

Rubinetto esterno con colonna doccia e soffione incassato
 Wall-mounted tap with column and concealed showerhead
 Robinet mural avec colonne et pomme de douche intégrée
 Grifo mural con columna y rociador integrado
 AP-Ventil mit Stange und integrierter Kopfbrause

- W157C/MX**
 W157C/BX
 W157C/MB
 W157C/RL
 W157C/BB
 W157C/BC
 W157C/AB
 W157C/DB

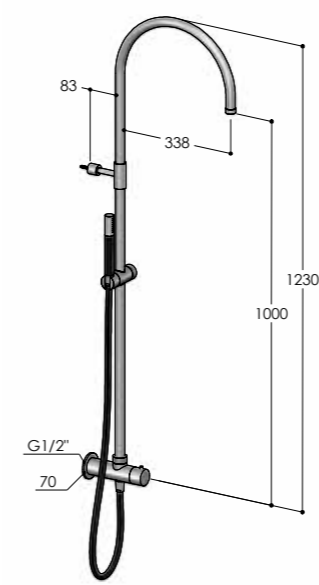

W159C.E

Rubinetto esterno con colonna doccia, soffione incassato e doccetta
 Wall-mounted tap with column, concealed showerhead and handshower
 Robinet mural avec colonne, pomme de douche intégrée et douchette
 Grifo mural con columna, rociador integrado y teleducha
 AP-Ventil mit Stange, integrierter Kopfbrause und Handbrause

- W159C.E/MX**
 W159C.E/BX
 W159C.E/MB
 W159C.E/RL
 W159C.E/BB
 W159C.E/BC
 W159C.E/AB
 W159C.E/DB

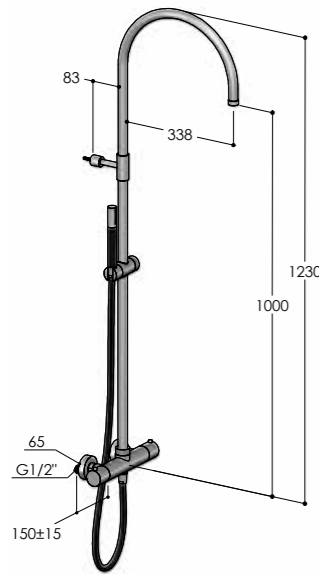

W15A6.E



Miscelatore termostatico esterno con colonna doccia, soffione incassato e doccetta
 Wall-mounted thermostatic mixer, with column, concealed showerhead and handshower
 Mitigeur thermostatique mural avec colonne, pomme de douche intégrée et douchette
 Mezclador termostatico mural con columna, rociador integrado y teleducha
 AP-Thermostat-Brausemischer mit Stange, integrierter Kopfbrause und Handbrause

W15A6.E/MX

- W15A6.E/BX
- W15A6.E/MB
- W15A6.E/RL
- W15A6.E/BB
- W15A6.E/BC
- W15A6.E/AB
- W15A6.E/DB

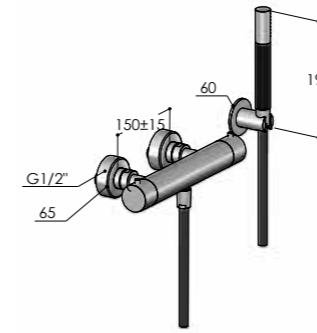

WX54.SK



Gruppo esterno con kit doccia
 Wall-mounted mixer with shower kit
 Mélangeur mural avec kit de douche
 Batería con kit de ducha mural
 AP-Batterie mit Brausekit

WX54.SK/MX

- WX54.SK/BX
- WX54.SK/MB
- WX54.SK/RL
- WX54.SK/BB
- WX54.SK/BC
- WX54.SK/AB
- WX54.SK/DB

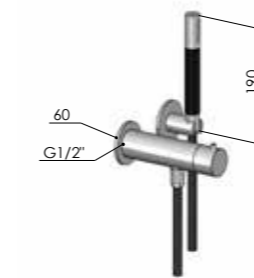

WX57C.SK



Rubinetto esterno con kit doccia
 Wall-mounted tap with shower kit
 Robinet mural avec kit de douche
 Grifo mural con kit de ducha
 AP-Ventil, mit Brausekit

WX57C.SK/MX

- WX57C.SK/BX
- WX57C.SK/MB
- WX57C.SK/RL
- WX57C.SK/BB
- WX57C.SK/BC
- WX57C.SK/AB
- WX57C.SK/DB

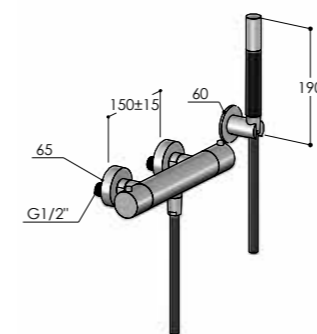

WX5A6.SK



Miscelatore termostatico esterno con kit doccia
 Wall-mounted thermostatic mixer with shower kit
 Mitigeur thermostatique mural avec kit de douche
 Mezclador termostatico mural con kit de ducha
 AP-Thermostat-Brausemischer mit Brausekit

WX5A6.SK/MX

- WX5A6.SK/BX
- WX5A6.SK/MB
- WX5A6.SK/RL
- WX5A6.SK/BB
- WX5A6.SK/BC
- WX5A6.SK/AB
- WX5A6.SK/DB

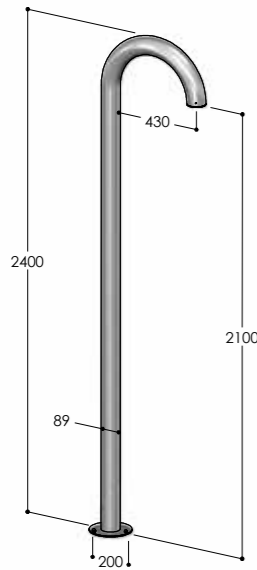

C90.RC

Colonna doccia con soffione incassato per comando remoto
 Shower column with concealed showerhead for remote control
 Colonne douche avec pomme de douche intégrée pour commande à distance
 Columna de ducha con rociador integrado para control remoto
 Duschsäule mit integrierter Kopfbrause für Fernsteuerung

C90.RC/MX
C90.RC/BX
C90.RC/MB
C90.RC/RL
Corpo incasso_Concealed body_Corps encastré_Cuerpo empotrado_UP-Teil (pag. 209)
CW.1
Parti esterne_External parts_Parties externes_Parties externas_AP-Teile
C90.XCW.RC/MX
C90.XCW.RC/BX
C90.XCW.RC/MB
C90.XCW.RC/RL
C90.EW.RC/MX
C90.EW.RC/BX
C90.EW.RC/MB
C90.EW.RC/RL
C90.4S.RC/MX
C90.4S.RC/BX
C90.4S.RC/MB
C90.4S.RC/RL

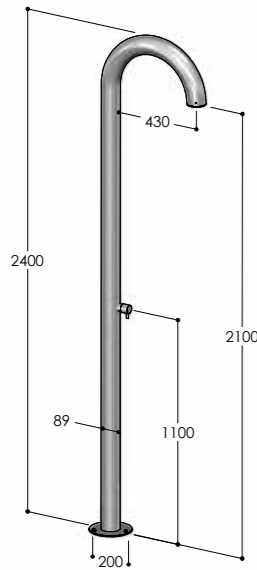

C90

Colonna doccia con rubinetto d'arresto e soffione incassato
 Shower column with stop tap and concealed showerhead
 Colonne douche avec robinet d'arrêt et pomme de douche intégrée
 Columna de ducha con grifo y rociador integrado
 Duschsäule mit Wasserhahn und integrierter Kopfbrause

C90/MX
C90/BX
C90/MB
C90/RL
Corpo incasso_Concealed body_Corps encastré_Cuerpo empotrado_UP-Teil (pag. 209)
CW.1
Parti esterne_External parts_Parties externes_Parties externas_AP-Teile
C90.XCW/MX
C90.XCW/BX
C90.XCW/MB
C90.XCW/RL
C90.EW/MX
C90.EW/BX
C90.EW/MB
C90.EW/RL
C90.4S/MX
C90.4S/BX
C90.4S/MB
C90.4S/RL

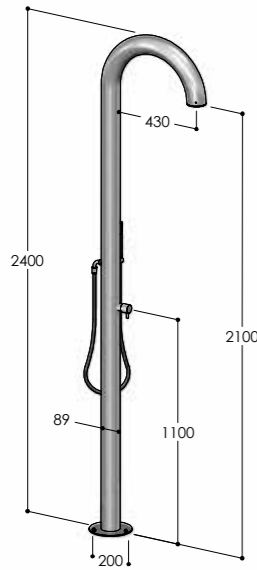

C90.E

Colonna doccia con rubinetto d'arresto, soffione incassato e doccia
 Shower column with stop tap, concealed showerhead and handshower
 Colonne douche avec robinet d'arrêt, pomme de douche intégrée et douchette
 Columna de ducha con grifo, rociador integrado y teleducha
 Duschsäule mit Wasserhahn, integrierter Kopfbrause und Handbrause

C90.E/MX
C90.E/BX
C90.E/MB
C90.E/RL
Corpo incasso_Concealed body_Corps encastré_Cuerpo empotrado_UP-Teil (pag. 209)
CW.1
Parti esterne_External parts_Parties externes_Parties externas_AP-Teile
C90.XCW.E/MX
C90.XCW.E/BX
C90.XCW.E/MB
C90.XCW.E/RL
C90.EW.E/MX
C90.EW.E/BX
C90.EW.E/MB
C90.EW.E/RL
C90.4S.E/MX
C90.4S.E/BX
C90.4S.E/MB
C90.4S.E/RL

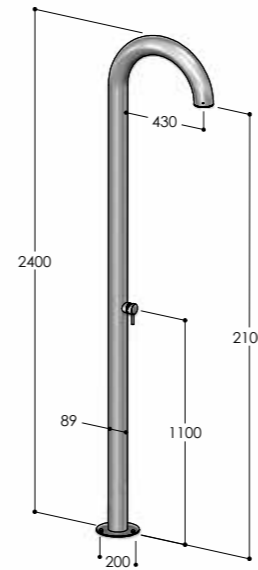

C90.M

Colonna doccia con miscelatore e soffione incassato
 Shower column with mixer and concealed showerhead
 Colonne douche avec mitigeur et pomme de douche intégrée
 Columna de ducha con monomando y rociador integrado
 Duschsäule mit Einhebelmischer und integrierter Kopfbrause

C90.M/MX
C90.M/BX
C90.M/MB
C90.M/RL
Corpo incasso_Concealed body_Corps encastré_Cuerpo empotrado_UP-Teil (pag. 209)
CW.2
Parti esterne_External parts_Parties externes_Parties externas_AP-Teile
C90.XCW.M/MX
C90.XCW.M/BX
C90.XCW.M/MB
C90.XCW.M/RL
C90.EW.M/MX
C90.EW.M/BX
C90.EW.M/MB
C90.EW.M/RL
C90.4S.M/MX
C90.4S.M/BX
C90.4S.M/MB
C90.4S.M/RL

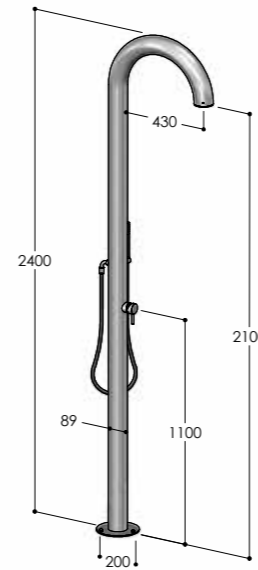

C90.ME

Colonna doccia con miscelatore, soffione incassato e doccia
 Shower column with mixer, concealed showerhead and handshower
 Colonne douche avec mitigeur, pomme de douche intégrée et douchette
 Columna de ducha con monomando, rociador integrado y teleducha
 Duschsäule mit Einhebelmischer, integrierter Kopfbrause und Handbrause

C90.ME/MX
C90.ME/BX
C90.ME/MB
C90.ME/RL
Corpo incasso_Concealed body_Corps encastré_Cuerpo empotrado_UP-Teil (pag. 209)
CW.2
Parti esterne_External parts_Parties externes_Parties externas_AP-Teile
C90.XCW.ME/MX
C90.XCW.ME/BX
C90.XCW.ME/MB
C90.XCW.ME/RL
C90.EW.ME/MX
C90.EW.ME/BX
C90.EW.ME/MB
C90.EW.ME/RL
C90.4S.ME/MX
C90.4S.ME/BX
C90.4S.ME/MB
C90.4S.ME/RL



CLUB LARGE



CLUB LARGE

Shower

pag. 124

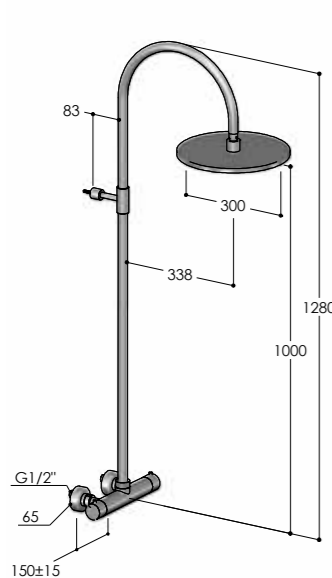

W254



Gruppo esterno con colonna doccia e soffione S10
 Wall-mounted shower mixer, with column and showerhead S10
 Mélangeur douche avec colonne et pomme de douche S10
 Batería para ducha con columna y rociador S10
 AP-Brausebatterie mit Stange und Kopfbrause S10

W254/MX

- W254/BX
- W254/MB
- W254/RL
- W254/BB
- W254/BC
- W254/AB
- W254/DB

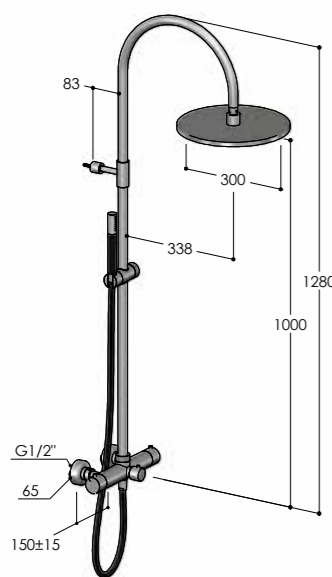

W254.E



Gruppo esterno con colonna doccia, soffione S10 e doccetta
 Wall-mounted shower mixer, with column, showerhead S10 and handshower
 Mélangeur douche avec colonne, pomme de douche S10 et douchette
 Batería para ducha con columna, rociador S10 y teleducha
 AP-Brausebatterie mit Stange, Kopfbrause S10 und Handbrause

W254.E/MX

- W254.E/BX
- W254.E/MB
- W254.E/RL
- W254.E/BB
- W254.E/BC
- W254.E/AB
- W254.E/DB

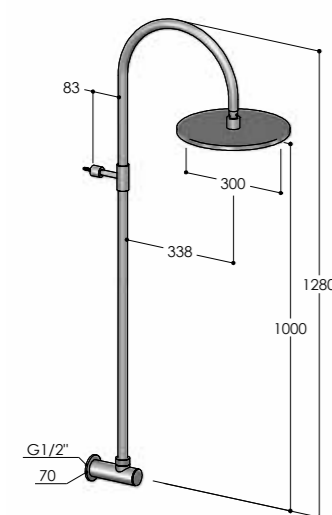

W2X7

Preso d'acqua con colonna doccia e soffione S10
 Wall coupling, with column and showerhead S10
 Coude de sortie, avec colonne et pomme de douche S10
 Codo mural, con columna y rociador S10
 Wandanschlußbogen mit Stange und Kopfbrause S10

W2X7/MX

- W2X7/BX
- W2X7/MB
- W2X7/RL
- W2X7/BB
- W2X7/BC
- W2X7/AB
- W2X7/DB

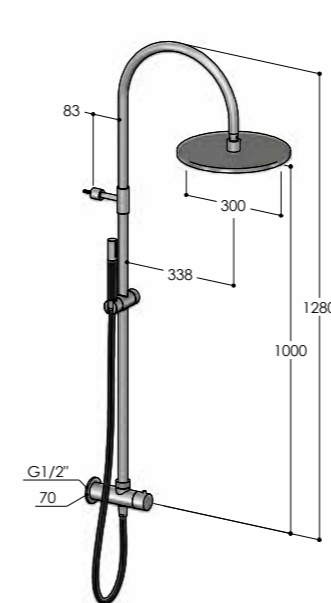

W259.E



Preso d'acqua con colonna doccia, soffione S10 e doccetta
 Wall coupling, with column, showerhead S10 and handshower
 Coude de sortie, avec colonne, pomme de douche S10 et douchette
 Codo mural, con columna, rociador S10 y teleducha
 Wandanschlußbogen mit Stange, Kopfbrause S10 und Handbrause

W259.E/MX

- W259.E/BX
- W259.E/MB
- W259.E/RL
- W259.E/BB
- W259.E/BC
- W259.E/AB
- W259.E/DB

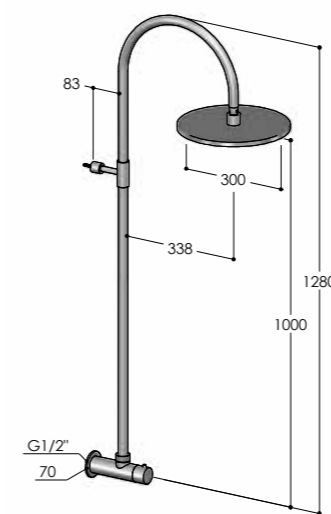

W257C



Rubinetto esterno con colonna doccia e soffione S10
 Wall-mounted tap with column and showerhead S10
 Robinet mural avec colonne et pomme de douche S10
 Grifo mural con columna y rociador S10
 AP-Ventil mit Stange und Kopfbrause S10

W257C/MX

- W257C/BX
- W257C/MB
- W257C/RL
- W257C/BB
- W257C/BC
- W257C/AB
- W257C/DB

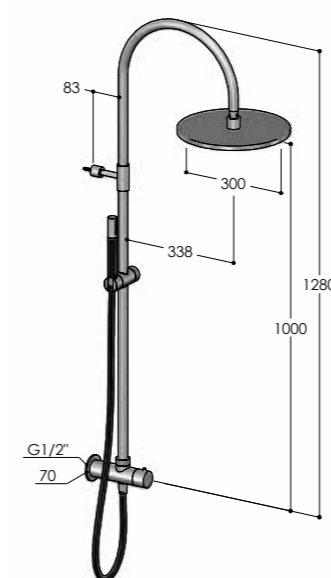

W259C.E



Rubinetto esterno con colonna doccia, soffione S10 e doccetta
 Wall-mounted tap with column, showerhead S10 and handshower
 Robinet mural avec colonne, pomme de douche S10 et douchette
 Grifo mural con columna, rociador S10 y teleducha
 AP-Ventil mit Stange, Kopfbrause S10 und Handbrause

W259C.E/MX

- W259C.E/BX
- W259C.E/MB
- W259C.E/RL
- W259C.E/BB
- W259C.E/BC
- W259C.E/AB
- W259C.E/DB

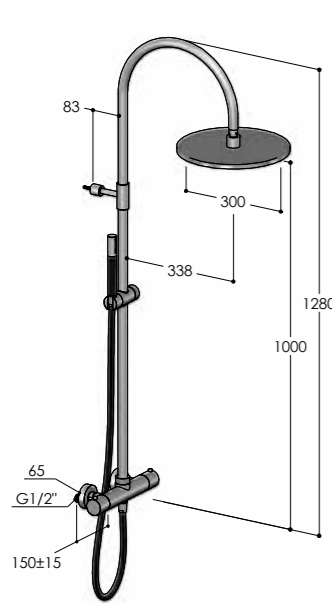

W25A6.E



Miscelatore termostatico esterno con colonna doccia, soffione S10 e doccetta
 Wall-mounted thermostatic mixer, with column, showerhead S10 and handshower
 Mitigeur thermostatique mural avec colonne, pomme de douche S10 et douchette
 Mezclador termostatico mural con columna, rociador S10 y teleducha
 AP-Thermostat-Brausemischer mit Stange, Kopfbrause S10 und Handbrause

W25A6.E/MX

- W25A6.E/BX
- W25A6.E/MB
- W25A6.E/RL
- W25A6.E/BB
- W25A6.E/BC
- W25A6.E/AB
- W25A6.E/DB

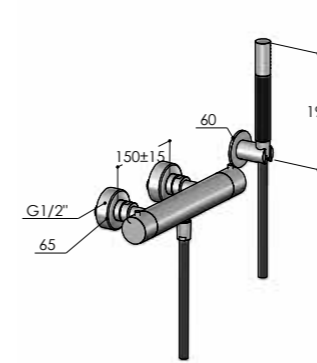

WX54.SK



Gruppo esterno con kit doccia
 Wall-mounted mixer with shower kit
 Mélangeur mural avec kit de douche
 Batería con kit de ducha mural
 AP-Batterie mit Brausekit

WX54.SK/MX

- WX54.SK/BX
- WX54.SK/MB
- WX54.SK/RL
- WX54.SK/BB
- WX54.SK/BC
- WX54.SK/AB
- WX54.SK/DB

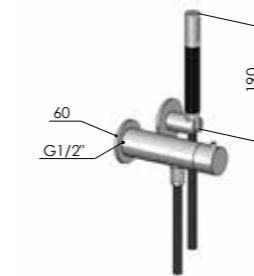

WX57C.SK



Rubinetto esterno con kit doccia
 Wall-mounted tap with shower kit
 Robinet mural avec kit de douche
 Grifo mural con kit de ducha
 AP-Ventil, mit Brausekit

WX57C.SK/MX

- WX57C.SK/BX
- WX57C.SK/MB
- WX57C.SK/RL
- WX57C.SK/BB
- WX57C.SK/BC
- WX57C.SK/AB
- WX57C.SK/DB

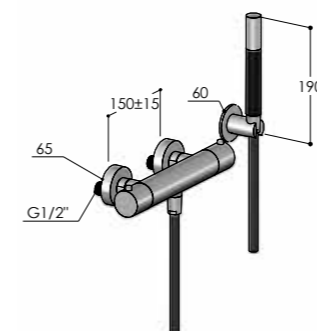

WX5A6.SK



Miscelatore termostatico esterno con kit doccia
 Wall-mounted thermostatic mixer with shower kit
 Mitigeur thermostatique mural avec kit de douche
 Mezclador termostatico mural con kit de ducha
 AP-Thermostat-Brausemischer mit Brausekit

WX5A6.SK/MX

- WX5A6.SK/BX
- WX5A6.SK/MB
- WX5A6.SK/RL
- WX5A6.SK/BB
- WX5A6.SK/BC
- WX5A6.SK/AB
- WX5A6.SK/DB

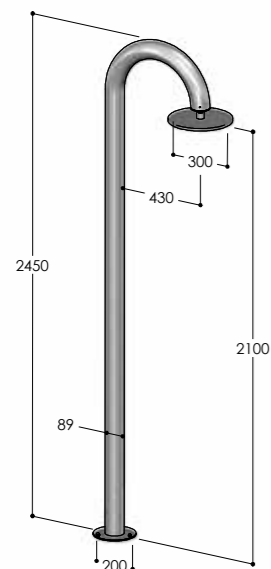

CL90.RC

Colonna doccia con soffione S10 per comando remoto
 Shower column with showerhead S10 for remote control
 Colonne douche avec pomme de douche S10 pour commande à distance
 Columna de ducha con rociador S10 para control remoto
 Duschsäule mit Kopfbrause S10 für Fernsteuerung

✓	CL90.RC/MX CL90.RC/BX CL90.RC/MB CL90.RC/RL
	Corpo incasso_Concealed body_Corps encastré_Cuerpo empotrado_UP-Teil (pag. 209)
	CW.1 Parti esterne_External parts_Parties externes_Parties externas_AP-Teile
CW	CL90.XCW.RC/MX CL90.XCW.RC/BX CL90.XCW.RC/MB CL90.XCW.RC/RL
EW	CL90.EW.RC/MX CL90.EW.RC/BX CL90.EW.RC/MB CL90.EW.RC/RL
4S	CL90.4S.RC/MX CL90.4S.RC/BX CL90.4S.RC/MB CL90.4S.RC/RL

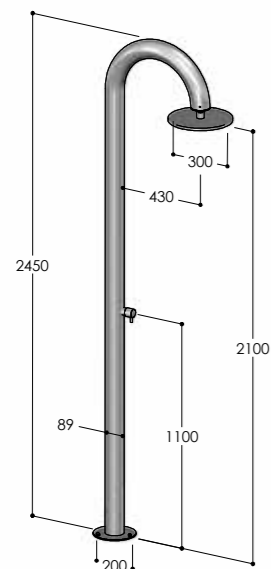

CL90

Colonna doccia con rubinetto d'arresto e soffione S10
 Shower column with stop tap and showerhead S10
 Colonne douche avec robinet d'arrêt et pomme de douche S10
 Columna de ducha con grifo y rociador S10
 Duschsäule mit Wasserhahn und Kopfbrause S10

✓	CL90/MX CL90/BX CL90/MB CL90/RL
	Corpo incasso_Concealed body_Corps encastré_Cuerpo empotrado_UP-Teil (pag. 209)
	CW.1 Parti esterne_External parts_Parties externes_Parties externas_AP-Teile
CW	CL90.XCW/MX CL90.XCW/BX CL90.XCW/MB CL90.XCW/RL
EW	CL90.EW/MX CL90.EW/BX CL90.EW/MB CL90.EW/RL
4S	CL90.4S/MX CL90.4S/BX CL90.4S/MB CL90.4S/RL

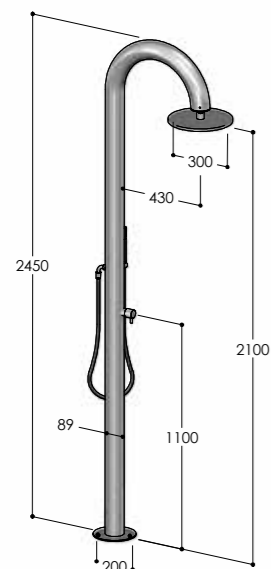

CL90.E

Colonna doccia con rubinetto d'arresto, soffione S10 e doccia
 Shower column with stop tap, showerhead S10 and handshower
 Colonne douche avec robinet d'arrêt, pomme de douche S10 et douchette
 Columna de ducha con grifo, rociador S10 y teleducha
 Duschsäule mit Wasserhahn, Kopfbrause S10 und Handbrause

✓	CL90.E/MX CL90.E/BX CL90.E/MB CL90.E/RL
	Corpo incasso_Concealed body_Corps encastré_Cuerpo empotrado_UP-Teil (pag. 209)
	CW.1 Parti esterne_External parts_Parties externes_Parties externas_AP-Teile
CW	CL90.XCW.E/MX CL90.XCW.E/BX CL90.XCW.E/MB CL90.XCW.E/RL
EW	CL90.EW.E/MX CL90.EW.E/BX CL90.EW.E/MB CL90.EW.E/RL
4S	CL90.4S.E/MX CL90.4S.E/BX CL90.4S.E/MB CL90.4S.E/RL

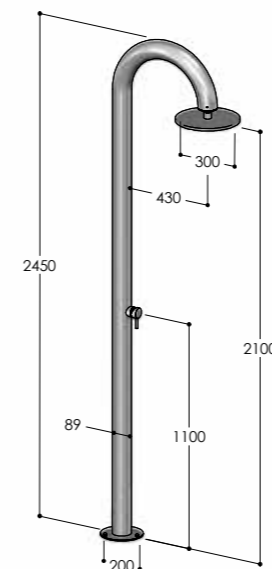

CL90.M

Colonna doccia con miscelatore e soffione S10
 Shower column with mixer and showerhead S10
 Colonne douche avec mitigeur et pomme de douche S10
 Columna de ducha con monomando y rociador S10
 Duschsäule mit Einhebelmischer und Kopfbrause S10

✓	CL90.M/MX CL90.M/BX CL90.M/MB CL90.M/RL
	Corpo incasso_Concealed body_Corps encastré_Cuerpo empotrado_UP-Teil (pag. 209)
	CW.2 Parti esterne_External parts_Parties externes_Parties externas_AP-Teile
CW	CL90.XCW.M/MX CL90.XCW.M/BX CL90.XCW.M/MB CL90.XCW.M/RL
EW	CL90.EW.M/MX CL90.EW.M/BX CL90.EW.M/MB CL90.EW.M/RL
4S	CL90.4S.M/MX CL90.4S.M/BX CL90.4S.M/MB CL90.4S.M/RL

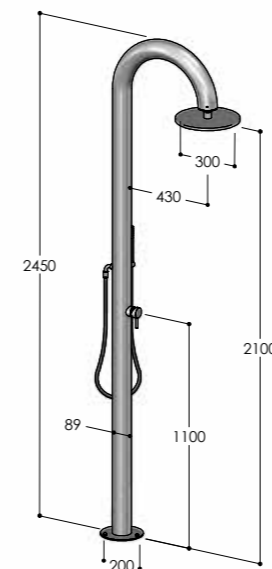

CL90.ME

Colonna doccia con miscelatore, soffione S10 e doccia
 Shower column with mixer, showerhead S10 and handshower
 Colonne douche avec mitigeur, pomme de douche S10 et douchette
 Columna de ducha con monomando, rociador S10 y teleducha
 Duschsäule mit Einhebelmischer, Kopfbrause S10 und Handbrause

✓	CL90.ME/MX CL90.ME/BX CL90.ME/MB CL90.ME/RL
	Corpo incasso_Concealed body_Corps encastré_Cuerpo empotrado_UP-Teil (pag. 209)
	CW.2 Parti esterne_External parts_Parties externes_Parties externas_AP-Teile
CW	CL90.XCW.ME/MX CL90.XCW.ME/BX CL90.XCW.ME/MB CL90.XCW.ME/RL
EW	CL90.EW.ME/MX CL90.EW.ME/BX CL90.EW.ME/MB CL90.EW.ME/RL
4S	CL90.4S.ME/MX CL90.4S.ME/BX CL90.4S.ME/MB CL90.4S.ME/RL



ORIGO RAME

Shower

pag. 132



ORIGO RAME

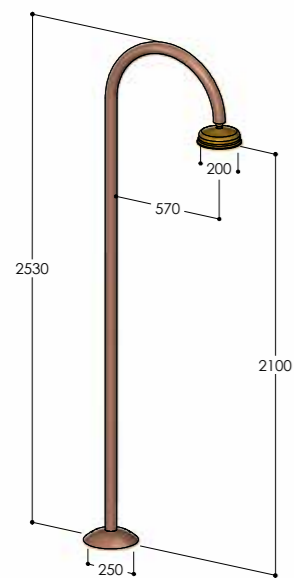

C50R.RC

Colonna doccia in rame con soffione S08 per comando remoto
 Shower column in copper with showerhead S08 for remote control
 Colonne douche en cuivre avec pomme de douche S08 pour commande à distance
 Columna de ducha en cobre con rociador S08 para control remoto
 Duschsäule aus Kupfer mit Kopfbrause S08 für Fernsteuerung

✓ **C50R.RC**
 EW **C50R.EW.RC**

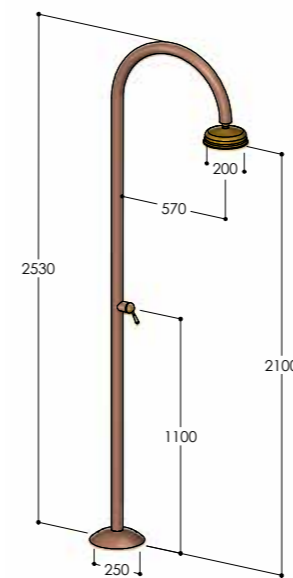

C50R.M

Colonna doccia in rame con miscelatore e soffione S08
 Shower column in copper with mixer and showerhead S08
 Colonne douche en cuivre avec mitigeur et pomme de douche S08
 Columna de ducha en cobre con monomando y rociador S08
 Duschsäule aus Kupfer mit Einhebelmischer und Kopfbrause S08

✓ **C50R.M**
 EW **C50R.EW.M**

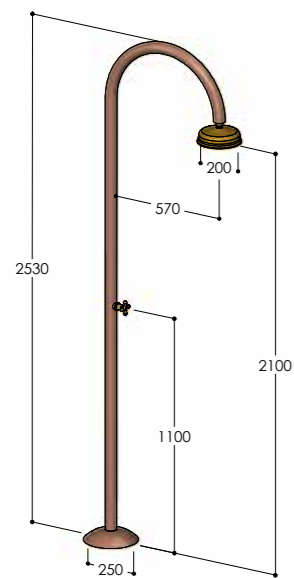

C50R

Colonna doccia in rame con rubinetto d'arresto e soffione S08
 Shower column in copper with stop tap and showerhead S08
 Colonne douche en cuivre avec robinet d'arrêt et pomme de douche S08
 Columna de ducha en cobre con grifo y rociador S08
 Duschsäule aus Kupfer mit Wasserhahn und Kopfbrause S08

✓ **C50R**
 EW **C50R.EW**

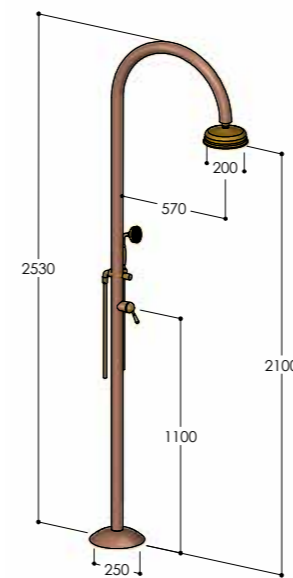

C50R.ME

Colonna doccia in rame con miscelatore, soffione S08 e doccia
 Shower column in copper with mixer, showerhead S08 and handshower
 Colonne douche en cuivre avec mitigeur, pomme de douche S08 et douchette
 Columna de ducha en cobre con monomando, rociador S08 y teleducha
 Duschsäule aus Kupfer mit Einhebelmischer, Kopfbrause S08 und Handbrause

✓ **C50R.ME**
 EW **C50R.EW.ME**

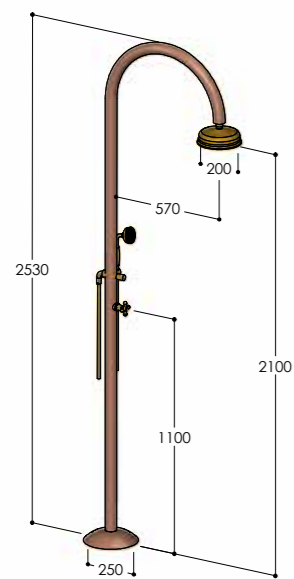

C50R.E

Colonna doccia in rame con rubinetto d'arresto, soffione S08 e doccia
 Shower column in copper with stop tap, showerhead S08 and handshower
 Colonne douche en cuivre avec robinet d'arrêt, pomme de douche S08 et douchette
 Columna de ducha en cobre con grifo, rociador S08 y teleducha
 Duschsäule aus Kupfer mit Wasserhahn, Kopfbrause S08 und Handbrause

✓ **C50R.E**
 EW **C50R.EW.E**



ONDA



Shower

pag. 136

ONDA

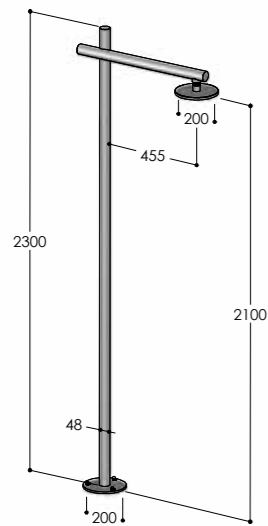

D50.RC

Colonna doccia con soffione S06 per comando remoto
 Shower column with S06 showerhead for remote control
 Colonne douche avec pomme de douche S06 pour commande à distance
 Columna de ducha con rociador S06 para control remoto
 Duschsäule mit Kopfbrause S06 für Fernsteuerung

✓	D50.RC/MX D50.RC/BX
	Corpo incasso_Concealed body_Corps encastré_Cuerpo empotrado_UP-Teil (pag. 209)
	CW.1
CW	Parti esterne_External parts_Parties externes_Parties externas_AP-Teile
	D50.XCW.RC/MX D50.XCW.RC/BX
EW	D50.EW.RC/MX D50.EW.RC/BX

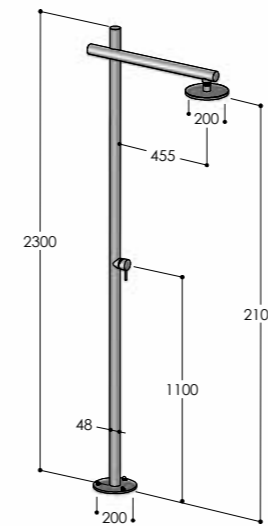

D50.M

Colonna doccia con miscelatore e soffione S06
 Shower column with mixer and showerhead S06
 Colonne douche avec mitigeur et pomme de douche S06
 Columna de ducha con monomando y rociador S06
 Duschsäule mit Einhebelmischer und Kopfbrause S06

✓	D50.M/MX D50.M/BX
	Corpo incasso_Concealed body_Corps encastré_Cuerpo empotrado_UP-Teil (pag. 209)
	CW.2
CW	Parti esterne_External parts_Parties externes_Parties externas_AP-Teile
	D50.XCW.M/MX D50.XCW.M/BX
EW	D50.EW.M/MX D50.EW.M/BX

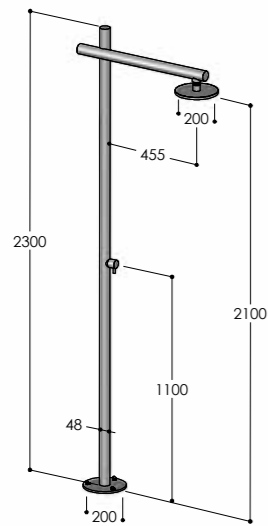

D50

Colonna doccia con rubinetto d'arresto e soffione S06
 Shower column with stop tap and S06 showerhead
 Colonne douche avec robinet d'arrêt et pomme de douche S06
 Columna de ducha con grifo y rociador S06
 Duschsäule mit Wasserhahn und Kopfbrause S06

✓	D50/MX D50/BX
	Corpo incasso_Concealed body_Corps encastré_Cuerpo empotrado_UP-Teil (pag. 209)
	CW.1
CW	Parti esterne_External parts_Parties externes_Parties externas_AP-Teile
	D50.XCW/MX D50.XCW/BX
EW	D50.EW/MX D50.EW/BX

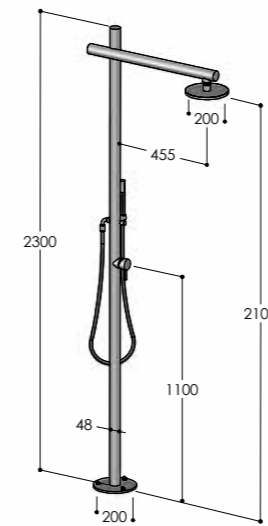

D50.ME

Colonna doccia con miscelatore, soffione S06 e doccia
 Shower column with mixer, showerhead S06 and handshower
 Colonne douche avec mitigeur, pomme de douche S06 et douchette
 Columna de ducha con monomando, rociador S06 y teleducha
 Duschsäule mit Einhebelmischer, Kopfbrause S06 und Handbrause

✓	D50.ME/MX D50.ME/BX
	Corpo incasso_Concealed body_Corps encastré_Cuerpo empotrado_UP-Teil (pag. 209)
	CW.2
CW	Parti esterne_External parts_Parties externes_Parties externas_AP-Teile
	D50.XCW.ME/MX D50.XCW.ME/BX
EW	D50.EW.ME/MX D50.EW.ME/BX

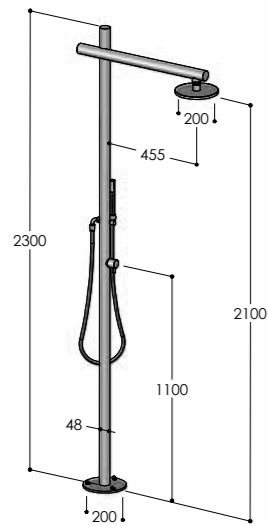

D50.E

Colonna doccia con rubinetto d'arresto, soffione S06 e doccia
 Shower column with stop tap, S06 showerhead and handshower
 Colonne douche avec robinet d'arrêt, pomme de douche S06 et douchette
 Columna de ducha con grifo, rociador S06 y teleducha
 Duschsäule mit Wasserhahn, Kopfbrause S06 und Handbrause

✓	D50.E/MX D50.E/BX
	Corpo incasso_Concealed body_Corps encastré_Cuerpo empotrado_UP-Teil (pag. 209)
	CW.1
CW	Parti esterne_External parts_Parties externes_Parties externas_AP-Teile
	D50.XCW.E/MX D50.XCW.E/BX
EW	D50.EW.E/MX D50.EW.E/BX



ARKO

Shower

pag. 140

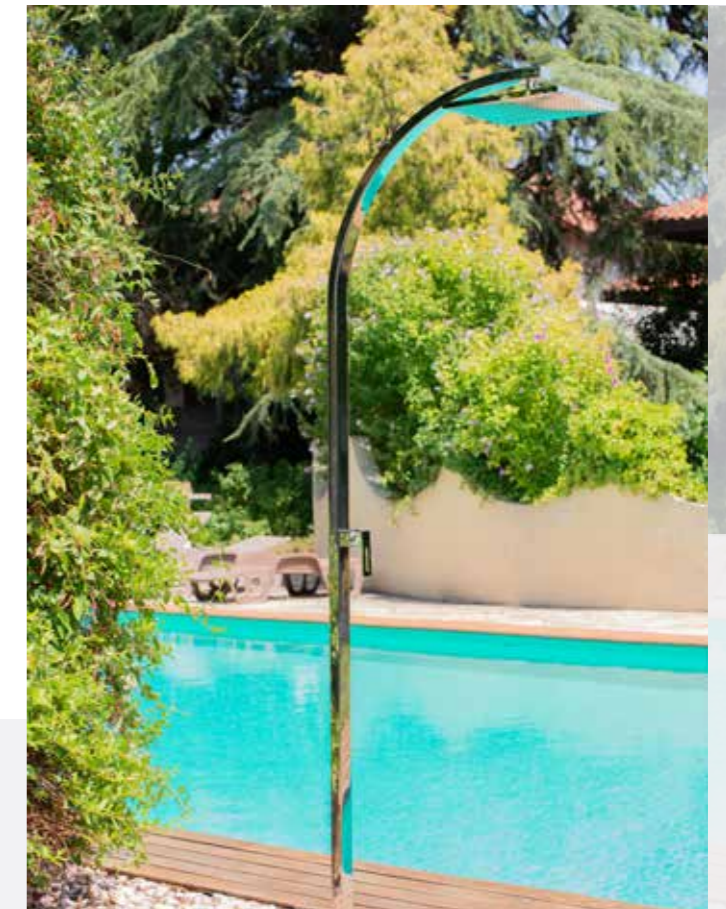

ARKO

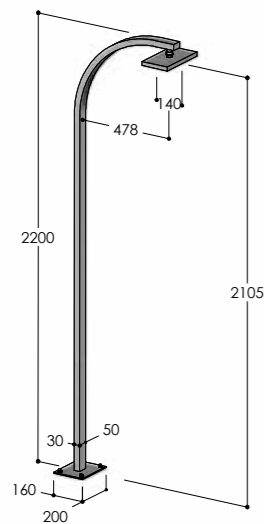

Q53.RC

Colonna doccia con soffione S09 per comando remoto
 Shower column with S09 showerhead for remote control
 Colonne douche avec pomme de douche S09 pour commande à distance
 Columna de ducha con rociador S09 para control remoto
 Duschsäule mit Kopfbrause S09 für Fernsteuerung

✓	Q53.RC/MX Q53.RC/BX Q53.RC/MB Q53.RC/RL
	Corpo incasso_Concealed body_Corps encastré_Cuerpo empotrado_UP-Teil (pag. 209)
	CW.1
CW	Parti esterne_External parts_Parties externes_Parties externas_AP-Teile Q53.XCW.RC/MX Q53.XCW.RC/BX Q53.XCW.RC/MB Q53.XCW.RC/RL

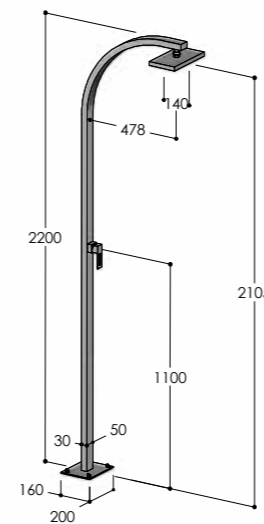

Q53.M

Colonna doccia con miscelatore e soffione S09
 Shower column with mixer and S09 showerhead
 Colonne douche avec mitigeur et pomme de douche S09
 Columna de ducha con monomando y rociador S09
 Duschsäule mit Einhebelmischer und Kopfbrause S09

✓	Q53.M/MX Q53.M/BX Q53.M/MB Q53.M/RL
	Corpo incasso_Concealed body_Corps encastré_Cuerpo empotrado_UP-Teil (pag. 209)
	CW.2
CW	Parti esterne_External parts_Parties externes_Parties externas_AP-Teile Q53.XCW.M/MX Q53.XCW.M/BX Q53.XCW.M/MB Q53.XCW.M/RL

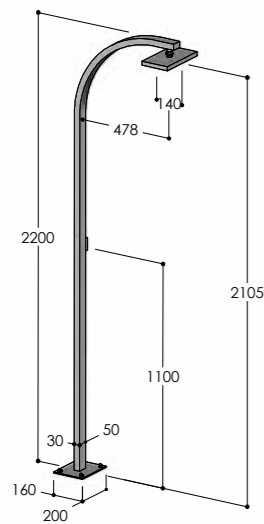

Q53

Colonna doccia con rubinetto d'arresto e soffione S09
 Shower column with stop tap and S09 showerhead
 Colonne douche avec robinet d'arrêt et pomme de douche S09
 Columna de ducha con grifo y rociador S09
 Duschsäule mit Wasserhahn und Kopfbrause S09

✓	Q53/MX Q53/BX Q53/MB Q53/RL
	Corpo incasso_Concealed body_Corps encastré_Cuerpo empotrado_UP-Teil (pag. 209)
	CW.1
CW	Parti esterne_External parts_Parties externes_Parties externas_AP-Teile Q53.XCW/MX Q53.XCW/BX Q53.XCW/MB Q53.XCW/RL

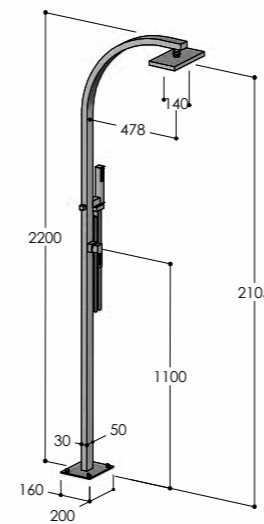

Q53.ME

Colonna doccia con miscelatore, soffione S09 e doccia
 Shower column with mixer, S09 showerhead and handshower
 Colonne douche avec mitigeur, pomme de douche S09 et douchette
 Columna de ducha con monomando, rociador S09 y teleducha
 Duschsäule mit Einhebelmischer, Kopfbrause S09 und Handbrause

✓	Q53.ME/MX Q53.ME/BX Q53.ME/MB Q53.ME/RL
	Corpo incasso_Concealed body_Corps encastré_Cuerpo empotrado_UP-Teil (pag. 209)
	CW.2
CW	Parti esterne_External parts_Parties externes_Parties externas_AP-Teile Q53.XCW.ME/MX Q53.XCW.ME/BX Q53.XCW.ME/MB Q53.XCW.ME/RL

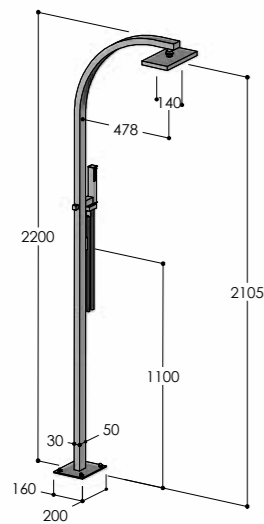

Q53.E

Colonna doccia con rubinetto d'arresto, soffione S09 e doccia
 Shower column with stop tap, S09 showerhead and handshower
 Colonne douche avec robinet d'arrêt, pomme de douche S09 et douchette
 Columna de ducha con grifo, rociador S09 y teleducha
 Duschsäule mit Wasserhahn, Kopfbrause S09 und Handbrause

✓	Q53.E/MX Q53.E/BX Q53.E/MB Q53.E/RL
	Corpo incasso_Concealed body_Corps encastré_Cuerpo empotrado_UP-Teil (pag. 209)
	CW.1
CW	Parti esterne_External parts_Parties externes_Parties externas_AP-Teile Q53.XCW.E/MX Q53.XCW.E/BX Q53.XCW.E/MB Q53.XCW.E/RL



SQUARE

Shower

pag. 144



SQUARE

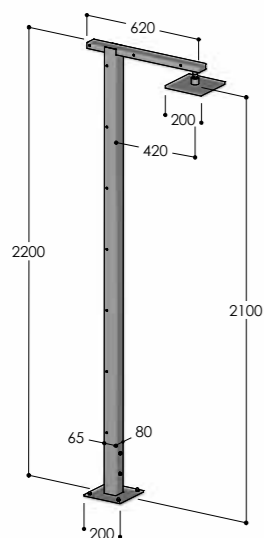

Q86.RC

Colonna doccia con soffione S07 per comando remoto
 Shower column with S07 showerhead for remote control
 Colonne douche avec pomme de douche S07 pour commande à distance
 Columna de ducha con rociador S07 para control remoto
 Duschsäule mit Kopfbrause S07 für Fernsteuerung

- ✓ **Q86.RC/MX**
Q86.RC/BX
- Corpo incasso_Concealed body_Corps encastré_Cuerpo empotrado_UP-Teil (pag. 209)
- CW.1**
- CW** Parti esterne_External parts_Parties externes_Parties externas_AP-Teile
- Q86.XCW.RC/MX**
Q86.XCW.RC/BX

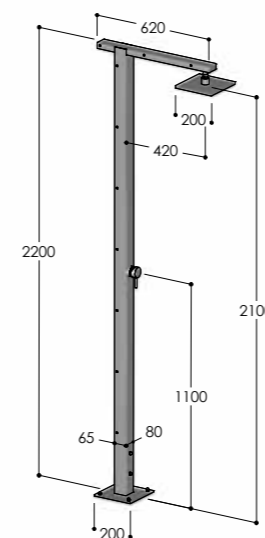

Q86.M

Colonna doccia con miscelatore e soffione S07
 Shower column with mixer and showerhead S07
 Colonne douche avec mitigeur et pomme de douche S07
 Columna de ducha con monomando y rociador S07
 Duschsäule mit Einhebelmischer und Kopfbrause S07

- ✓ **Q86.M/MX**
Q86.M/BX
- Corpo incasso_Concealed body_Corps encastré_Cuerpo empotrado_UP-Teil (pag. 209)
- CW.2**
- CW** Parti esterne_External parts_Parties externes_Parties externas_AP-Teile
- Q86.XCW.M/MX**
Q86.XCW.M/BX

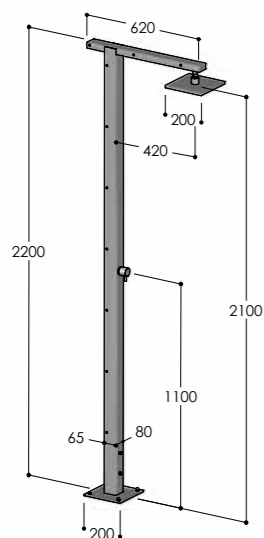

Q86

Colonna doccia con rubinetto d'arresto e soffione S07
 Shower column with stop tap and S07 showerhead
 Colonne douche avec robinet d'arrêt et pomme de douche S07
 Columna de ducha con grifo y rociador S07
 Duschsäule mit Wasserhahn und Kopfbrause S07

- ✓ **Q86/MX**
Q86/BX
- Corpo incasso_Concealed body_Corps encastré_Cuerpo empotrado_UP-Teil (pag. 209)
- CW.1**
- CW** Parti esterne_External parts_Parties externes_Parties externas_AP-Teile
- Q86.XCW/MX**
Q86.XCW/BX

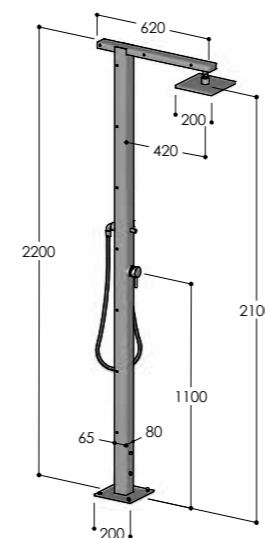

Q86.ME

Colonna doccia con miscelatore, soffione S07 e doccia
 Shower column with mixer, showerhead S07 and handshower
 Colonne douche avec mitigeur, pomme de douche S07 et douchette
 Columna de ducha con monomando, rociador S07 y teleducha
 Duschsäule mit Einhebelmischer, Kopfbrause S07 und Handbrause

- ✓ **Q86.ME/MX**
Q86.ME/BX
- Corpo incasso_Concealed body_Corps encastré_Cuerpo empotrado_UP-Teil (pag. 209)
- CW.2**
- CW** Parti esterne_External parts_Parties externes_Parties externas_AP-Teile
- Q86.XCW.ME/MX**
Q86.XCW.ME/BX

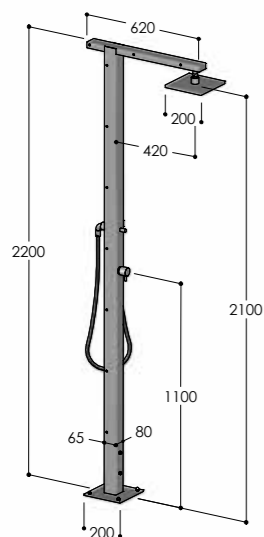

Q86.E

Colonna doccia con rubinetto d'arresto, soffione S07 e doccia
 Shower column with stop tap, S07 showerhead and handshower
 Colonne douche avec robinet d'arrêt, pomme de douche S07 et douchette
 Columna de ducha con grifo, rociador S07 y teleducha
 Duschsäule mit Wasserhahn, Kopfbrause S07 und Handbrause

- ✓ **Q86.E/MX**
Q86.E/BX
- Corpo incasso_Concealed body_Corps encastré_Cuerpo empotrado_UP-Teil (pag. 209)
- CW.1**
- CW** Parti esterne_External parts_Parties externes_Parties externas_AP-Teile
- Q86.XCW.E/MX**
Q86.XCW.E/BX



IN&OUT

Shower

pag. 148



IN&OUT

P9

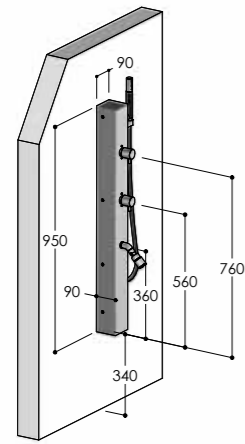

Pannello doccia murale, con 2 rubinetti d'arresto, doccia e lavapiedi
 Wall-mounted shower panel, with 2 stop taps, handshower and footwash
 Colonne douche mural, avec 2 robinets d'arrêt, douche et rince-pieds
 Panel de ducha mural, con 2 grifos, teleducha y lavapies
 Duschpaneel, mit 2 Wasserhähnen, Handbrause und Fußbrause

P9/MX
P9/BX

P22.M

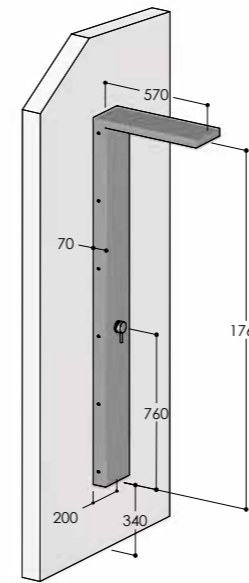

Pannello doccia murale, con miscelatore e soffione incassato 220x110 mm
 Wall-mounted shower panel, with mixer and 220x110 mm concealed showerhead
 Colonne douche mural, avec mitigeur et pomme de douche intégrée 220x110 mm
 Panel de ducha mural, con monomando y rociador integrado 220x110 mm
 Duschpaneel, mit Einhebelmischer und integrierter 220x110 mm Kopfbrause

P22.M/MX
P22.M/BX

P22

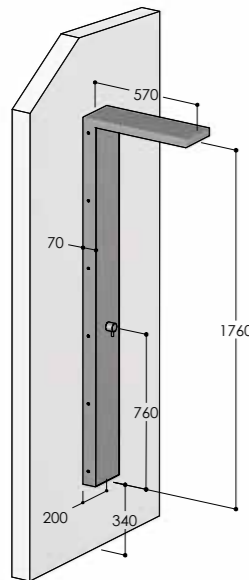

Pannello doccia murale, con rubinetto d'arresto e soffione incassato 220x110 mm
 Wall-mounted shower panel, with stop tap and 220x110 mm concealed showerhead
 Colonne douche mural, avec robinet d'arrêt et pomme de douche intégrée 220x110 mm
 Panel de ducha mural, con grifo y rociador integrado 220x110 mm
 Duschpaneel, mit Wasserhahn und integrierter 220x110 mm Kopfbrause

P22/MX
P22/BX

P22.ME

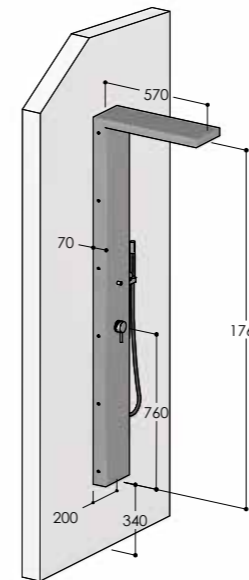

Pannello doccia murale, con miscelatore, soffione 220x110 mm e doccia
 Wall-mounted shower panel, with mixer, 220x110 mm concealed showerhead and handshower
 Colonne douche mural, avec mitigeur, pomme de douche intégrée 220x110 mm et douche
 Panel de ducha mural, con monomando, rociador integrado 220x110 mm y teleducha
 Duschpaneel, mit Einhebelmischer, integrierter 220x110 mm Kopfbrause und Handbrause

P22.ME/MX
P22.ME/BX

P22.E

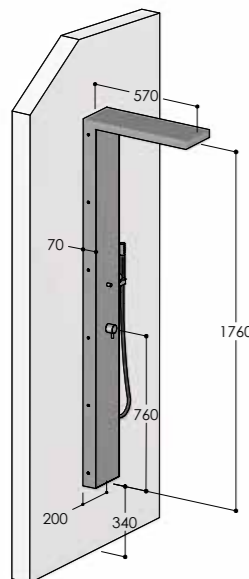

Pannello doccia murale, con rubinetto d'arresto, soffione incassato 220x110 mm e doccia
 Wall-mounted shower panel, with stop tap, 220x110 mm concealed showerhead and handshower
 Colonne douche mural, avec robinet d'arrêt, pomme de douche intégrée 220x110 mm et douche
 Panel de ducha mural, con grifo, rociador integrado 220x110 mm y teleducha
 Duschpaneel, mit Wasserhahn, integrierter 220x110 mm Kopfbrause und Handbrause

P22.E/MX
P22.E/BX

P22.S

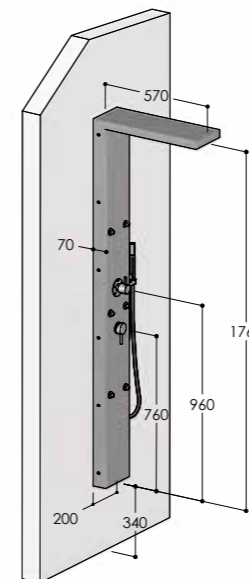

Pannello doccia murale, con miscelatore, deviatore 5 vie, 6 body-jet orientabili, soffione incassato 220x110 mm e doccia
 Wall-mounted shower panel, with mixer, 5-ways diverter, 6 swivel body-jets, 220x110 mm concealed showerhead and handshower
 Colonne douche mural, avec mitigeur, inverseur 5 voies, 6 body-jet orientables, pomme de douche intégrée 220x110 mm et douche
 Panel de ducha mural, con monomando, inversor 5 vías, 6 duchas laterales orientables, rociador integrado 220x110 mm y teleducha
 Duschpaneel, mit Einhebelmischer, 5-Wege Umsteller, 6 schwenkbaren Seitenbrausen, integrierter 220x110 mm Kopfbrause und Handbrause

P22.S/MX
P22.S/BX



SPRING

Garden

pag. 152

Pool

pag. 155



SPRING

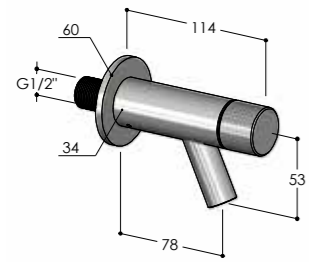

W10

Rubinetto a parete
Wall-mounted tap
Robinet mural
Grifo mural
Wasserhahn für Wandmontage

W10/MX

- W10/BX
- W10/MB
- W10/RL
- W10/BB
- W10/BC
- W10/AB
- W10/DB

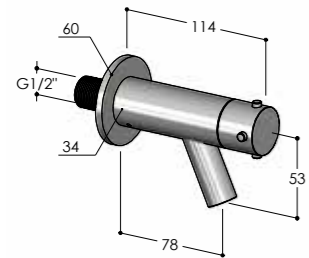

W10.L

Rubinetto a parete
Wall-mounted tap
Robinet mural
Grifo mural
Wasserhahn für Wandmontage

W10.L/MX

- W10.L/BX
- W10.L/MB
- W10.L/RL
- W10.L/BB
- W10.L/BC
- W10.L/AB
- W10.L/DB

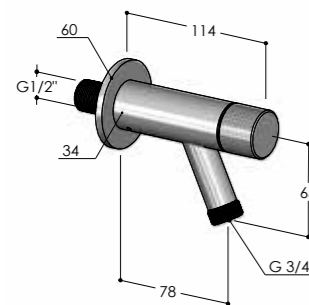

W10.HB

Rubinetto da giardino con raccordo portagomma
Garden tap with hose connection
Robinet de jardin avec raccord cannelé
Grifo de jardin con racor manguera
Garten-Wasserhahn mit Anschluß für Gartenschlauch

W10.HB/MX

- W10.HB/BX
- W10.HB/MB
- W10.HB/RL
- W10.HB/BB
- W10.HB/BC
- W10.HB/AB
- W10.HB/DB

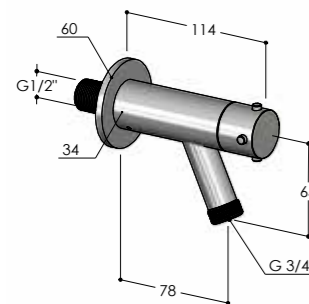

W10.HB.L

Rubinetto da giardino con raccordo portagomma
Garden tap with hose connection
Robinet de jardin avec raccord cannelé
Grifo de jardin con racor manguera
Garten-Wasserhahn mit Anschluß für Gartenschlauch

W10.HB.L/MX

- W10.HB.L/BX
- W10.HB.L/MB
- W10.HB.L/RL
- W10.HB.L/BB
- W10.HB.L/BC
- W10.HB.L/AB
- W10.HB.L/DB

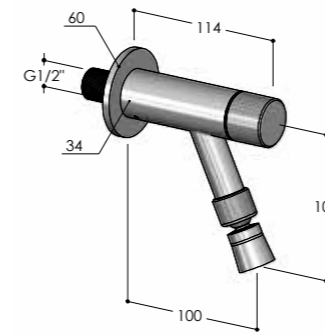

W10.FS

Rubinetto a parete con soffione lavapiedi S03
Wall-mounted tap with foot shower S03
Robinet mural avec douche rince-pieds S03
Grifo mural con ducha lava pies S03
Wasserhahn für Wandmontage, mit Fußbrause S03

W10.FS/MX

- W10.FS/BX
- W10.FS/MB
- W10.FS/RL
- W10.FS/BB
- W10.FS/BC
- W10.FS/AB
- W10.FS/DB

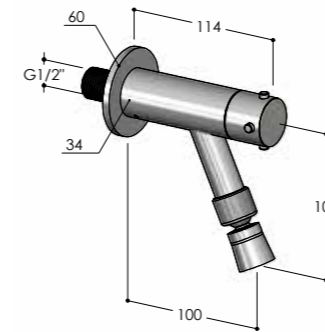

W10.FS.L

Rubinetto a parete con soffione lavapiedi S03
Wall-mounted tap with foot shower S03
Robinet mural avec douche rince-pieds S03
Grifo mural con ducha lava pies S03
Wasserhahn für Wandmontage, mit Fußbrause S03

W10.FS.L/MX

- W10.FS.L/BX
- W10.FS.L/MB
- W10.FS.L/RL
- W10.FS.L/BB
- W10.FS.L/BC
- W10.FS.L/AB
- W10.FS.L/DB

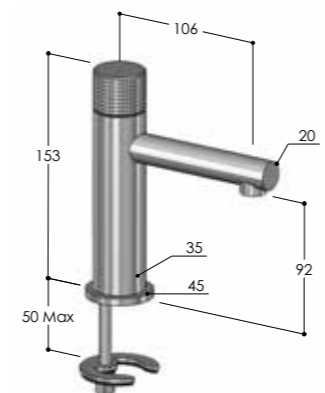

W35.M

Rubinetto acqua fredda
Cold water tap
Robinet eau froide
Grifo agua fria
Kaltwasserhahn

W35.M/MX

- W35.M/BX
- W35.M/MB
- W35.M/RL
- W35.M/BB
- W35.M/BC
- W35.M/AB
- W35.M/DB



COL30



Colonna con rubinetto d'arresto (altezza 80cm)
 Column with stop tap (height 80cm)
 Colonne avec robinet d'arrêt (hauteur 80cm)
 Columna con grifo (altura 80cm)
 Säule mit Wasserhahn (Höhe 80 cm)

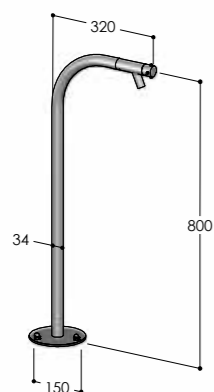

COL30/MX

- COL30/BX
- COL30/MB
- COL30/RL

COL30.H



Colonna con rubinetto d'arresto (altezza 120cm)
 Column with stop tap (height 120cm)
 Colonne avec robinet d'arrêt (hauteur 120cm)
 Columna con grifo (altura 120cm)
 Säule mit Wasserhahn (Höhe 120 cm)

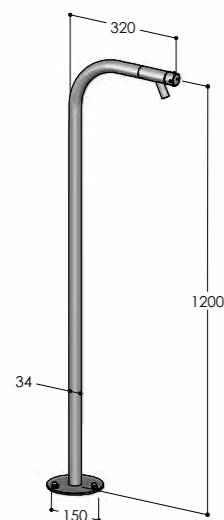

COL30.H/MX

- COL30.H/BX
- COL30.H/MB
- COL30.H/RL

COL30.G



Colonna con rubinetto da giardino per installazione su terreno
 Column with garden tap for installation on ground
 Colonne avec robinet de jardin pour installation au sol
 Columna con grifo para jardín para instalación sobre tierra
 Säule mit Gartenhahn für Bodeneinbau

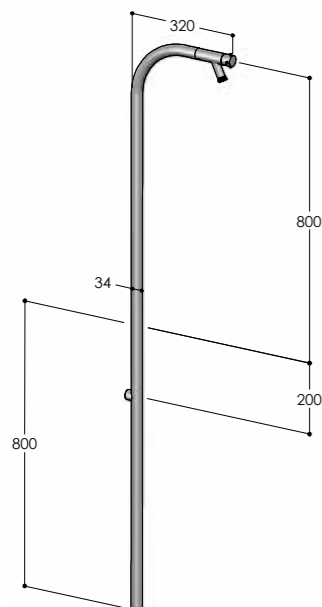

COL30.G/MX

- COL30.G/BX
- COL30.G/MB
- COL30.G/RL



COL90.R



Colonna con rubinetto acqua fredda
 Column with cold water tap
 Colonne avec robinet eau froide
 Columna con grifo agua fría
 Säule mit Kaltwasserhahn

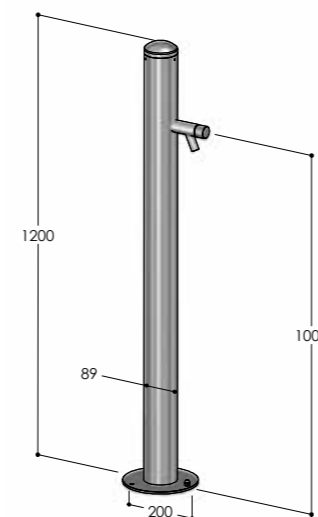

COL90.R/MX

- COL90.R/BX
- COL90.R/MB
- COL90.R/RL

Corpo incasso_Concealed body_Corps encastré_Cuerpo empotrado_UP-Teil (pag. 209)

CW.1

Parti esterne_External parts_Parties externes_Parties externas_AP-Teile

COL90.XCW.R/MX

- COL90.XCW.R/BX
- COL90.XCW.R/MB
- COL90.XCW.R/RL

COL90.4S.R/MX

- COL90.4S.R/BX
- COL90.4S.R/MB
- COL90.4S.R/RL

COL90



Colonna con rubinetto d'arresto e doccia
 Column with stop tap and handshower
 Colonne avec robinet d'arrêt et douchette
 Columna con grifo y teleducha
 Säule mit Wasserhahn und Handbrause

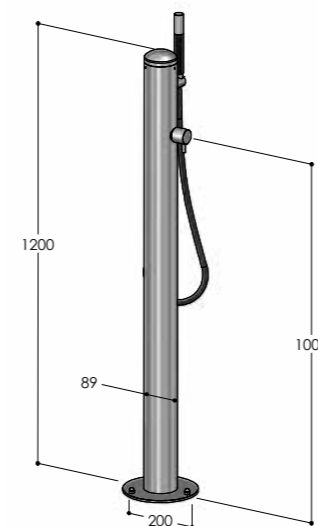

COL90/MX

- COL90/BX
- COL90/MB
- COL90/RL

Corpo incasso_Concealed body_Corps encastré_Cuerpo empotrado_UP-Teil (pag. 209)

CW.1

Parti esterne_External parts_Parties externes_Parties externas_AP-Teile

COL90.XCW/MX

- COL90.XCW/BX
- COL90.XCW/MB
- COL90.XCW/RL

COL90.4S/MX

- COL90.4S/BX
- COL90.4S/MB
- COL90.4S/RL

COL90.M



Colonna con miscelatore e doccia
 Column with mixer and handshower
 Colonne avec mitigeur et douchette
 Columna con monomando y teleducha
 Säule mit Einhebelmischer und Handbrause

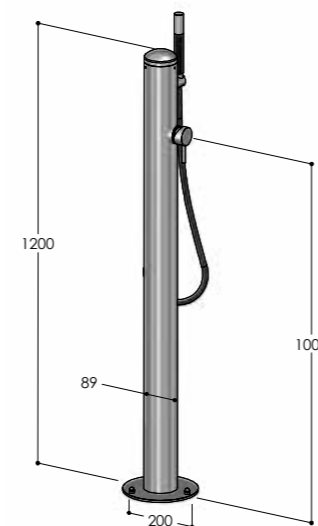

COL90.M/MX

- COL90.M/BX
- COL90.M/MB
- COL90.M/RL

Corpo incasso_Concealed body_Corps encastré_Cuerpo empotrado_UP-Teil (pag. 209)

CW.1

Parti esterne_External parts_Parties externes_Parties externas_AP-Teile

COL90.XCW.M/MX

- COL90.XCW.M/BX
- COL90.XCW.M/MB
- COL90.XCW.M/RL

COL90.4S.M/MX

- COL90.4S.M/BX
- COL90.4S.M/MB
- COL90.4S.M/RL

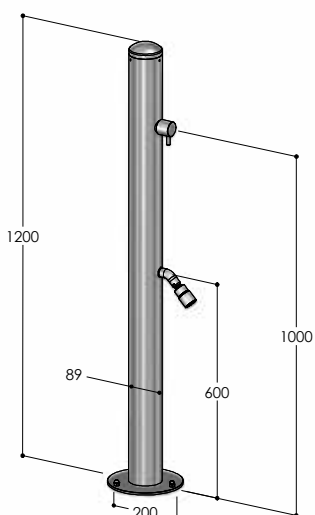

COL90.1

Colonna lavapiedi
 Footwash column
 Colonne rince-pieds
 Columna lava pies
 Fußbrause-Säule

✓	COL90.1/MX
	COL90.1/BX
	COL90.1/MB
CW	Corpo incasso_Concealed body_Corps encastré_Cuerpo empotrado_UP-Teil (pag. 209)
	CW.1
	Parti esterne_External parts_Parties externes_Parties externas_AP-Teile
4S	COL90.XCW.1/MX
	COL90.XCW.1/BX
	COL90.XCW.1/MB
	COL90.XCW.1/RL

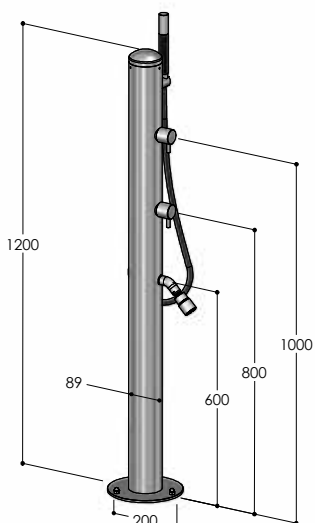

COL90.2

Colonna con 2 rubinetti d'arresto, doccia e lavapiedi
 Column with 2 stop taps, handshower and footwash
 Colonne avec 2 robinets d'arrêt, douchette et rince-pieds
 Columna con 2 grifos, teleducha y lava pies
 Säule mit 2 Wasserhähnen, Handbrause und Fußbrause

✓	COL90.2/MX
	COL90.2/BX
	COL90.2/MB
CW	Corpo incasso_Concealed body_Corps encastré_Cuerpo empotrado_UP-Teil (pag. 209)
	CW.1
	Parti esterne_External parts_Parties externes_Parties externas_AP-Teile
4S	COL90.XCW.2/MX
	COL90.XCW.2/BX
	COL90.XCW.2/MB
	COL90.XCW.2/RL



COMMUNITY

Shower
Pool
Garden



COMMUNITY

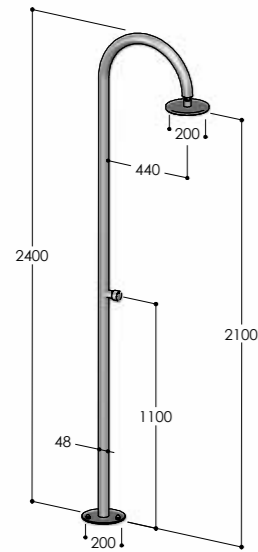

C50AS.AST

Colonna doccia con rubinetto temporizzato e soffione S06
 Shower column with time-limited self-closing tap and S06 showerhead
 Colonne douche avec robinet temporisé et pomme de douche S06
 Columna de ducha con grifo temporizado y rociador S06
 Duschsäule, selbstschließendem Hahn und Kopfbrause S06

✓	C50AS.AST/MX C50AS.AST/BX C50AS.AST/MB C50AS.AST/RL
	Corpo incasso_Concealed body_Corps encastré_Cuerpo empotrado_UP-Teil (pag. 209)
	CW.1
CW	Parti esterne_External parts_Parties externes_Parties externas_AP-Teile C50AS.XCW.AST/MX C50AS.XCW.AST/BX C50AS.XCW.AST/MB C50AS.XCW.AST/RL
EW	C50AS.EW.AST/MX C50AS.EW.AST/BX C50AS.EW.AST/MB C50AS.EW.AST/RL

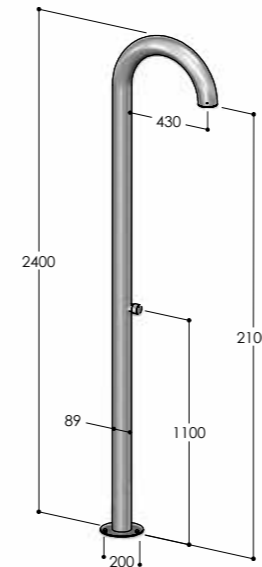

C90.AST

Colonna doccia con rubinetto temporizzato e soffione incassato
 Shower column with time-limited self-closing tap and concealed showerhead
 Colonne douche avec robinet temporisé et pomme de douche intégrée
 Columna de ducha con grifo temporizado y rociador integrado
 Duschsäule, selbstschließendem Hahn und integrierter Kopfbrause

✓	C90.AST/MX C90.AST/BX C90.AST/MB C90.AST/RL
	Corpo incasso_Concealed body_Corps encastré_Cuerpo empotrado_UP-Teil (pag. 209)
	CW.1
CW	Parti esterne_External parts_Parties externes_Parties externas_AP-Teile C90.XCW.AST/MX C90.XCW.AST/BX C90.XCW.AST/MB C90.XCW.AST/RL
EW	C90.EW.AST/MX C90.EW.AST/BX C90.EW.AST/MB C90.EW.AST/RL
4S	C90.4S.AST/MX C90.4S.AST/BX C90.4S.AST/MB C90.4S.AST/RL

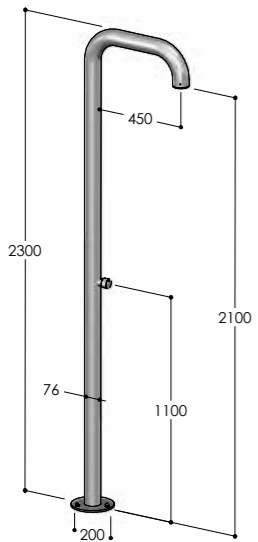

B76.AST

Colonna doccia con rubinetto temporizzato e soffione incassato
 Shower column with time-limited self-closing tap and concealed showerhead
 Colonne douche avec robinet temporisé et pomme de douche intégrée
 Columna de ducha con grifo temporizado y rociador integrado
 Duschsäule, selbstschließendem Hahn und integrierter Kopfbrause

✓	B76.AST/MX B76.AST/BX B76.AST/MB B76.AST/RL
	Corpo incasso_Concealed body_Corps encastré_Cuerpo empotrado_UP-Teil (pag. 209)
	CW.1
CW	Parti esterne_External parts_Parties externes_Parties externas_AP-Teile B76.XCW.AST/MX B76.XCW.AST/BX B76.XCW.AST/MB B76.XCW.AST/RL
EW	B76.EW.AST/MX B76.EW.AST/BX B76.EW.AST/MB B76.EW.AST/RL
4S	B76.4S.AST/MX B76.4S.AST/BX B76.4S.AST/MB B76.4S.AST/RL

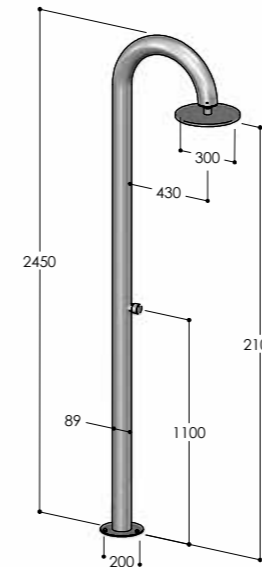

CL90.AST

Colonna doccia con rubinetto temporizzato e soffione S10
 Shower column with time-limited self-closing tap and S10 showerhead
 Colonne douche avec robinet temporisé et pomme de douche S10
 Columna de ducha con grifo temporizado y rociador S10
 Duschsäule, selbstschließendem Hahn und Kopfbrause S10

✓	CL90.AST/MX CL90.AST/BX CL90.AST/MB CL90.AST/RL
	Corpo incasso_Concealed body_Corps encastré_Cuerpo empotrado_UP-Teil (pag. 209)
	CW.1
CW	Parti esterne_External parts_Parties externes_Parties externas_AP-Teile CL90.XCW.AST/MX CL90.XCW.AST/BX CL90.XCW.AST/MB CL90.XCW.AST/RL
EW	CL90.EW.AST/MX CL90.EW.AST/BX CL90.EW.AST/MB CL90.EW.AST/RL
4S	CL90.4S.AST/MX CL90.4S.AST/BX CL90.4S.AST/MB CL90.4S.AST/RL

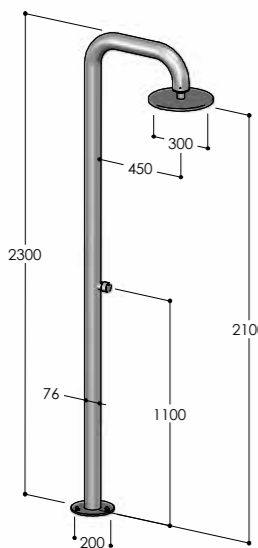

BW76.AST

Colonna doccia con rubinetto temporizzato e soffione S10
 Shower column with time-limited self-closing tap and S10 showerhead
 Colonne douche avec robinet temporisé et pomme de douche S10
 Columna de ducha con grifo temporizado y rociador S10
 Duschsäule, selbstschließendem Hahn und Kopfbrause S10

✓	BW76.AST/MX BW76.AST/BX BW76.AST/MB BW76.AST/RL
	Corpo incasso_Concealed body_Corps encastré_Cuerpo empotrado_UP-Teil (pag. 209)
	CW.1
CW	Parti esterne_External parts_Parties externes_Parties externas_AP-Teile BW76.XCW.AST/MX BW76.XCW.AST/BX BW76.XCW.AST/MB BW76.XCW.AST/RL
EW	BW76.EW.AST/MX BW76.EW.AST/BX BW76.EW.AST/MB BW76.EW.AST/RL
4S	BW76.4S.AST/MX BW76.4S.AST/BX BW76.4S.AST/MB BW76.4S.AST/RL

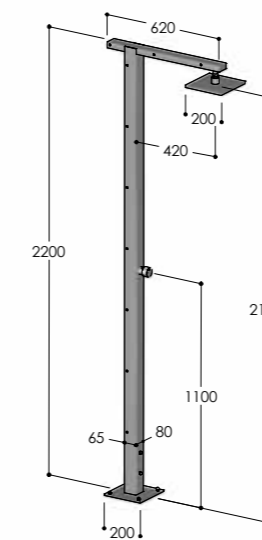

Q86.AST

Colonna doccia con rubinetto temporizzato e soffione S07
 Shower column with time-limited self-closing tap and S07 showerhead
 Colonne douche avec robinet temporisé et pomme de douche S07
 Columna de ducha con grifo temporizado y rociador S07
 Duschsäule, selbstschließendem Hahn und Kopfbrause S07

✓	Q86.AST/MX Q86.AST/BX
	Corpo incasso_Concealed body_Corps encastré_Cuerpo empotrado_UP-Teil (pag. 209)
	CW.1
CW	Parti esterne_External parts_Parties externes_Parties externas_AP-Teile Q86.XCW.AST/MX Q86.XCW.AST/BX

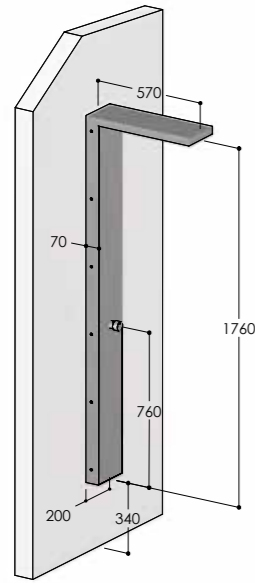

P22.AST

Pannello doccia murale con rubinetto temporizzato e soffione incassato
 Wall-mounted shower panel with time-limited self-closing tap and concealed showerhead
 Colonne douche mural avec robinet temporisé et pomme de douche intégrée
 Panel de ducha mural con grifo temporizado y rociador integrado
 Duschpaneel, selbstschließendem Hahn und integrierter Kopfbrause

P22.AST/MX
 P22.AST/BX

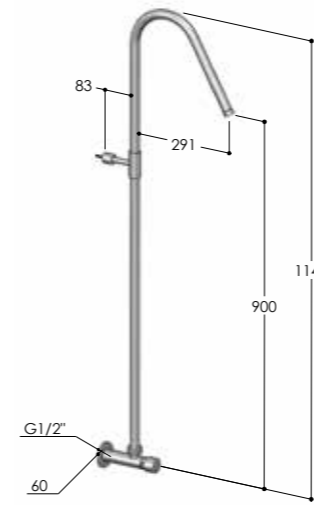

W88.AST

Rubinetto esterno temporizzato con colonna doccia e soffione incassato
 Wall-mounted time-limited self-closing tap with column and concealed showerhead
 Robinet temporisé mural avec colonne et pomme de douche intégrée
 Grifo temporizado mural con columna y rociador integrado
 Selbstschließendem Hahn mit Stange und integrierter Kopfbrause

W88.AST/MX
 W88.AST/BX
 W88.AST/MB
 W88.AST/RL
 W88.AST/BB
 W88.AST/BC
 W88.AST/AB
 W88.AST/DB

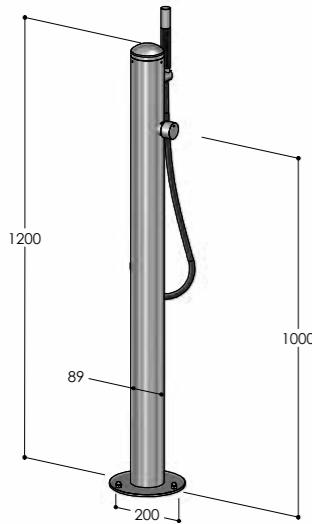

COL90.AST

Colonna con rubinetto temporizzato e doccetta
 Column with time-limited self-closing tap and handshower
 Colonne avec robinet temporisé et douchette
 Columna con grifo temporizado y teleducha
 Säule mit selbstschließendem Hahn und Handbrause

✓	COL90.AST/MX COL90.AST/BX COL90.AST/MB COL90.AST/RL
	Corpo incasso_Concealed body_Corps encastré_Cuerpo empotrado_UP-Teil (pag. 209)
	CW.1
CW	Parti esterne_External parts_Parties externes_Parties externas_AP-Teile COL90.XCW.AST/MX COL90.XCW.AST/BX COL90.XCW.AST/MB COL90.XCW.AST/RL
4S	COL90.4S.AST/MX COL90.4S.AST/BX COL90.4S.AST/MB COL90.4S.AST/RL

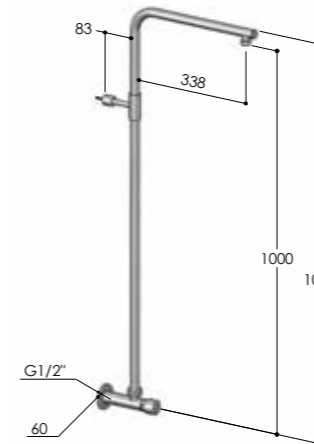

W78.AST

Rubinetto esterno temporizzato con colonna doccia e soffione incassato
 Wall-mounted time-limited self-closing tap with column and concealed showerhead
 Robinet temporisé mural avec colonne et pomme de douche intégrée
 Grifo temporizado mural con columna y rociador integrado
 Selbstschließendem Hahn mit Stange und integrierter Kopfbrause

W78.AST/MX
 W78.AST/BX
 W78.AST/MB
 W78.AST/RL
 W78.AST/BB
 W78.AST/BC
 W78.AST/AB
 W78.AST/DB

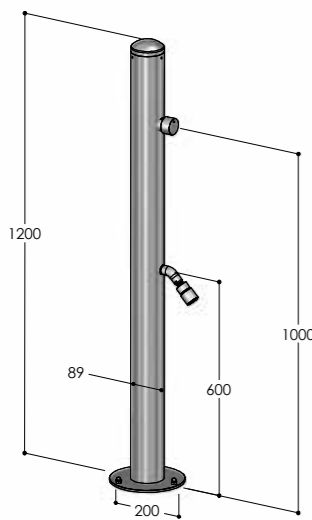

COL90.AST.L

Colonna con rubinetto temporizzato e lavapiedi
 Column with time-limited self-closing tap and footwash
 Colonne avec robinet temporisé et rince-pieds
 Columna con grifo temporizado y lava pies
 Säule mit selbstschließendem Hahn und Fußbrause

✓	COL90.AST.L/MX COL90.AST.L/BX COL90.AST.L/MB COL90.AST.L/RL
	Corpo incasso_Concealed body_Corps encastré_Cuerpo empotrado_UP-Teil (pag. 209)
	CW.1
CW	Parti esterne_External parts_Parties externes_Parties externas_AP-Teile COL90.XCW.AST.L/MX COL90.XCW.AST.L/BX COL90.XCW.AST.L/MB COL90.XCW.AST.L/RL
4S	COL90.4S.AST.L/MX COL90.4S.AST.L/BX COL90.4S.AST.L/MB COL90.4S.AST.L/RL

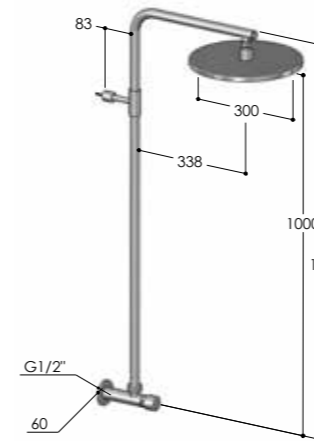

W68.AST

Rubinetto esterno temporizzato con colonna doccia e soffione S10
 Wall-mounted time-limited self-closing tap with column and S10 showerhead
 Robinet temporisé mural avec colonne et pomme de douche S10
 Grifo temporizado mural con columna y rociador S10
 Selbstschließendem Hahn mit Stange und S10 Kopfbrause

W68.AST/MX
 W68.AST/BX
 W68.AST/MB
 W68.AST/RL
 W68.AST/BB
 W68.AST/BC
 W68.AST/AB
 W68.AST/DB

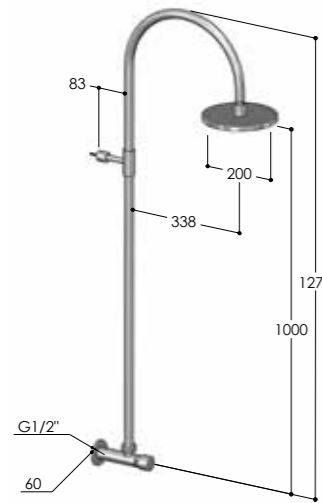

W98.AST

Rubinetto esterno temporizzato con colonna doccia e soffione S06
 Wall-mounted time-limited self-closing tap with column and S06 showerhead
 Robinet temporisé mural avec colonne et pomme de douche S06
 Grifo temporizado mural con columna y rociador S06
 Selbstschließendem Hahn mit Stange und S06 Kopfbrause

W98.AST/MX

- W98.AST/BX
- W98.AST/MB
- W98.AST/RL
- W98.AST/BB
- W98.AST/BC
- W98.AST/AB
- W98.AST/DB

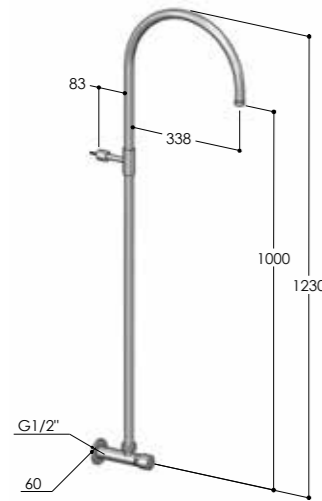

W18.AST

Rubinetto esterno temporizzato con colonna doccia e soffione incassato
 Wall-mounted time-limited self-closing tap with column and concealed showerhead
 Robinet temporisé mural avec colonne et pomme de douche intégrée
 Grifo temporizado mural con columna y rociador integrado
 Selbstschließendem Hahn mit Stange und integrierter Kopfbrause

W18.AST/MX

- W18.AST/BX
- W18.AST/MB
- W18.AST/RL
- W18.AST/BB
- W18.AST/BC
- W18.AST/AB
- W18.AST/DB

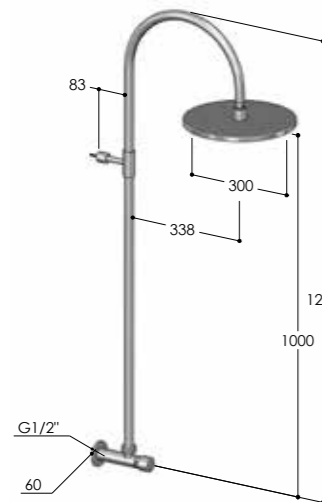

W28.AST

Rubinetto esterno temporizzato con colonna doccia e soffione S10
 Wall-mounted time-limited self-closing tap with column and S10 showerhead
 Robinet temporisé mural avec colonne et pomme de douche S10
 Grifo temporizado mural con columna y rociador S10
 Selbstschließendem Hahn mit Stange und S10 Kopfbrause

W28.AST/MX

- W28.AST/BX
- W28.AST/MB
- W28.AST/RL
- W28.AST/BB
- W28.AST/BC
- W28.AST/AB
- W28.AST/DB

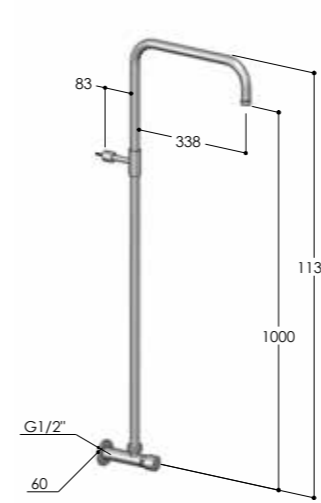

W38.AST

Rubinetto esterno temporizzato con colonna doccia e soffione incassato
 Wall-mounted time-limited self-closing tap with column and concealed showerhead
 Robinet temporisé mural avec colonne et pomme de douche intégrée
 Grifo temporizado mural con columna y rociador integrado
 Selbstschließendem Hahn mit Stange und integrierter Kopfbrause

W38.AST/MX

- W38.AST/BX
- W38.AST/MB
- W38.AST/RL
- W38.AST/BB
- W38.AST/BC
- W38.AST/AB
- W38.AST/DB

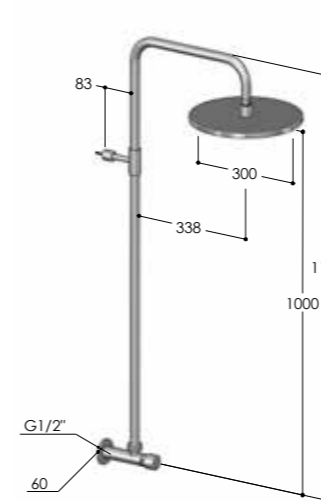

W48.AST

Rubinetto esterno temporizzato con colonna doccia e soffione S10
 Wall-mounted time-limited self-closing tap with column and S10 showerhead
 Robinet temporisé mural avec colonne et pomme de douche S10
 Grifo temporizado mural con columna y rociador S10
 Selbstschließendem Hahn mit Stange und S10 Kopfbrause

W48.AST/MX

- W48.AST/BX
- W48.AST/MB
- W48.AST/RL
- W48.AST/BB
- W48.AST/BC
- W48.AST/AB
- W48.AST/DB

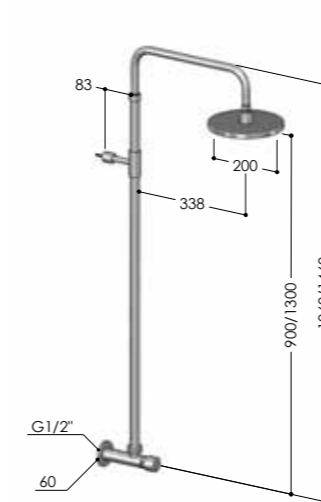

W08.AST

Rubinetto esterno temporizzato con colonna doccia e soffione S06
 Wall-mounted time-limited self-closing tap with column and S06 showerhead
 Robinet temporisé mural avec colonne et pomme de douche S06
 Grifo temporizado mural con columna y rociador S06
 Selbstschließendem Hahn mit Stange und S06 Kopfbrause

W08.AST/MX

- W08.AST/BX
- W08.AST/MB
- W08.AST/RL
- W08.AST/BB
- W08.AST/BC
- W08.AST/AB
- W08.AST/DB

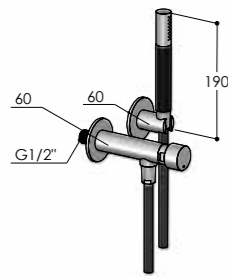

WX8.AST.SK

Rubinetto temporizzato con kit doccia
Time-limited self-closing wall-mounted tap with shower kit
Robinet mural temporisé avec kit de douche
Grifo mural temporizado con kit de ducha
Selbstschließendem Hahn für Wandmontage mit Brausekit

WX8.AST.SK/MX

- WX8.AST.SK/BX
- WX8.AST.SK/MB
- WX8.AST.SK/RL
- WX8.AST.SK/BB
- WX8.AST.SK/BC
- WX8.AST.SK/AB
- WX8.AST.SK/DB

W12.AST

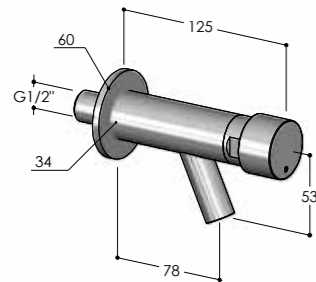

Rubinetto temporizzato a parete
Time-limited self-closing wall-mounted tap
Robinet mural temporisé
Grifo mural temporizado
Selbstschließendem Hahn für Wandmontage

W12.AST/MX

- W12.AST/BX
- W12.AST/MB
- W12.AST/RL
- W12.AST/BB
- W12.AST/BC
- W12.AST/AB
- W12.AST/DB

W12.AST.FS

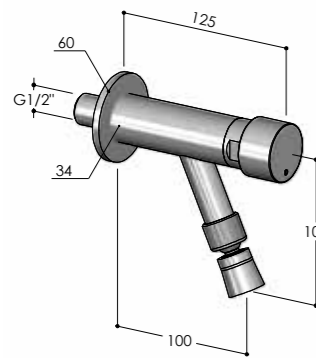

Rubinetto temporizzato a parete con soffione lavapiedi S03
Time-limited self-closing wall-mounted tap with foot shower S03
Robinet mural temporisé avec douchette rince-pieds S03
Grifo mural temporizado con lava pies S03
Selbstschließendem Hahn für Wandmontage mit Fußbrause S03

W12.AST.FS/MX

- W12.AST.FS/BX
- W12.AST.FS/MB
- W12.AST.FS/RL
- W12.AST.FS/BB
- W12.AST.FS/BC
- W12.AST.FS/AB
- W12.AST.FS/DB

W35.M.AST

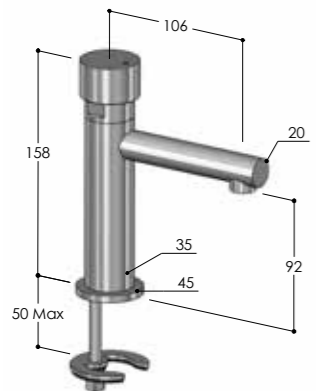

Rubinetto temporizzato da lavabo
Washbasin time-limited self-closing tap
Robinet temporisé de lavabo
Grifo temporizado de lavabo
Selbstschließendem Hahn für Waschtisch

W35.M.AST/MX

- W35.M.AST/BX
- W35.M.AST/MB
- W35.M.AST/RL
- W35.M.AST/BB
- W35.M.AST/BC
- W35.M.AST/AB
- W35.M.AST/DB

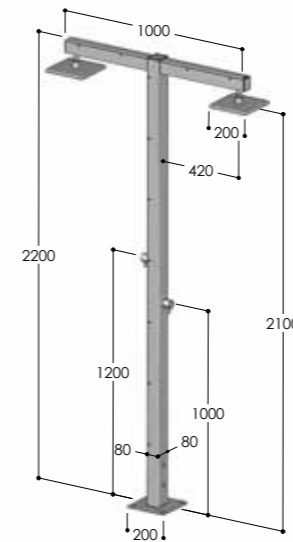

Q86.2

Colonna doccia da esterno con 2 rubinetti d'arresto e 2 soffioni S07
Outdoor shower column with 2 stop taps and 2 showerheads S07
Colonne douche d'extérieur avec 2 robinets d'arrêt et 2 pommes de douche S07
Columna de ducha para exterior con 2 grifos y 2 rociadores S07
Duschsäule für den Außenbereich mit 2 Wasserhähnen und 2 Kopfbrausen S07

- ✓ **Q86.2/MX**
- Q86.2/BX

Q86.AST.2

Colonna doccia da esterno con 2 rubinetti temporizzati e 2 soffioni S07
Outdoor shower column with 2 time-limited self-closing taps and 2 showerheads S07
Colonne douche d'extérieur avec 2 robinets temporisés et 2 pommes de douche S07
Columna de ducha para exterior con 2 grifos temporizados y 2 rociadores S07
Duschsäule für den Außenbereich mit 2 selbstschließendem Hähnen und 2 Kopfbrausen S07

- ✓ **Q86.AST.2/MX**
- Q86.AST.2/BX

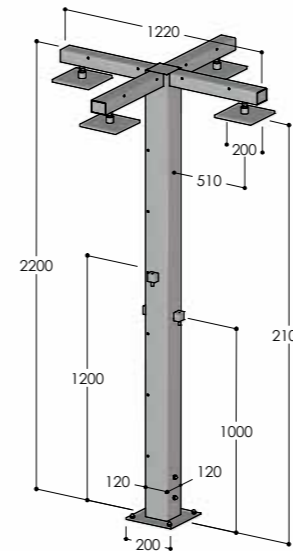

Q120

Colonna doccia da esterno con 4 rubinetti d'arresto e 4 soffioni S07
Outdoor shower column with 4 stop taps and 4 showerheads S07
Colonne douche d'extérieur avec 4 robinets d'arrêt et 4 pommes de douche S07
Columna de ducha para exterior con 4 grifos y 4 rociadores S07
Duschsäule für den Außenbereich mit 4 Wasserhähnen und 4 Kopfbrausen S07

- ✓ **Q120/MX**
- Q120/BX

Q120.AST

Colonna doccia da esterno con 4 rubinetti temporizzati e 4 soffioni S07
Outdoor shower column with 4 time-limited self-closing taps and 4 showerheads S07
Colonne douche d'extérieur avec 4 robinets temporisés et 4 pommes de douche S07
Columna de ducha para exterior con 4 grifos temporizados y 4 rociadores S07
Duschsäule für den Außenbereich mit 2 selbstschließendem Hähnen und 2 Kopfbrausen S07

- ✓ **Q120.AST/MX**
- Q120.AST/BX

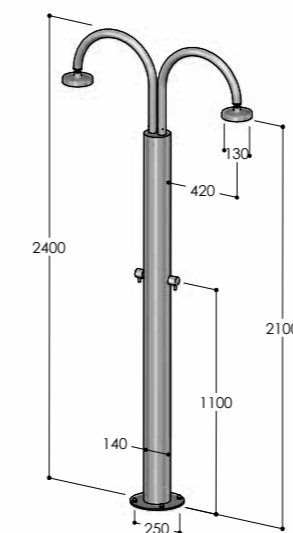

C140.2

Colonna doccia da esterno con 2 rubinetti d'arresto e 2 soffioni S02
Outdoor shower column with 2 stop taps and 2 showerheads S02
Colonne douche d'extérieur avec 2 robinets d'arrêt et 2 pommes de douche S02
Columna de ducha para exterior con 2 grifos y 2 rociadores S02
Duschsäule für den Außenbereich mit 2 Wasserhähnen und 2 Kopfbrausen S02

- ✓ **C140.2/MX**

C140.AST.2

Colonna doccia da esterno con 2 rubinetti temporizzati e 2 soffioni S02
Outdoor shower column with 2 time-limited self-closing taps and 2 showerheads S02
Colonne douche d'extérieur avec 2 robinets temporisés et 2 pommes de douche S02
Columna de ducha para exterior con 2 grifos temporizados y 2 rociadores S02
Duschsäule für den Außenbereich mit 2 selbstschließendem Hähnen und 2 Kopfbrausen S02

- ✓ **C140.AST.2/MX**

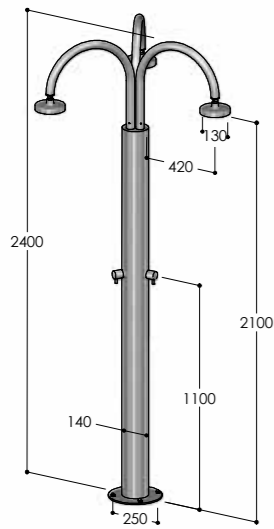

C140.3

Colonna doccia da esterno con 3 rubinetti d'arresto e 3 soffioni S02
 Outdoor shower column with 3 stop taps and 3 showerheads S02
 Colonne douche d'extérieur avec 3 robinets d'arrêt et 3 pommes de douche S02
 Columna de ducha para exterior con 3 grifos y 3 rociadores S02
 Duschsäule für den Außenbereich mit 3 Wasserhähnen und 3 Kopfbrausen S02

✓ **C140.3/MX**

C140.AST.3

Colonna doccia da esterno con 3 rubinetti temporizzati e 3 soffioni S02
 Outdoor shower column with 3 time-limited self-closing taps and 3 showerheads S02
 Colonne douche d'extérieur avec 3 robinets temporisés et 3 pommes de douche S02
 Columna de ducha para exterior con 3 grifos temporizados y 3 rociadores S02
 Duschsäule für den Außenbereich mit 3 selbstschließendem Hähnen und 3 Kopfbrausen S02

✓ **C140.AST.3/MX**

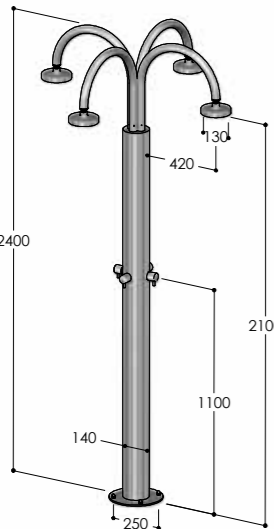

C140.4

Colonna doccia da esterno con 4 rubinetti d'arresto e 4 soffioni S02
 Outdoor shower column with 4 stop taps and 4 showerheads S02
 Colonne douche d'extérieur avec 4 robinets d'arrêt et 4 pommes de douche S02
 Columna de ducha para exterior con 4 grifos y 4 rociadores S02
 Duschsäule für den Außenbereich mit 4 Wasserhähnen und 4 Kopfbrausen S02

✓ **C140.4/MX**

C140.AST.4

Colonna doccia da esterno con 4 rubinetti temporizzati e 4 soffioni S02
 Outdoor shower column with 4 time-limited self-closing taps and 4 showerheads S02
 Colonne douche d'extérieur avec 4 robinets temporisés et 4 pommes de douche S02
 Columna de ducha para exterior con 4 grifos temporizados y 4 rociadores S02
 Duschsäule für den Außenbereich mit 4 selbstschließendem Hähnen und 4 Kopfbrausen S02

✓ **C140.AST.4/MX**

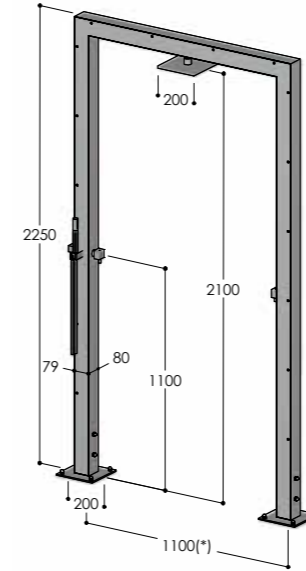

PQ80

Doccia a ponte con 2 rubinetti d'arresto, soffione S07 e doccia
 Shower bridge with 2 stop taps, showerhead S07 and handshower
 Portique douche avec 2 robinets d'arrêt, pomme de douche S07 et douchette
 Túnel ducha con 2 grifos, rociador S07 y teleducha
 Brücken-Duschsäule mit 2 Wasserhähnen, Kopfbrause S07 und Handbrause

Interasse su richiesta
 Center distance on request
 Entraxe sur requête
 Distancia a pedido
 Achsabstand auf Anfrage
 min 800 - max 1400 mm

✓ **PQ80/MX**
 PQ80/BX

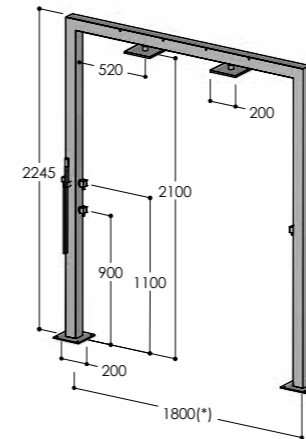

PQ80.2

Doccia a ponte con 3 rubinetti d'arresto, 2 soffioni S07 e doccia
 Shower bridge with 3 stop taps, 2 showerheads S07 and handshower
 Portique douche avec 3 robinets d'arrêt, 2 pommes de douche S07 et douchette
 Túnel ducha con 3 grifos, 2 rociadores mm S07 y teleducha
 Brücken-Duschsäule, mit 3 Wasserhähnen, 2 Kopfbrausen S07 und Handbrause

Interasse su richiesta
 Center distance on request
 Entraxe sur requête
 Distancia a pedido
 Achsabstand auf Anfrage
 min 1400 - max 2000 mm

✓ **PQ80.2/MX**
 PQ80.2/BX

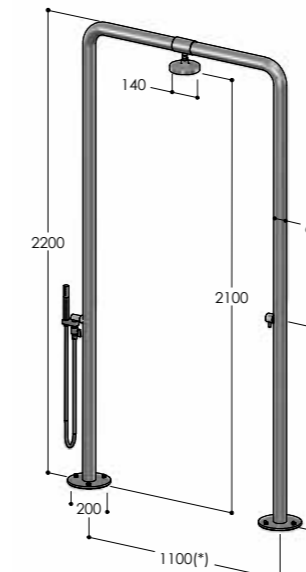

P60

Doccia a ponte con rubinetto d'arresto, soffione ABS S02 e doccia
 Shower bridge with stop tap, ABS showerhead S02 and handshower
 Portique douche avec robinet d'arrêt, pomme de douche ABS S02 et douchette
 Túnel ducha con grifo, rociador ABS S02 y teleducha
 Brücken-Duschsäule, mit Wasserhahn, ABS Kopfbrause S02 und Handbrause

Interasse su richiesta
 Center distance on request
 Entraxe sur requête
 Distancia a pedido
 Achsabstand auf Anfrage
 min 800 - max 1400 mm

✓ **P60/MX**



KITCHEN

- Sink Mixers *pag 170*
- Sink Mixers Pull-out *pag 173*
- Sink Mixers Pull-down *pag 174*





K35.L

Miscelatore da lavello con canna girevole
Sink mixer with swivel spout
Mitigeur d'évier avec bec mobile
Monomando de fregadero con caño rotatorio
Spültischmischer mit Schwenkauslauf

K35.L/MX

- K35.L/BX
- K35.L/MB
- K35.L/RL
- K35.L/BB
- K35.L/BC
- K35.L/AB
- K35.L/DB

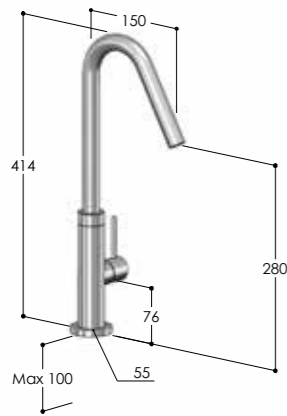

K35.Y

Miscelatore da lavello con canna girevole
Sink mixer with swivel spout
Mitigeur d'évier avec bec mobile
Monomando de fregadero con caño rotatorio
Spültischmischer mit Schwenkauslauf

K35.Y/MX

- K35.Y/BX
- K35.Y/MB
- K35.Y/RL
- K35.Y/BB
- K35.Y/BC
- K35.Y/AB
- K35.Y/DB

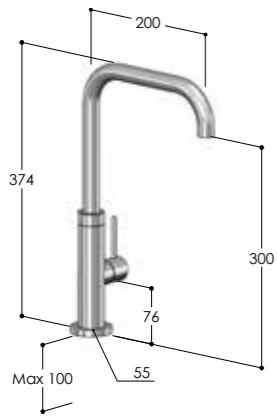

K35.CD

Miscelatore da lavello con canna girevole
Sink mixer with swivel spout
Mitigeur d'évier avec bec mobile
Monomando de fregadero con caño rotatorio
Spültischmischer mit Schwenkauslauf

K35.CD/MX

- K35.CD/BX
- K35.CD/MB
- K35.CD/RL
- K35.CD/BB
- K35.CD/BC
- K35.CD/AB
- K35.CD/DB



K35.O

Miscelatore da lavello con canna girevole
Sink mixer with swivel spout
Mitigeur d'évier avec bec mobile
Monomando de fregadero con caño rotatorio
Spültischmischer mit Schwenkauslauf

K35.O/MX

- K35.O/BX
- K35.O/MB
- K35.O/RL
- K35.O/BB
- K35.O/BC
- K35.O/AB
- K35.O/DB

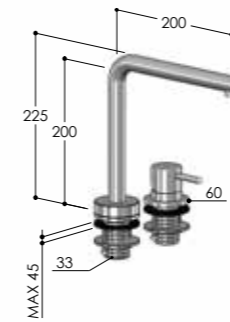

K2M.L

Batteria da lavello, con miscelatore e bocca girevole
Sink battery, with mixer and swivel spout
Batterie d'évier, avec mitigeur et bec mobile
Monomando de cocina de 2 agujeros, con caño giratorio
Spültisch-Zweiloch-Batterie, mit Mischer und Schwenkauslauf

K2M.L/MX

- K2M.L/BX
- K2M.L/MB
- K2M.L/RL
- K2M.L/BB
- K2M.L/BC
- K2M.L/AB
- K2M.L/DB



K2M.Y

Batteria da lavello, con miscelatore e bocca girevole
Sink battery, with mixer and swivel spout
Batterie d'évier, avec mitigeur et bec mobile
Monomando de cocina de 2 agujeros, con caño giratorio
Spültisch-Zweiloch-Batterie, mit Mischer und Schwenkauslauf

K2M.Y/MX

- K2M.Y/BX
- K2M.Y/MB
- K2M.Y/RL
- K2M.Y/BB
- K2M.Y/BC
- K2M.Y/AB
- K2M.Y/DB

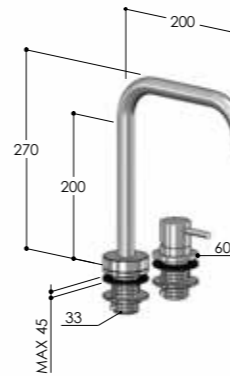

K2M.CD

Batteria da lavello, con miscelatore e bocca girevole
Sink battery, with mixer and swivel spout
Batterie d'évier, avec mitigeur et bec mobile
Monomando de cocina de 2 agujeros, con caño giratorio
Spültisch-Zweiloch-Batterie, mit Mischer und Schwenkauslauf

K2M.CD/MX

- K2M.CD/BX
- K2M.CD/MB
- K2M.CD/RL
- K2M.CD/BB
- K2M.CD/BC
- K2M.CD/AB
- K2M.CD/DB



K2M.O

Batteria da lavello, con miscelatore e bocca girevole
Sink battery, with mixer and swivel spout
Batterie d'évier, avec mitigeur et bec mobile
Monomando de cocina de 2 agujeros, con caño giratorio
Spültisch-Zweiloch-Batterie, mit Mischer und Schwenkauslauf

K2M.O/MX

- K2M.O/BX
- K2M.O/MB
- K2M.O/RL
- K2M.O/BB
- K2M.O/BC
- K2M.O/AB
- K2M.O/DB

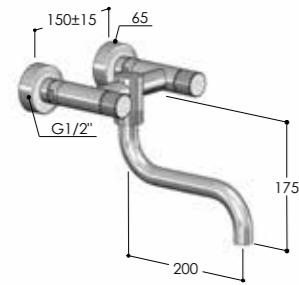

KW50

Gruppo da lavello a parete con bocca girevole
 Wall-mounted sink mixer with swivel spout
 Mélangeur d'évier mural avec bec mobile
 Bateria de pared para fregadero con caño rotatorio
 AP-Spültischbatterie mit Schwenkauslauf

KW50/MX

- _____ KW50/BX
- _____ KW50/MB
- _____ KW50/RL
- _____ KW50/BB
- _____ KW50/BC
- _____ KW50/AB
- _____ KW50/DB

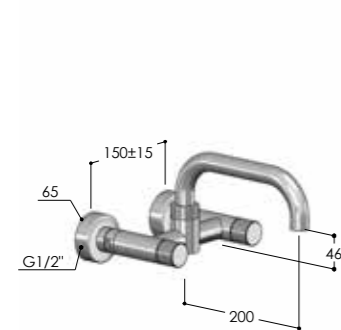

KW50.UP

Gruppo da lavello a parete con bocca girevole
 Wall-mounted sink mixer with swivel spout
 Mélangeur d'évier mural avec bec mobile
 Bateria de pared para fregadero con caño rotatorio
 AP-Spültischbatterie mit Schwenkauslauf

KW50.UP/MX

- _____ KW50.UP/BX
- _____ KW50.UP/MB
- _____ KW50.UP/RL
- _____ KW50.UP/BB
- _____ KW50.UP/BC
- _____ KW50.UP/AB
- _____ KW50.UP/DB

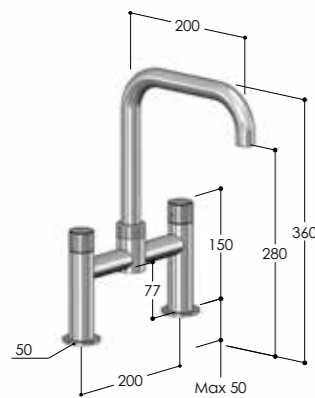

KW30

Gruppo da lavello a ponte con bocca girevole
 Sink mixer with swivel spout
 Mélangeur d'évier à pont avec bec mobile
 Bateria de fregadero con caño rotatorio
 Spültischbatterie mit Schwenkauslauf

KW30/MX

- _____ KW30/BX
- _____ KW30/MB
- _____ KW30/RL
- _____ KW30/BB
- _____ KW30/BC
- _____ KW30/AB
- _____ KW30/DB



K35.S

Miscelatore da lavello con doccia Pull-out a doppio getto
 Sink mixer with Pull-out dual-spray handshower
 Mitigeur d'évier avec douchette Pull-out à deux jets
 Monomando de fregadero con ducha extraíble Pull-out doble función
 Spültischmischer mit Pull-out Zwei-Strahl-Handbrause

K35.S/MX

- _____ K35.S/BX
- _____ K35.S/MB
- _____ K35.S/RL
- _____ K35.S/BB
- _____ K35.S/BC
- _____ K35.S/AB
- _____ K35.S/DB



K40.LS

Miscelatore da lavello con doccia Pull-out a doppio getto
 Sink mixer with Pull-out dual-spray handshower
 Mitigeur d'évier avec douchette Pull-out à deux jets
 Monomando de fregadero con ducha extraíble Pull-out doble función
 Spültischmischer mit Pull-out Zwei-Strahl-Handbrause

K40.LS/MX

- _____ K40.LS/BX
- _____ K40.LS/MB
- _____ K40.LS/RL
- _____ K40.LS/BB
- _____ K40.LS/BC
- _____ K40.LS/AB
- _____ K40.LS/DB



K40.OS

Miscelatore da lavello con doccia Pull-out a doppio getto
 Sink mixer with Pull-out dual-spray handshower
 Mitigeur d'évier avec douchette Pull-out à deux jets
 Monomando de fregadero con ducha extraíble Pull-out doble función
 Spültischmischer mit Pull-out Zwei-Strahl-Handbrause

K40.OS/MX

- _____ K40.OS/BX
- _____ K40.OS/MB
- _____ K40.OS/RL
- _____ K40.OS/BB
- _____ K40.OS/BC
- _____ K40.OS/AB
- _____ K40.OS/DB

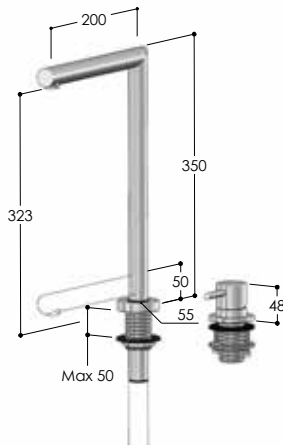

K2M.LT



Batteria da lavello, con miscelatore e bocca abbattibile

Sink battery, with mixer and pull down spout

Batterie d'évier, avec mitigeur et bec abattable

Monomando de cocina de 2 agujeros, con caño retráctil

Spültisch-Zweiloch-Batterie, mit Mischer und versenkbarem Auslauf

K2M.LT/MX

K2M.LT/BX

K2M.LT/MB

K2M.LT/RL

K2M.LT/BB

K2M.LT/BC

K2M.LT/AB

K2M.LT/DB



K2M.LTS



Miscelatore da lavello, con bocca abbattibile e doccia Pull-out a doppio getto

Sink mixer, with pull down spout and Pull-out dual-spray hand shower

Mitigeur d'évier, avec bec abattable et douche Pull-out à deux-jets

Monomando de cocina, con caño retráctil y ducha Pull-out 2 jet

Spültischmischer, mit versenkbarem Auslauf und Pull-out zwei-Strahl Handbrause

K2M.LTS/MX

K2M.LTS/BX

K2M.LTS/MB

K2M.LTS/RL

K2M.LTS/BB

K2M.LTS/BC

K2M.LTS/AB

K2M.LTS/DB

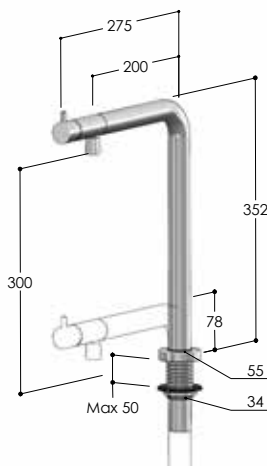

K1M.LT



Miscelatore da lavello abbattibile

Pull down sink mixer

Mitigeur d'évier abattable

Monomando de cocina retráctil

Pull-down Spültischmischer

K1M.LT/MX

K1M.LT/BX

K1M.LT/MB

K1M.LT/RL

K1M.LT/BB

K1M.LT/BC

K1M.LT/AB

K1M.LT/DB



WATERLINE

In-Wall	<i>pag. 176</i>
Shower	<i>pag. 179</i>
Shower kit	<i>pag. 182</i>
Rainshower	<i>pag. 184</i>



WATERLINE

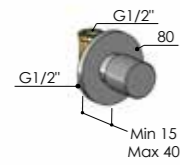

ST1

Rubinetto da incasso
Concealed tap
Robinet d'arrêt encastrable
Llave de paso
UP-Ventil

ST1/MX
ST1/BX

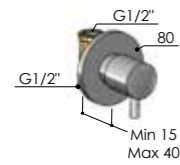

ST1.L

Rubinetto da incasso
Concealed tap
Robinet d'arrêt encastrable
Llave de paso
UP-Ventil

ST1.L/MX
ST1.L/BX

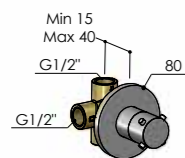

D3

Deviatore da incasso a 3 vie
3-ways Concealed diverter
Inverseur encastrable 3-voies
Desviador empotrado 3 salidas
3-Wege UP-Umsteller



D3/MX
D3/BX

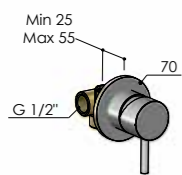

MRL

Miscelatore da lavabo
Washbasin mixer
Mitigeur de lavabo
Monomando lavabo
Waschtischmischer

MRL/MX
MRL/BX

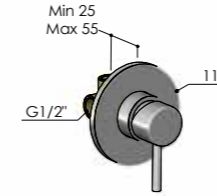

MR1

Miscelatore da incasso per doccia
Concealed shower mixer
Mitigeur de douche encastrable
Monomando empotrado para ducha
UP-Brausemischer

MR1/MX
MR1/BX

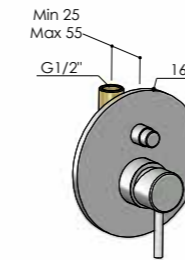

MR2

Miscelatore da incasso per doccia con deviatore automatico a 2 vie
Concealed shower mixer with 2-ways automatic diverter
Mitigeur de douche encastrable avec inverseur automatique à 2 voies
Monomando empotrado para ducha con desviador automatico 2 salidas
UP-Brausemischer mit 2-Wege automatischer Umsteller



MR2/MX
MR2/BX

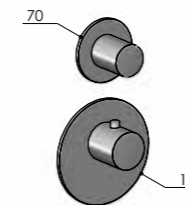

TC.HF1

Miscelatore termostatico da incasso per doccia, High-Flow
Concealed thermostatic mixer for shower, High-Flow
Mitigeur thermostatique de douche, High-Flow
Mezclador termostatico empotrado para ducha, High-Flow
UP-Thermostat-Brausemischer, High-Flow



Corpo incasso_Concealed body_Corps encastré_Cuerpo empotrado_UP-Teil (pag. 209)
HF1.INC

Parti esterne_External parts_Parties externes_Parties externas_AP-Teile

TC.HF1/MX

TC.HF1/BX
TC.HF1/MB
TC.HF1/RL
TC.HF1/BB
TC.HF1/BC
TC.HF1/AB
TC.HF1/DB

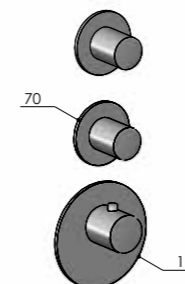

TC.HF2

Miscelatore termostatico da incasso per doccia a 2 vie, High Flow
2-ways concealed thermostatic mixer for shower, High-Flow
Mitigeur thermostatique de douche à 2-voies, High-Flow
Mezclador termostatico empotrado para ducha 2-salidas, High-Flow
2-Wege UP-Thermostat-Brausemischer, High-Flow



Corpo incasso_Concealed body_Corps encastré_Cuerpo empotrado_UP-Teil (pag. 209)
HF2.INC

Parti esterne_External parts_Parties externes_Parties externas_AP-Teile

TC.HF2/MX

TC.HF2/BX
TC.HF2/MB
TC.HF2/RL
TC.HF2/BB
TC.HF2/BC
TC.HF2/AB
TC.HF2/DB

TC.HF3



Miscelatore termostatico da incasso per doccia a 3 vie, High Flow
 3-ways concealed thermostatic mixer for shower, High-Flow
 Mitigeur thermostatique de douche à 3-voies, High-Flow
 Mezclador termostatico empotrado para ducha 3-salidas, High-Flow
 3-Wege UP-Thermostat-Brausemischer, High-Flow

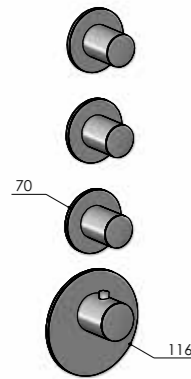

Corpo incasso_Concealed body_Corps encastré_Cuerpo empotrado_UP-Teil (pag. 209)

HF3.INC

Parti esterne_External parts_Parties externes_Parties externas_AP-Teile

TC.HF3/MX

- TC.HF3/BX
- TC.HF3/MB
- TC.HF3/RL
- TC.HF3/BB
- TC.HF3/BC
- TC.HF3/AB
- TC.HF3/DB

TC.HF4



Miscelatore termostatico da incasso per doccia a 4 vie, High Flow
 4-ways concealed thermostatic mixer for shower, High-Flow
 Mitigeur thermostatique de douche à 4 voies, High-Flow
 Mezclador termostatico empotrado para ducha 4-salidas, High-Flow
 4-Wege UP-Thermostat-Brausemischer, High-Flow

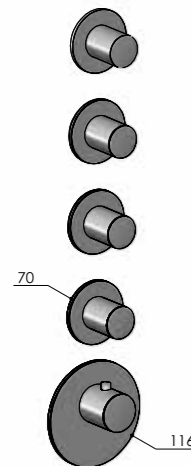

Corpo incasso_Concealed body_Corps encastré_Cuerpo empotrado_UP-Teil (pag. 209)

HF4.INC

Parti esterne_External parts_Parties externes_Parties externas_AP-Teile

TC.HF4/MX

- TC.HF4/BX
- TC.HF4/MB
- TC.HF4/RL
- TC.HF4/BB
- TC.HF4/BC
- TC.HF4/AB
- TC.HF4/DB

W010

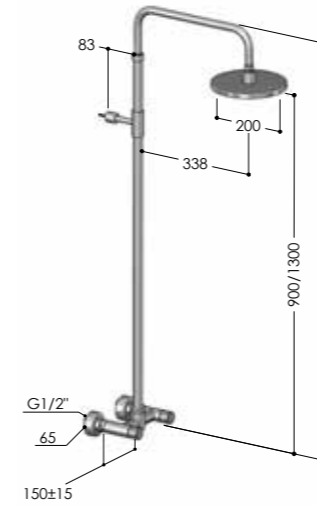

Gruppo esterno con colonna doccia e soffione 200 mm S06
 Wall-mounted shower mixer, with column and 200 mm showerhead S06
 Mélangeur douche avec colonne et pomme de douche 200 mm S06
 Batería para ducha con columna y rociador 200 mm S06
 AP-Brausebatterie mit Stange und 200 mm Kopfbrause S06

W010/MX

- W010/BX
- W010/MB
- W010/RL
- W010/BB
- W010/BC
- W010/AB
- W010/DB

W010.E

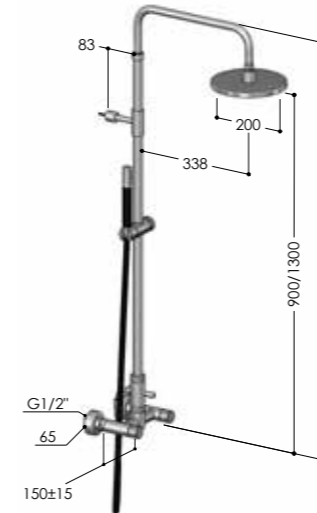

Gruppo esterno con colonna doccia, soffione 200 mm S06 e doccia
 Wall-mounted shower mixer, with column, 200 mm showerhead S06 and handshower
 Mélangeur douche avec colonne, pomme de douche 200 mm S06 et douchette
 Batería para ducha con columna, rociador 200 mm S06 y teleducha
 AP-Brausebatterie mit Stange, 200 mm Kopfbrause S06 und Handbrause

W010.E/MX

- W010.E/BX
- W010.E/MB
- W010.E/RL
- W010.E/BB
- W010.E/BC
- W010.E/AB
- W010.E/DB

W0X1

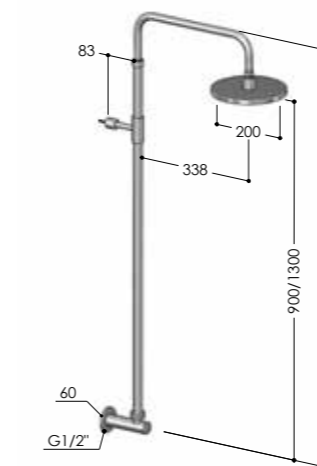

Presà d'acqua con colonna doccia e soffione 200 mm S06
 Wall coupling, with column and 200 mm showerhead S06
 Coude de sortie, avec colonne et pomme de douche 200 mm S06
 Codo mural, con columna y rociador 200 mm S06
 Wandanschlußbogen mit Stange und 200 mm Kopfbrause S06

W0X1/MX

- W0X1/BX
- W0X1/MB
- W0X1/RL
- W0X1/BB
- W0X1/BC
- W0X1/AB
- W0X1/DB

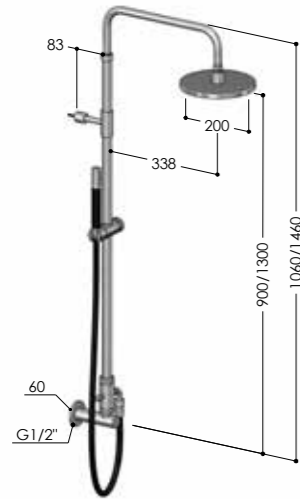

WOX1.E



Preso d'acqua con colonna doccia, soffione 200 mm S06 e doccia
 Wall coupling, with column, 200 mm showerhead S06 and handshower
 Coude de sortie avec colonne, pomme de douche 200 mm S06 et douchette
 Codo mural con columna, rociador 200 mm S06 y teleducha
 Wandanschlußbogen mit Stange, 200 mm Kopfbrause S06 und Handbrause

WOX1.E/MX

- WOX1.E/BX
- WOX1.E/MB
- WOX1.E/RL
- WOX1.E/BB
- WOX1.E/BC
- WOX1.E/AB
- WOX1.E/DB

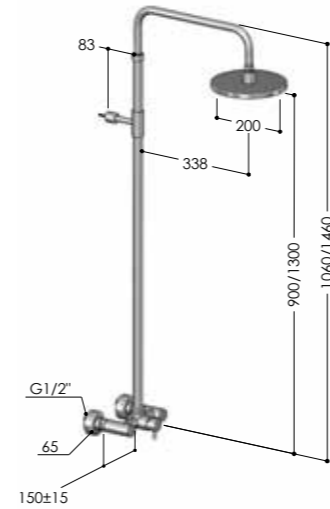

W083



Miscelatore esterno con colonna doccia e soffione 200 mm S06
 Wall-mounted shower mixer, with column and 200 mm showerhead S06
 Mitigeur mural de douche avec colonne et pomme de douche S06
 Monomando mural para ducha con columna y rociador S06
 AP-Brausemischer mit Stange und S06 Kopfbrause

W083/MX

- W083/BX
- W083/MB
- W083/RL
- W083/BB
- W083/BC
- W083/AB
- W083/DB

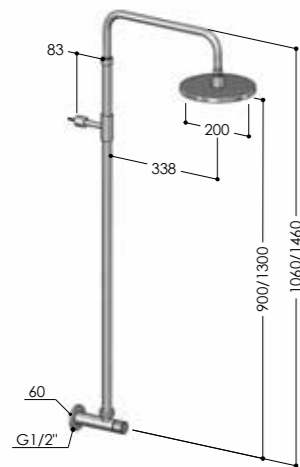

W012



Rubinetto esterno con colonna doccia e soffione 200 mm S06
 Wall-mounted tap with column and 200 mm showerhead S06
 Robinet mural avec colonne et pomme de douche 200 mm S06
 Grifo mural con columna y rociador 200 mm S06
 AP-Ventil mit Stange und 200 mm Kopfbrause S06

W012/MX

- W012/BX
- W012/MB
- W012/RL
- W012/BB
- W012/BC
- W012/AB
- W012/DB

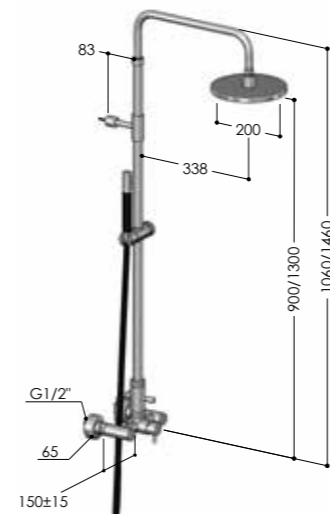

W083.E



Miscelatore esterno con colonna doccia, soffione 200 mm S06 e doccia
 Wall-mounted shower mixer, with column, 200 mm showerhead S06 and handshower
 Mitigeur mural de douche avec colonne, pomme de douche S06 et douchette
 Monomando mural para ducha con columna, rociador S06 y teleducha
 AP-Brausemischer mit Stange, S06 Kopfbrause und Handbrause

W083.E/MX

- W083.E/BX
- W083.E/MB
- W083.E/RL
- W083.E/BB
- W083.E/BC
- W083.E/AB
- W083.E/DB

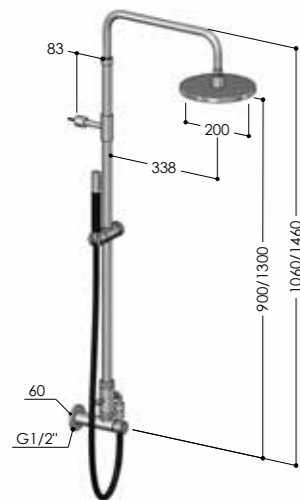

W012.E



Rubinetto esterno con colonna doccia, soffione 200 mm S06 e doccia
 Wall-mounted tap with column, 200 mm showerhead S06 and handshower
 Robinet mural avec colonne, pomme de douche 200 mm S06 et douchette
 Grifo mural con columna, rociador 200 mm S06 y teleducha
 AP-Ventil mit Stange, 200 mm Kopfbrause S06 und Handbrause

W012.E/MX

- W012.E/BX
- W012.E/MB
- W012.E/RL
- W012.E/BB
- W012.E/BC
- W012.E/AB
- W012.E/DB

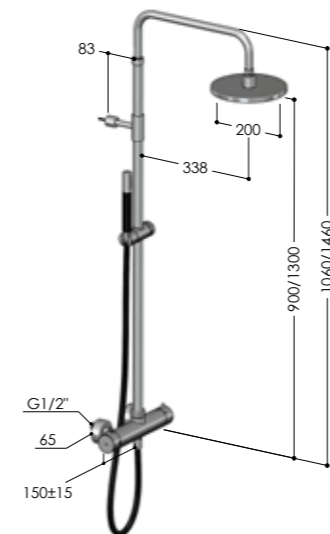

W075.E



Miscelatore termostatico esterno, con colonna doccia, soffione 200 mm S06 e doccia
 Wall-mounted thermostatic mixer, with column, 200 mm showerhead S06 and handshower
 Mitigeur thermostatique de douche avec colonne, pomme de douche S06 et douchette
 Mezclador termostatico para ducha con columna, rociador 200 mm S06 y teleducha
 AP-Thermostat-Brausemischer mit Stange, 200 mm Kopfbrause S06 und Handbrause

W075.E/MX

- W075.E/BX
- W075.E/MB
- W075.E/RL
- W075.E/BB
- W075.E/BC
- W075.E/AB
- W075.E/DB



WX47C.SK.K

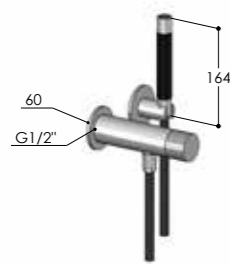

Rubinetto esterno con kit doccia Kneipp
 Wall-mounted tap with Kneipp shower kit
 Robinet mural avec kit de douche Kneipp
 Grifo mural con kit de ducha Kneipp
 AP-Ventil, mit Kneipp Brausekit

- WX47C.SK.K/MX
- WX47C.SK.K/BX
- WX47C.SK.K/MB
- WX47C.SK.K/RL
- WX47C.SK.K/BB
- WX47C.SK.K/BC
- WX47C.SK.K/AB
- WX47C.SK.K/DB

SK

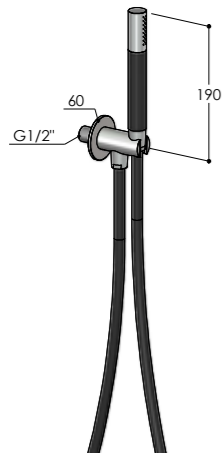

Kit Doccia (Doccetta, flessibile e presa d'acqua)
 Shower kit (handshower, flexible hose and wall coupling)
 Kit de douche (douchette, flexible et coude de sortie)
 Kit de ducha (teleducha, flexible y codo mural)
 Brausekit (Handbrause, Brauseschlauch und Wandanschlußbogen)

- SK/MX
- SK/BX

SK.10

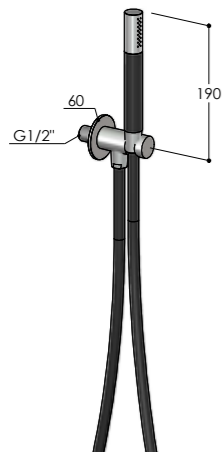

Kit Doccia (Doccetta, flessibile e presa d'acqua)
 Shower kit (handshower, flexible hose and wall coupling)
 Kit de douche (douchette, flexible et coude de sortie)
 Kit de ducha (teleducha, flexible y codo mural)
 Brausekit (Handbrause, Brauseschlauch und Wandanschlußbogen)

- SK.10/MX
- SK.10/BX
- SK.10/MB
- SK.10/RL
- SK.10/BB
- SK.10/BC
- SK.10/AB
- SK.10/DB

SR

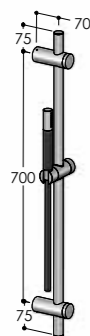

Asta saliscendi, con doccia e flessibile
 Sliding rail with handshower and flexible hose
 Barre coulissante avec douchette et flexible
 Barra deslizante con teleducha y flexible
 Brausestange mit Handbrause und Brauseschlauch

- SR/MX
- SR/BX
- SR/MB
- SR/RL



SB

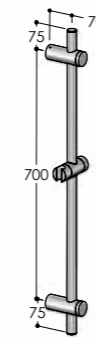

Asta saliscendi (solo asta)
 Sliding rail (bar only)
 Barre coulissante (barre seule)
 Barra deslizante (solo barra)
 Brausestange (nur Stange)

- SB/MX
- SB/BX
- SB/MB
- SB/RL

SR.SLIM

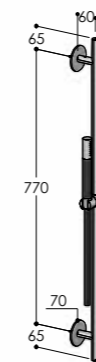

Asta saliscendi, con doccia e flessibile
 Sliding rail with handshower and flexible hose
 Barre coulissante avec douchette et flexible
 Barra deslizante con teleducha y flexible
 Brausestange mit Handbrause und Brauseschlauch

- SR.SLIM/MX
- SR.SLIM/BX
- SR.SLIM/MB
- SR.SLIM/RL
- SR.SLIM/BB
- SR.SLIM/BC
- SR.SLIM/AB
- SR.SLIM/DB

SB.SLIM

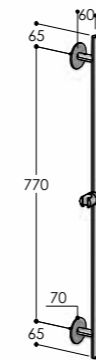

Asta saliscendi (solo asta)
 Sliding rail (bar only)
 Barre coulissante (barre seule)
 Barra deslizante (solo barra)
 Brausestange (nur Stange)

- SB.SLIM/MX
- SB.SLIM/BX
- SB.SLIM/MB
- SB.SLIM/RL
- SB.SLIM/BB
- SB.SLIM/BC
- SB.SLIM/AB
- SB.SLIM/DB

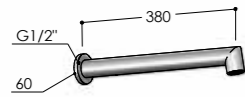

SA35.F

Braccio doccia con soffione integrato
 Shower arm with concealed showerhead
 Bras de douche avec pomme de douche intégrée
 Brazo de ducha con rociador integrado
 Wandbrause mit integrierter Kopfbrause

SA35.F/MX

- SA35.F/BX
- SA35.F/MB
- SA35.F/RL
- SA35.F/BB
- SA35.F/BC
- SA35.F/AB
- SA35.F/DB

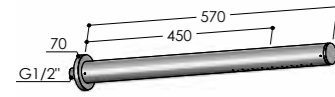

SA40

Braccio doccia con soffione integrato
 Shower arm with concealed showerhead
 Bras de douche avec pomme de douche intégrée
 Brazo de ducha con rociador integrado
 Wandbrause mit integrierter Kopfbrause

SA40/MX

- SA40/BX
- SA40/MB
- SA40/RL
- SA40/BB
- SA40/BC
- SA40/AB
- SA40/DB

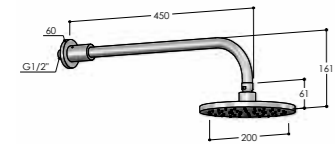

SA21.06

Braccio doccia con soffione S06
 Shower arm with Showerhead S06
 Bras de douche avec pomme de douche S06
 Brazo de ducha con rociador S06
 Wandbrause mit Kopfbrause S06

SA21.06/MX

- SA21.06/BX
- SA21.06/MB
- SA21.06/RL
- SA21.06/BB
- SA21.06/BC
- SA21.06/AB
- SA21.06/DB

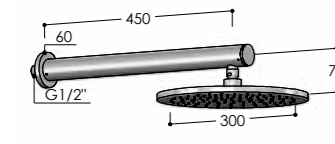

SA33.10

Braccio doccia con soffione S10
 Shower arm with Showerhead S10
 Bras de douche avec pomme de douche S10
 Brazo de ducha con rociador S10
 Wandbrause mit Kopfbrause S10

SA33.10/MX

- SA33.10/BX
- SA33.10/MB
- SA33.10/RL
- SA33.10/BB
- SA33.10/BC
- SA33.10/AB
- SA33.10/DB

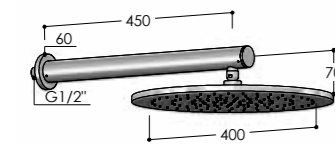

SA40.12

Braccio doccia con soffione S12
 Shower arm with Showerhead S12
 Bras de douche avec pomme de douche S12
 Brazo de ducha con rociador S12
 Wandbrause mit Kopfbrause S12

SA40.12/MX

- SA40.12/BX
- SA40.12/MB
- SA40.12/RL
- SA40.12/BB
- SA40.12/BC
- SA40.12/AB
- SA40.12/DB

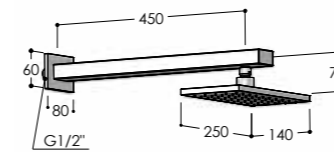

SA53.09

Braccio doccia con soffione S09
 Shower arm with showerhead S09
 Bras de douche avec pomme de douche S09
 Brazo de ducha con rociador S09
 Wandbrause mit Kopfbrause S09

SA53.09/MX

- SA53.09/BX
- SA53.09/MB
- SA53.09/RL

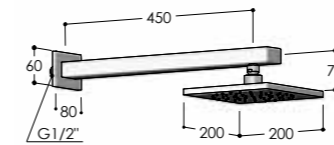

SA53.07

Braccio doccia con soffione S07
 Shower arm with showerhead S07
 Bras de douche avec pomme de douche S07
 Brazo de ducha con rociador S07
 Wandbrause mit Kopfbrause S07

SA53.07/MX

- SA53.07/BX
- SA53.07/MB
- SA53.07/RL
- SA53.07/BB
- SA53.07/BC
- SA53.07/AB
- SA53.07/DB

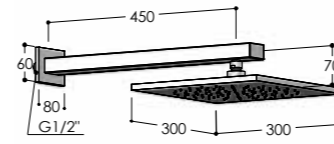

SA53.11

Braccio doccia con soffione S11
 Shower arm with showerhead S11
 Bras de douche avec pomme de douche S11
 Brazo de ducha con rociador S11
 Wandbrause mit Kopfbrause S11

SA53.11/MX

- SA53.11/BX
- SA53.11/MB
- SA53.11/RL
- SA53.11/BB
- SA53.11/BC
- SA53.11/AB
- SA53.11/DB

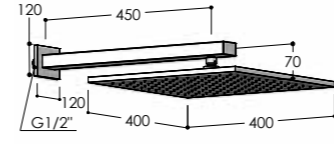

SA53.15

Braccio doccia con soffione S15
 Shower arm with showerhead S15
 Bras de douche avec pomme de douche S15
 Brazo de ducha con rociador S15
 Wandbrause mit Kopfbrause S15

SA53.15/MX

- SA53.15/BX
- SA53.15/MB
- SA53.15/RL
- SA53.15/BB
- SA53.15/BC
- SA53.15/AB
- SA53.15/DB

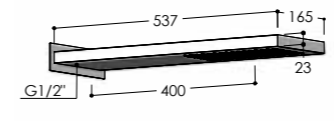

SA150.S

Braccio doccia con soffione integrato
 Shower arm with concealed showerhead
 Bras de douche avec pomme de douche intégrée
 Brazo de ducha con rociador integrado
 Wandbrause mit integrierter Kopfbrause

SA150.S/MX

- SA150.S/BX
- SA150.S/MB
- SA150.S/RL
- SA150.S/BB
- SA150.S/BC
- SA150.S/AB
- SA150.S/DB

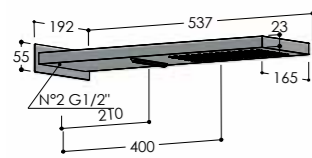

SA150.SC



Braccio doccia con getto a cascata e soffione integrato
 Shower arm with cascade shower and concealed showerhead
 Bras de douche avec jet cascade et pomme de douche intégrée
 Brazo de ducha con ducha de cascada y rociador integrado
 Wandbrausemit mit integrierter Kopfbrause und Wasserfall

SA150.SC/MX

- SA150.SC/BX
- SA150.SC/MB
- SA150.SC/RL
- SA150.SC/BB
- SA150.SC/BC
- SA150.SC/AB
- SA150.SC/DB

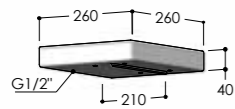

SA300.C

Braccio doccia con getto a cascata
 Shower arm with cascade shower
 Bras de douche avec jet cascade
 Brazo de ducha con ducha de cascada
 Wandbrause mit Wasserfall

SA300.C/MX

- SA300.C/BX
- SA300.C/MB
- SA300.C/RL

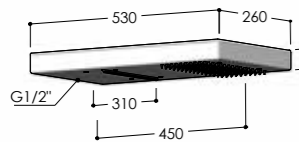

SA300.SC



Braccio doccia con getto a cascata e soffione integrato
 Shower arm with cascade shower and concealed showerhead
 Bras de douche avec jet cascade et pomme de douche intégrée
 Brazo de ducha con ducha de cascada y rociador integrado
 Wandbrause mit integrierter Kopfbrause und Wasserfall

SA300.SC/MX

- SA300.SC/BX
- SA300.SC/MB
- SA300.SC/RL

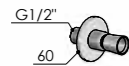

B.J.02

Body-Jet esterno Spray
 Wall-mounted Body-Jet Spray
 Body-Jet mural Spray
 Ducha lateral mural Spray
 AP-Seitenbrause Spray

B.J.02/MX

- B.J.02/BX
- B.J.02/MB
- B.J.02/RL
- B.J.02/BB
- B.J.02/BC
- B.J.02/AB
- B.J.02/DB

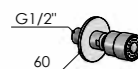

B.J.04

Body-Jet esterno Rain
 Wall-mounted Body-Jet Rain
 Body-Jet mural Rain
 Ducha lateral mural Rain
 AP-Seitenbrause Rain

B.J.04/MX

- B.J.04/BX
- B.J.04/MB
- B.J.04/RL
- B.J.04/BB
- B.J.04/BC
- B.J.04/AB
- B.J.04/DB

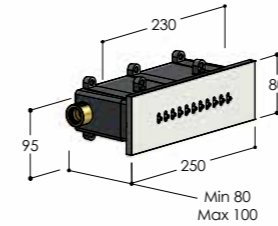

WF.01

Doccia a cascata da incasso Pulse
 Concealed cascade shower Pulse
 Douche cascade à encastrer Pulse
 Ducha de cascada empotrable Pulse
 UP-Wasserfall Pulse

WF.01/MX

- WF.01/BX
- WF.01/MB
- WF.01/RL
- WF.01/BB
- WF.01/BC
- WF.01/AB
- WF.01/DB

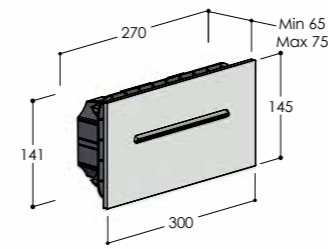

WF.02

Doccia a cascata da incasso Rain
 Concealed cascade shower Rain
 Douche cascade à encastrer Rain
 Ducha de cascada empotrable Rain
 UP-Wasserfall Rain

WF.02/MX

- WF.02/BX
- WF.02/MB
- WF.02/RL
- WF.02/BB
- WF.02/BC
- WF.02/AB
- WF.02/DB

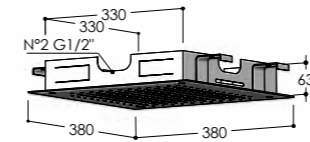

Q380

Doccia a soffitto
 Overhead shower
 Douche de tête
 Rociador de techo empotrable
 Deckeneinbau Kopfbrause

Q380/MX

- Q380/BX
- Q380/MB
- Q380/RL
- Q380/BB
- Q380/BC
- Q380/AB
- Q380/DB

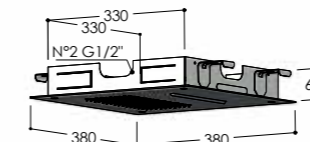

Q380.DF



Doccia a soffitto con getto a cascata e soffione integrato
 Overhead shower with cascade shower and concealed showerhead
 Douche de tête avec jet cascade et pomme de douche intégrée
 Rociador de techo empotrable con ducha de cascada y rociador integrado
 Deckeneinbau Kopfbrause mit Wasserfall und integrierter Kopfbrause

Q380.DF/MX

- Q380.DF/BX
- Q380.DF/MB
- Q380.DF/RL
- Q380.DF/BB
- Q380.DF/BC
- Q380.DF/AB
- Q380.DF/DB

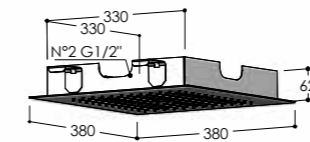

Q380.C



Doccia a soffitto con cascata centrale e soffione integrato
 Overhead shower with central waterfall and concealed showerhead
 Douche de tête avec cascade centrale et pomme de douche intégrée
 Rociador de techo con cascada central y rociador integrado
 Deckeneinbau Kopfbrause mit zentralem Wasserfall und integrierter Kopfbrause

Q380.C/MX

- Q380.C/BX
- Q380.C/MB
- Q380.C/RL
- Q380.C/BB
- Q380.C/BC
- Q380.C/AB
- Q380.C/DB

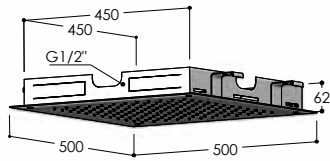

Q500

Doccia a soffitto
 Overhead shower
 Douche de tête
 Rociador de techo empotrable
 Deckeneinbau Kopfbrause

Q500/MX

Q500/BX
 Q500/MB
 Q500/RL
 Q500/BB
 Q500/BC
 Q500/AB
 Q500/DB

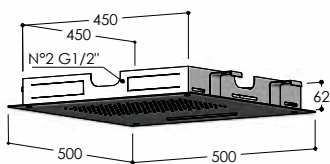

Q500.DF



Doccia a soffitto con getto a cascata e soffione integrato
 Overhead shower with cascade shower and concealed showerhead
 Douche de tête avec jet cascade et pomme de douche intégrée
 Rociador de techo empotrable con ducha de cascada y rociador integrado
 Deckeneinbau Kopfbrause mit Wasserfall und integrierter Kopfbrause

Q500.DF/MX

Q500.DF/BX
 Q500.DF/MB
 Q500.DF/RL
 Q500.DF/BB
 Q500.DF/BC
 Q500.DF/AB
 Q500.DF/DB

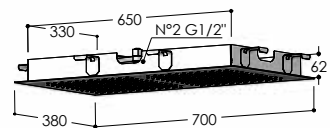

R700

Doccia a soffitto
 Overhead shower
 Douche de tête
 Rociador de techo empotrable
 Deckeneinbau Kopfbrause

R700/MX

R700/BX
 R700/MB
 R700/RL
 R700/BB
 R700/BC
 R700/AB
 R700/DB

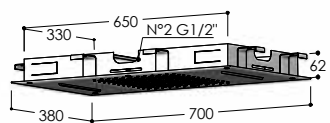

R700.DF



Doccia a soffitto con getto a cascata e soffione integrato
 Overhead shower with cascade shower and concealed showerhead
 Douche de tête avec jet cascade et pomme de douche intégrée
 Rociador de techo empotrable con ducha de cascada y rociador integrado
 Deckeneinbau Kopfbrause mit Wasserfall und integrierter Kopfbrause

R700.DF/MX

R700.DF/BX
 R700.DF/MB
 R700.DF/RL
 R700.DF/BB
 R700.DF/BC
 R700.DF/AB
 R700.DF/DB



YACHT

Deck fixation *pag 190*

Shower *pag 191*



YACHT

YCWS

Pozzetto con alimentazione
Deck-fixation with water supply
Fixation sur pont avec alimentation
Fijación sobre cubierta con suministro de agua
Deckbefestigung mit Wasserversorgung

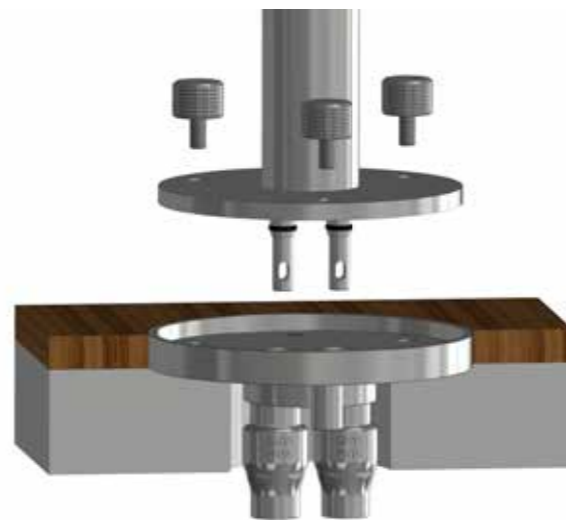

YEWS

Kit di fissaggio su ponte per alimentazione esterna
Deck-fixation for external water supply
Fixation sur pont pour alimentation en eau extérieure
Fijación sobre cubierta para suministro de agua externo
Deckbefestigung mit Wasserversorgung

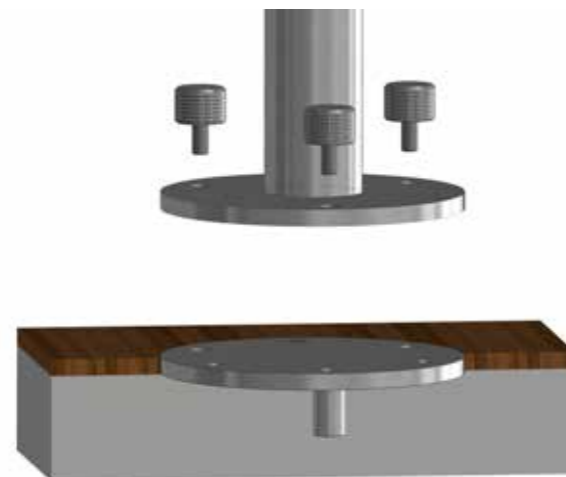
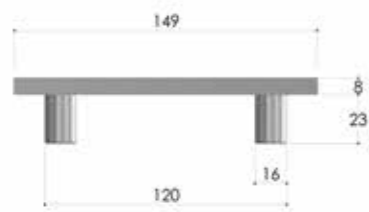

C50AS.YCWS.M

Colonna doccia con miscelatore e soffione S06
Shower column with mixer and showerhead S06
Colonne douche avec mitigeur et pomme de douche S06
Column de ducha con monomando y rociador S06
Duschsäule mit Einhebelmischer und Kopfbrause S06

Corpo incasso_Concealed body_Corps encastré_Cuerpo empotrado_UP-Teil (pag. 190)

YCWS

Parti esterne_External parts_Parties externes_Parties externas_AP-Teile

C50AS.XYCWS.M/MX

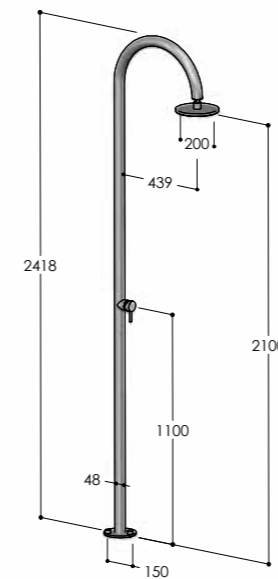

C50AS.YCWS.M

Colonna doccia con miscelatore e soffione S06
Shower column with mixer and showerhead S06
Colonne douche avec mitigeur et pomme de douche S06
Column de ducha con monomando y rociador S06
Duschsäule mit Einhebelmischer und Kopfbrause S06

Corpo incasso_Concealed body_Corps encastré_Cuerpo empotrado_UP-Teil (pag. 190)

YEWS

Parti esterne_External parts_Parties externes_Parties externas_AP-Teile

C50AS.XYEWS.M/MX

C50AS.YCWS.M.D

Colonna doccia divisibile con miscelatore e soffione S06
Divible shower column with mixer and showerhead S06
Colonne douche divisible avec mitigeur et pomme de douche S06
Column de ducha divisible con monomando y rociador S06
Trennbare Duschsäule mit Einhebelmischer und Kopfbrause S06

Corpo incasso_Concealed body_Corps encastré_Cuerpo empotrado_UP-Teil (pag. 190)

YCWS

Parti esterne_External parts_Parties externes_Parties externas_AP-Teile

C50AS.XYCWS.M.D/MX

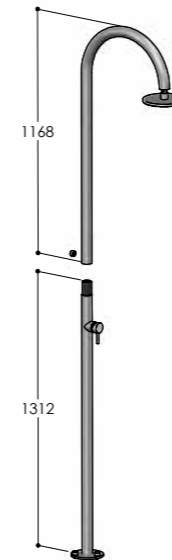

C50AS.YEWS.M.D

Colonna doccia divisibile con miscelatore e soffione S06
Divible shower column with mixer and showerhead S06
Colonne douche divisible avec mitigeur et pomme de douche S06
Column de ducha divisible con monomando y rociador S06
Trennbare Duschsäule mit Einhebelmischer und Kopfbrause S06

Corpo incasso_Concealed body_Corps encastré_Cuerpo empotrado_UP-Teil (pag. 190)

YEWS

Parti esterne_External parts_Parties externes_Parties externas_AP-Teile

C50AS.XYEWS.M.D/MX

C50AS.YCWS.ME

Colonna doccia con miscelatore, soffione S06 e doccia
Shower column with mixer, showerhead S06 and handshower
Colonne douche avec mitigeur, pomme de douche S06 et douchette
Column de ducha con monomando, rociador S06 y teleducha
Duschsäule mit Einhebelmischer, Kopfbrause S06 und Handbrause

Corpo incasso_Concealed body_Corps encastré_Cuerpo empotrado_UP-Teil (pag. 190)

YCWS

Parti esterne_External parts_Parties externes_Parties externas_AP-Teile

C50AS.XYCWS.ME/MX

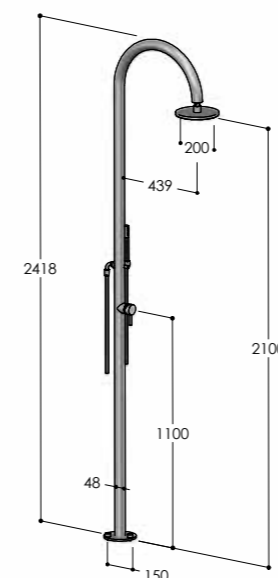

C50AS.YCWS.ME

Colonna doccia con miscelatore, soffione S06 e doccia
Shower column with mixer, showerhead S06 and handshower
Colonne douche avec mitigeur, pomme de douche S06 et douchette
Column de ducha con monomando, rociador S06 y teleducha
Duschsäule mit Einhebelmischer, Kopfbrause S06 und Handbrause

Corpo incasso_Concealed body_Corps encastré_Cuerpo empotrado_UP-Teil (pag. 190)

YEWS

Parti esterne_External parts_Parties externes_Parties externas_AP-Teile

C50AS.XYEWS.ME/MX

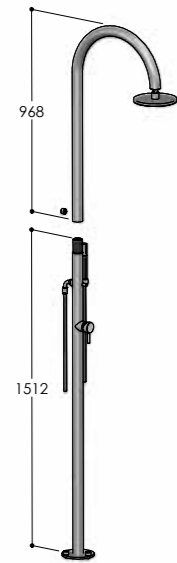

C50AS.YCWS.ME.D

Colonna doccia divisibile con miscelatore, soffione S06 e doccetta
 Divisible shower column with mixer, showerhead S06 and handshower
 Colonne douche divisible avec mitigeur, pomme de douche S06 et douchette
 Columna de ducha divisible con monomando, rociador S06 y teleducha
 Trennbare Duschsäule mit Einhebelmischer, Kopfbrause S06 und Handbrause

Corpo incasso_Concealed body_Corps encastré_Cuerpo empotrado_UP-Teil (pag. 190)

YCWS

Parti esterne_External parts_Parties externes_Parties externas_AP-Teile

C50AS.XYCWS.ME.D/MX

C50AS.YEWS.ME.D

Colonna doccia divisibile con miscelatore, soffione S06 e doccetta
 Divisible shower column with mixer, showerhead S06 and handshower
 Colonne douche divisible avec mitigeur, pomme de douche S06 et douchette
 Columna de ducha divisible con monomando, rociador S06 y teleducha
 Trennbare Duschsäule mit Einhebelmischer, Kopfbrause S06 und Handbrause

Corpo incasso_Concealed body_Corps encastré_Cuerpo empotrado_UP-Teil (pag. 190)

YEWS

Parti esterne_External parts_Parties externes_Parties externas_AP-Teile

C50AS.XYEWS.ME.D/MX

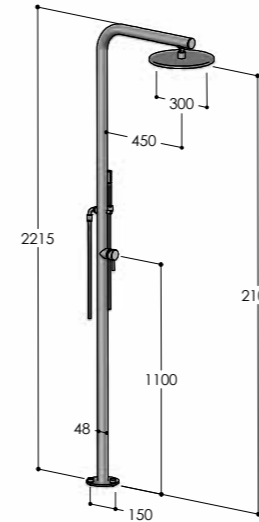

C40.YCWS.ME

Colonna doccia con miscelatore, soffione S10 e doccetta
 Shower column with mixer, showerhead S10 and handshower
 Colonne douche avec mitigeur, pomme de douche S10 et douchette
 Columna de ducha con monomando, rociador S10 y teleducha
 Duschsäule mit Einhebelmischer, Kopfbrause S10 und Handbrause

Corpo incasso_Concealed body_Corps encastré_Cuerpo empotrado_UP-Teil (pag. 190)

YCWS

Parti esterne_External parts_Parties externes_Parties externas_AP-Teile

C40.XYCWS.ME/MX

C40.YEWS.ME

Colonna doccia con miscelatore, soffione S10 e doccetta
 Shower column with mixer, showerhead S10 and handshower
 Colonne douche avec mitigeur, pomme de douche S10 et douchette
 Columna de ducha con monomando, rociador S10 y teleducha
 Duschsäule mit Einhebelmischer, Kopfbrause S10 und Handbrause

Corpo incasso_Concealed body_Corps encastré_Cuerpo empotrado_UP-Teil (pag. 190)

YEWS

Parti esterne_External parts_Parties externes_Parties externas_AP-Teile

C40.XYEWS.ME/MX

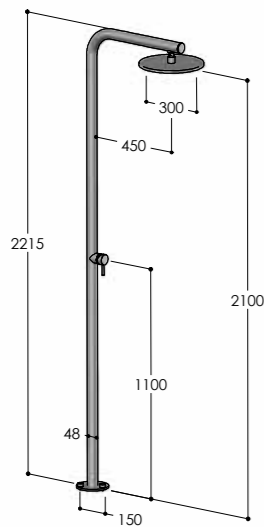

C40.YCWS.M

Colonna doccia con miscelatore e soffione S10
 Shower column with mixer and showerhead S10
 Colonne douche avec mitigeur et pomme de douche S10
 Columna de ducha con monomando y rociador S10
 Duschsäule mit Einhebelmischer und Kopfbrause S10

Corpo incasso_Concealed body_Corps encastré_Cuerpo empotrado_UP-Teil (pag. 190)

YCWS

Parti esterne_External parts_Parties externes_Parties externas_AP-Teile

C40.XYCWS.M/MX

C40.YEWS.M

Colonna doccia con miscelatore e soffione S10
 Shower column with mixer and showerhead S10
 Colonne douche avec mitigeur et pomme de douche S10
 Columna de ducha con monomando y rociador S10
 Duschsäule mit Einhebelmischer und Kopfbrause S10

Corpo incasso_Concealed body_Corps encastré_Cuerpo empotrado_UP-Teil (pag. 190)

YEWS

Parti esterne_External parts_Parties externes_Parties externas_AP-Teile

C40.XYEWS.M/MX

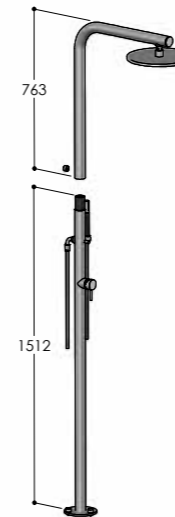

C40.YCWS.ME.D

Colonna doccia divisibile con miscelatore, soffione S10 e doccetta
 Divisible shower column with mixer, showerhead S10 and handshower
 Colonne douche divisible avec mitigeur, pomme de douche S10 et douchette
 Columna de ducha divisible con monomando, rociador S10 y teleducha
 Trennbare Duschsäule mit Einhebelmischer, Kopfbrause S10 und Handbrause

Corpo incasso_Concealed body_Corps encastré_Cuerpo empotrado_UP-Teil (pag. 190)

YCWS

Parti esterne_External parts_Parties externes_Parties externas_AP-Teile

C40.XYCWS.ME.D/MX

C40.YEWS.ME.D

Colonna doccia divisibile con miscelatore, soffione S10 e doccetta
 Divisible shower column with mixer, showerhead S10 and handshower
 Colonne douche divisible avec mitigeur, pomme de douche S10 et douchette
 Columna de ducha divisible con monomando, rociador S10 y teleducha
 Trennbare Duschsäule mit Einhebelmischer, Kopfbrause S10 und Handbrause

Corpo incasso_Concealed body_Corps encastré_Cuerpo empotrado_UP-Teil (pag. 190)

YEWS

Parti esterne_External parts_Parties externes_Parties externas_AP-Teile

C40.XYEWS.ME.D/MX

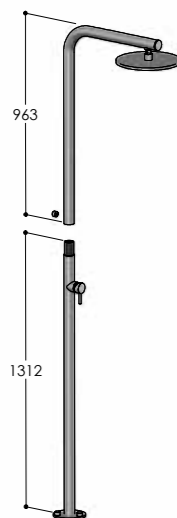

C40.YCWS.M.D

Colonna doccia divisibile con miscelatore e soffione S10
 Divible shower column with mixer and showerhead S10
 Colonne douche divisible avec mitigeur et pomme de douche S10
 Columna de ducha divisible con monomando y rociador S10
 Trennbare Duschsäule mit Einhebelmischer und Kopfbrause S10

Corpo incasso_Concealed body_Corps encastré_Cuerpo empotrado_UP-Teil (pag. 190)

YCWS

Parti esterne_External parts_Parties externes_Parties externas_AP-Teile

C40.XYCWS.M.D/MX

C40.YEWS.M.D

Colonna doccia divisibile con miscelatore e soffione S10
 Divible shower column with mixer and showerhead S10
 Colonne douche divisible avec mitigeur et pomme de douche S10
 Columna de ducha divisible con monomando y rociador S10
 Trennbare Duschsäule mit Einhebelmischer und Kopfbrause S10

Corpo incasso_Concealed body_Corps encastré_Cuerpo empotrado_UP-Teil (pag. 190)

YEWS

Parti esterne_External parts_Parties externes_Parties externas_AP-Teile

C40.XYEWS.M.D/MX

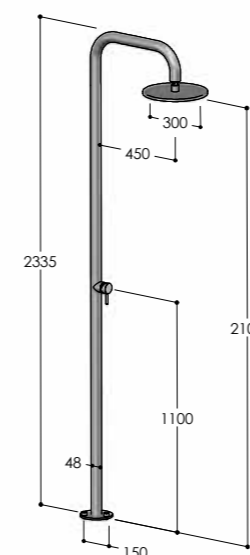

BW50.YCWS.M

Colonna doccia con miscelatore e soffione S10
 Shower column with mixer and showerhead S10
 Colonne douche avec mitigeur et pomme de douche S10
 Columna de ducha con monomando y rociador S10
 Duschsäule mit Einhebelmischer und Kopfbrause S10

Corpo incasso_Concealed body_Corps encastré_Cuerpo empotrado_UP-Teil (pag. 190)

YCWS

Parti esterne_External parts_Parties externes_Parties externas_AP-Teile

BW50.XYCWS.M/MX

BW50.YEWS.M

Colonna doccia con miscelatore e soffione S10
 Shower column with mixer and showerhead S10
 Colonne douche avec mitigeur et pomme de douche S10
 Columna de ducha con monomando y rociador S10
 Duschsäule mit Einhebelmischer und Kopfbrause S10

Corpo incasso_Concealed body_Corps encastré_Cuerpo empotrado_UP-Teil (pag. 190)

YEWS

Parti esterne_External parts_Parties externes_Parties externas_AP-Teile

BW50.XYEWS.M/MX

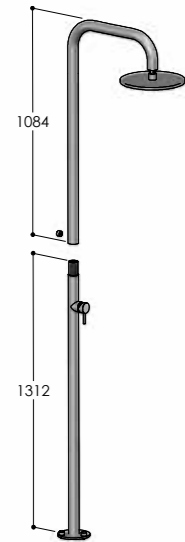

BW50.YCWS.M.D

Colonna doccia divisibile con miscelatore e soffione S10
 Divible shower column with mixer and showerhead S10
 Colonne douche divisible avec mitigeur et pomme de douche S10
 Columna de ducha divisible con monomando y rociador S10
 Trennbare Duschsäule mit Einhebelmischer und Kopfbrause S10

Corpo incasso_Concealed body_Corps encastré_Cuerpo empotrado_UP-Teil (pag. 190)

YCWS

Parti esterne_External parts_Parties externes_Parties externas_AP-Teile

BW50.XYCWS.M.D/MX

BW50.YEWS.M.D

Colonna doccia divisibile con miscelatore e soffione S10
 Divible shower column with mixer and showerhead S10
 Colonne douche divisible avec mitigeur et pomme de douche S10
 Columna de ducha divisible con monomando y rociador S10
 Trennbare Duschsäule mit Einhebelmischer und Kopfbrause S10

Corpo incasso_Concealed body_Corps encastré_Cuerpo empotrado_UP-Teil (pag. 190)

YEWS

Parti esterne_External parts_Parties externes_Parties externas_AP-Teile

BW50.XYEWS.M.D/MX

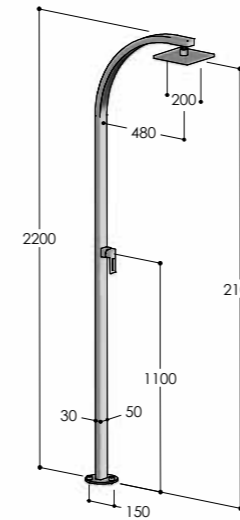

Q53.YCWS.M

Colonna doccia con miscelatore e soffione S07
 Shower column with mixer and showerhead S07
 Colonne douche avec mitigeur et pomme de douche S07
 Columna de ducha con monomando y rociador S07
 Duschsäule mit Einhebelmischer und Kopfbrause S07

Corpo incasso_Concealed body_Corps encastré_Cuerpo empotrado_UP-Teil (pag. 190)

YCWS

Parti esterne_External parts_Parties externes_Parties externas_AP-Teile

Q53.XYCWS.M/MX

Q53.YEWS.M

Colonna doccia con miscelatore e soffione S07
 Shower column with mixer and showerhead S07
 Colonne douche avec mitigeur et pomme de douche S07
 Columna de ducha con monomando y rociador S07
 Duschsäule mit Einhebelmischer und Kopfbrause S07

Corpo incasso_Concealed body_Corps encastré_Cuerpo empotrado_UP-Teil (pag. 190)

YEWS

Parti esterne_External parts_Parties externes_Parties externas_AP-Teile

Q53.XYEWS.M/MX

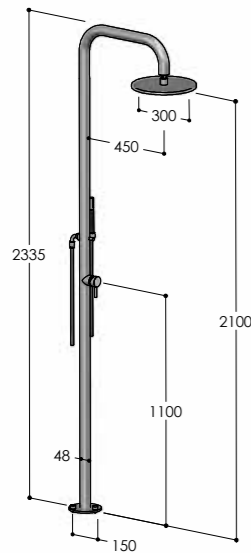

BW50.YCWS.ME

Colonna doccia con miscelatore, soffione S10 e doccia
 Shower column with mixer, showerhead S10 and handshower
 Colonne douche avec mitigeur, pomme de douche S10 et douchette
 Columna de ducha con monomando, rociador S10 y teleducha
 Duschsäule mit Einhebelmischer, Kopfbrause S10 und Handbrause

Corpo incasso_Concealed body_Corps encastré_Cuerpo empotrado_UP-Teil (pag. 190)

YCWS

Parti esterne_External parts_Parties externes_Parties externas_AP-Teile

BW50.XYCWS.ME/MX

BW50.YEWS.ME

Colonna doccia con miscelatore, soffione S10 e doccia
 Shower column with mixer, showerhead S10 and handshower
 Colonne douche avec mitigeur, pomme de douche S10 et douchette
 Columna de ducha con monomando, rociador S10 y teleducha
 Duschsäule mit Einhebelmischer, Kopfbrause S10 und Handbrause

Corpo incasso_Concealed body_Corps encastré_Cuerpo empotrado_UP-Teil (pag. 190)

YEWS

Parti esterne_External parts_Parties externes_Parties externas_AP-Teile

BW50.XYEWS.ME/MX

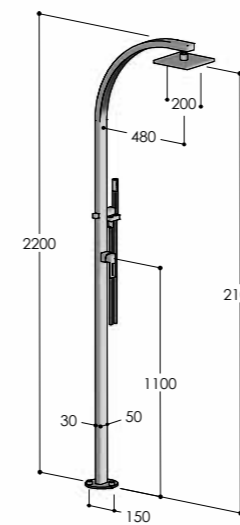

Q53.YCWS.ME

Colonna doccia con miscelatore, soffione S07 e doccia
 Shower column with mixer, showerhead S07 and handshower
 Colonne douche avec mitigeur, pomme de douche S07 et douchette
 Columna de ducha con monomando, rociador S07 y teleducha
 Duschsäule mit Einhebelmischer, Kopfbrause S07 und Handbrause

Corpo incasso_Concealed body_Corps encastré_Cuerpo empotrado_UP-Teil (pag. 190)

YCWS

Parti esterne_External parts_Parties externes_Parties externas_AP-Teile

Q53.XYCWS.ME/MX

Q53.YEWS.ME

Colonna doccia con miscelatore, soffione S07 e doccia
 Shower column with mixer, showerhead S07 and handshower
 Colonne douche avec mitigeur, pomme de douche S07 et douchette
 Columna de ducha con monomando, rociador S07 y teleducha
 Duschsäule mit Einhebelmischer, Kopfbrause S07 und Handbrause

Corpo incasso_Concealed body_Corps encastré_Cuerpo empotrado_UP-Teil (pag. 190)

YEWS

Parti esterne_External parts_Parties externes_Parties externas_AP-Teile

Q53.XYEWS.ME/MX

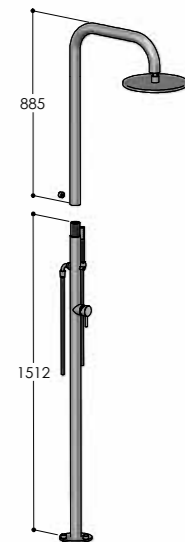

BW50.YCWS.ME.D

Colonna doccia divisibile con miscelatore, soffione S10 e doccia
 Divisible shower column with mixer, showerhead S10 and handshower
 Colonne douche divisible avec mitigeur, pomme de douche S10 et douchette
 Columna de ducha divisible con monomando, rociador S10 y teleducha
 Trennbare Duschsäule mit Einhebelmischer, Kopfbrause S10 und Handbrause

Corpo incasso_Concealed body_Corps encastré_Cuerpo empotrado_UP-Teil (pag. 190)

YCWS

Parti esterne_External parts_Parties externes_Parties externas_AP-Teile

BW50.XYCWS.ME.D/MX

BW50.YEWS.ME.D

Colonna doccia divisibile con miscelatore, soffione S10 e doccia
 Divisible shower column with mixer, showerhead S10 and handshower
 Colonne douche divisible avec mitigeur, pomme de douche S10 et douchette
 Columna de ducha divisible con monomando, rociador S10 y teleducha
 Trennbare Duschsäule mit Einhebelmischer, Kopfbrause S10 und Handbrause

Corpo incasso_Concealed body_Corps encastré_Cuerpo empotrado_UP-Teil (pag. 190)

YEWS

Parti esterne_External parts_Parties externes_Parties externas_AP-Teile

BW50.XYEWS.ME.D/MX

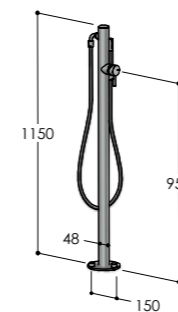

COL50.YCWS.M

Colonna con miscelatore e doccia
 Column with mixer and handshower
 Colonne avec mitigeur et douchette
 Columna con monomando y teleducha
 Säule mit Einhebelmischer und Handbrause

Corpo incasso_Concealed body_Corps encastré_Cuerpo empotrado_UP-Teil (pag. 190)

YCWS

Parti esterne_External parts_Parties externes_Parties externas_AP-Teile

COL50.XYCWS.M/MX

COL50.YEWS.M

Colonna con miscelatore e doccia
 Column with mixer and handshower
 Colonne avec mitigeur et douchette
 Columna con monomando y teleducha
 Säule mit Einhebelmischer und Handbrause

Corpo incasso_Concealed body_Corps encastré_Cuerpo empotrado_UP-Teil (pag. 190)

YEWS

Parti esterne_External parts_Parties externes_Parties externas_AP-Teile

COL50.XYEWS.M/MX



ACCESSORIES



Accessories

pag 198

Accessories for
shower columns

pag 206

ACCESSORIES



PS03

Presa d'acqua
Wall coupling
Coude de sortie
Codo mural
Wandanschlußbogen

PS03/MX

PS03/BX
PS03/MB
PS03/RL
PS03/BB
PS03/BC
PS03/AB
PS03/DB



PS04

Supporto a muro per doccia
Wall-mounted handshower bracket
Support mural pour douche
Soporte mural para teleducha
Wandhalter für Handbrause

PS04/MX

PS04/BX



PS05

Presa d'acqua con supporto per doccia
Wall coupling with handshower bracket
Coude de sortie avec support pour douche
Codo mural con soporte para teleducha
Wandanschlußbogen, mit Handbrausehalter

PS05/MX

PS05/BX



PS09

Supporto a muro per doccia
Wall-mounted handshower bracket
Support mural pour douche
Soporte mural para teleducha
Wandhalter für Handbrause

PS09/MX

PS09/BX
PS09/MB
PS09/RL
PS09/BB
PS09/BC
PS09/AB
PS09/DB



PS10

Presa d'acqua con supporto per doccia
Wall coupling with handshower bracket
Coude de sortie avec support pour douche
Codo mural con soporte para teleducha
Wandanschlußbogen, mit Handbrausehalter

PS10/MX

PS10/BX
PS10/MB
PS10/RL
PS10/BB
PS10/BC
PS10/AB
PS10/DB



D10

Doccetta tonda, acciaio inox Aisi 316 con impugnatura in resina nera
Round handshower, inox steel Aisi 316 with handle in black resin
Douchette ronde, acier inox 316 avec poignée en résine noire
Teleducha redonda, acero inox 316 con mango in resina negra
Runde Handbrause, Edelstahl Aisi 316 mit schwarzem Resin Griff

D10/MX

D10/BX
D10/MB
D10/RL
D10/BB
D10/BC
D10/AB
D10/DB



D06

Doccetta tonda, acciaio inox Aisi 316
Round antiscaling handshower, inox steel Aisi 316
Douchette ronde anticalcaire, acier Aisi 316
Teleducha redonda anticalcárea, acero inox 316
Selbstreinigende runde Handbrause, Edelstahl Aisi 316

D06/MX

D06/BX
D06/MB
D06/RL
D06/BB
D06/BC
D06/AB
D06/DB



D04

Doccetta, ottone lucido naturale
Handshower, polished brass
Douchette, laiton poli
Teleducha, latón pulido
Handbrause, Messing poliert

D04



D03.Q

Doccetta quadrata anticalcare, ottone cromato
Square antiscaling handshower, chromed brass
Douchette carrée anticalcaire, laiton chromé
Teleducha cuadra anticalcárea, latón cromado
Selbstreinigende viereckige Handbrause, Messing verchromt

D03.Q/MX

D03.Q/BX € 90,00



D12

Doccetta tonda, acciaio inox Aisi 316 con impugnatura in resina nera
Round handshower, inox steel Aisi 316 with handle in black resin
Douchette ronde, acier inox 316 avec poignée en résine noire
Teleducha redonda, acero inox 316 con mango in resina negra
Runde Handbrause, Edelstahl Aisi 316 mit schwarzem Resin Griff

D12/MX

D12/BX
D12/MB
D12/RL
D12/BB
D12/BC
D12/AB
D12/DB



D14.K

Doccetta Kneipp, acciaio inox Aisi 316 con impugnatura in resina nera
 Kneipp handshower, inox steel Aisi 316 with handle in black resin
 Douchette Kneipp, acier inox 316 avec poignée en résine noire
 Teleducha Kneipp, acero inox 316 con mango in resina negra
 Kneipp Handbrause, Edelstahl Aisi 316 mit schwarzem Resin Griff

D14.K/MX

- _____ D14.K/BX
- _____ D14.K/MB
- _____ D14.K/RL
- _____ D14.K/BB
- _____ D14.K/BC
- _____ D14.K/AB
- _____ D14.K/DB

FLX02



Flessibile 150 cm doppia aggraffatura, ottone naturale
 Flexible hose 150 cm, double hemming, polished brass
 Flexible 150 cm, double agraffage, laiton poli
 Flexo 150 cm, doble engatillado, latón pulido
 Brauseschlauch 150 cm, Doppelwicklung, Messing poliert

FLX02

FLX03



Flessibile antitorsione 150 cm in acciaio 316 con rivestimento in PVC trasparente
 Twist-free stainless steel 316 flexible hose 150 cm with transparent PVC cover
 Flexible 150 cm antitorsion en acier 316 avec revêtement PVC transparent
 Flexo antitorsión 150 cm en acero 316, con revestimiento en PVC transparente
 Verdrehsicherer Brauseschlauch 150 cm aus Edelstahl 316, mit transparenter PVC-Hülle

FLX03/MX

- _____ FLX03/BX

FLX04



Flessibile antitorsione 150 cm, PVC nero con calotte in acciaio 316
 Twist-free flexible hose 150 cm, black PVC with tail nuts in 316 steel
 Flexible 150 cm antitorsion, PVC noir avec écrous en acier 316
 Flexo antitorsión 150 cm, PVC color negro con tuercas en acero 316
 Verdrehsicherer Brauseschlauch 150 cm, PVC Schwarz mit Muttern aus Edelstahl 316

FLX04/MX

- _____ FLX04/BX

FLX06



Flessibile antitorsione 150 cm, PET nero con calotte in acciaio 316
 Twist-free flexible hose 150 cm, black PET with tail nuts in 316 steel
 Flexible 150 cm antitorsion, PET noir avec écrous en acier 316
 Flexo antitorsión 150 cm, PET color negro con tuercas en acero 316
 Verdrehsicherer Brauseschlauch 150 cm, PET Schwarz mit Muttern aus Edelstahl 316

FLX06/MX

- _____ FLX06/BX
- _____ FLX06/MB
- _____ FLX06/RL
- _____ FLX06/BB
- _____ FLX06/BC
- _____ FLX06/AB
- _____ FLX06/DB



FLX07

Flessibile antitorsione 150 cm, PET argento con calotte in acciaio 316
 Twist-free flexible hose 150 cm, silver PET with tail nuts in 316 steel
 Flexible 150 cm antitorsion, PET argent avec écrous en acier 316
 Flexo antitorsión 150 cm, PET color plata con tuercas en acero 316
 Verdrehsicherer Brauseschlauch 150 cm, PET Silber mit Muttern aus Edelstahl 316

FLX07/MX

- _____ FLX07/BX
- _____ FLX07/MB
- _____ FLX07/RL
- _____ FLX07/BB
- _____ FLX07/BC
- _____ FLX07/AB
- _____ FLX07/DB



FLX08

Flessibile antitorsione 150 cm, PET nero con calotte in acciaio 316, MF
 Twist-free flexible hose 150 cm, black PET with tail nuts in 316 steel, MF
 Flexible 150 cm antitorsion, PET noir avec écrous en acier 316, MF
 Flexo antitorsión 150 cm, PET color negro con tuercas en acero 316, MF
 Verdrehsicherer Brauseschlauch 150 cm, PET Schwarz mit Muttern aus Edelstahl 316, MF

FLX08/MX

- _____ FLX08/BX
- _____ FLX08/MB
- _____ FLX08/RL
- _____ FLX08/BB
- _____ FLX08/BC
- _____ FLX08/AB
- _____ FLX08/DB



S02.ABS

Soffione anticalcare, ABS cromato
 Antiscald showerhead, chromed ABS
 Pomme de douche anticalcaire, ABS chromé
 Rociador anticalcaréa, ABS cromado
 Selbstreinigende Kopfbrause, ABS verchromt

S02.ABS



S03

Soffione lavapiedi, acciaio inox Aisi 316
 Footwash head, inox steel Aisi 316
 Pomme rince-pieds, acier inox Aisi 316
 Rociador lava pies, acero inox Aisi 316
 Fußbrause, Edelstahl Aisi 316

S03/MX

- _____ S03/BX
- _____ S03/MB
- _____ S03/RL
- _____ S03/BB
- _____ S03/BC
- _____ S03/AB
- _____ S03/DB



S04

Soffione lavapiedi, acciaio inox Aisi 316
 Footwash head, inox steel Aisi 316
 Pomme rince-pieds, acier inox Aisi 316
 Rociador lava pies, acero inox Aisi 316
 Fußbrause, Edelstahl Aisi 316

S04/MX

- _____ S04/BX
- _____ S04/MB
- _____ S04/RL
- _____ S04/BB
- _____ S04/BC
- _____ S04/AB
- _____ S04/DB



S05



Soffione lavapiedi, ottone cromato
Footwash head, chromed brass
Pomme rince-pieds , laiton chromé
Rociador lava pies , latón cromado
Fußbrause, Messing verchromt

S05/MX

- _____ S05/BX
- _____ S05/MB
- _____ S05/RL

S06

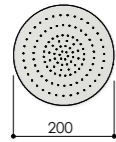

Soffione anticalcare, acciaio inox Aisi 316
Antiscale showerhead, inox steel Aisi 316
Pomme de douche anticalcaire, acier inox Aisi 316
Rociador ducha anticalcárea, acero inox Aisi 316
Selbstreinigende Kopfbrause, Edelstahl Aisi 316

S06/MX

- _____ S06/BX
- _____ S06/MB
- _____ S06/RL
- _____ S06/BB
- _____ S06/BC
- _____ S06/AB
- _____ S06/DB

S07

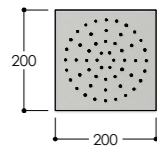

Soffione anticalcare, acciaio inox Aisi 316
Antiscale showerhead, inox steel Aisi 316
Pomme de douche anticalcaire, acier inox Aisi 316
Rociador ducha anticalcárea, acero inox Aisi 316
Selbstreinigende Kopfbrause, Edelstahl Aisi 316

S07/MX

- _____ S07/BX
- _____ S07/MB
- _____ S07/RL
- _____ S07/BB
- _____ S07/BC
- _____ S07/AB
- _____ S07/DB

S08



Soffione anticalcare, ottone lucido naturale
Antiscale showerhead, polished brass
Pomme de douche anticalcaire , laiton poli
Rociador ducha anticalcárea, latón pulido
Selbstreinigende Kopfbrause, Messing poliert

S08

S09

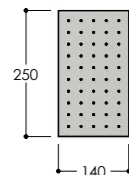

Soffione anticalcare, acciaio inox Aisi 316
Antiscale showerhead, inox steel Aisi 316
Pomme de douche anticalcaire, acier inox Aisi 316
Rociador ducha anticalcárea, acero inox Aisi 316
Selbstreinigende Kopfbrause, Edelstahl Aisi 316

S09/MX

- _____ S09/BX
- _____ S09/MB
- _____ S09/RL



S10

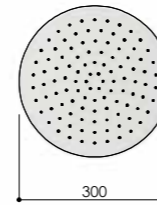

Soffione anticalcare, acciaio inox Aisi 316
Antiscale showerhead, inox steel Aisi 316
Pomme de douche anticalcaire, acier inox Aisi 316
Rociador ducha anticalcárea, acero inox Aisi 316
Selbstreinigende Kopfbrause, Edelstahl Aisi 316

S10/MX

- _____ S10/BX
- _____ S10/MB
- _____ S10/RL
- _____ S10/BB
- _____ S10/BC
- _____ S10/AB
- _____ S10/DB

S11

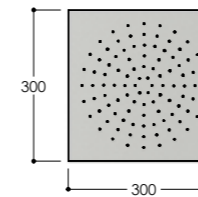

Soffione anticalcare, acciaio inox Aisi 316
Antiscale showerhead, inox steel Aisi 316
Pomme de douche anticalcaire , acier inox Aisi 316
Rociador ducha anticalcárea , acero inox Aisi 316
Selbstreinigende Kopfbrause , Edelstahl Aisi 316

S11/MX

- _____ S11/BX
- _____ S11/MB
- _____ S11/RL
- _____ S11/BB
- _____ S11/BC
- _____ S11/AB
- _____ S11/DB

S12

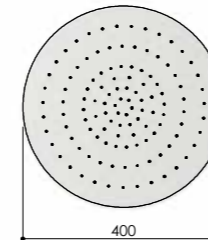

Soffione anticalcare, acciaio inox Aisi 316
Antiscale showerhead, inox steel Aisi 316
Pomme de douche anticalcaire , acier inox Aisi 316
Rociador ducha anticalcárea , acero inox Aisi 316
Selbstreinigende Kopfbrause , Edelstahl Aisi 316

S12/MX

- _____ S12/BX
- _____ S12/MB
- _____ S12/RL
- _____ S12/BB
- _____ S12/BC
- _____ S12/AB
- _____ S12/DB

S15

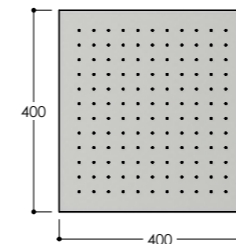

Soffione anticalcare, acciaio inox Aisi 316
Antiscale showerhead, inox steel Aisi 316
Pomme de douche anticalcaire , acier inox Aisi 316
Rociador ducha anticalcárea , acero inox Aisi 316
Selbstreinigende Kopfbrause , Edelstahl Aisi 316

S15/MX

- _____ S15/BX
- _____ S15/MB
- _____ S15/RL
- _____ S15/BB
- _____ S15/BC
- _____ S15/AB
- _____ S15/DB

S16



Soffione anticalcare, ottone lucido naturale
Antiscale showerhead, polished brass
Pomme de douche anticalcaire , laiton poli
Rociador ducha anticalcárea, latón pulido
Selbstreinigende Kopfbrause, Messing poliert

S16

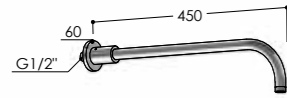

SA.R

Braccio doccia tondo
Round shower arm
Bras de douche rond
Brazo rociador redondo
Brausearm, rund

SA.R/MX

SA.R/BX
SA.R/MB
SA.R/RL
SA.R/BB
SA.R/BC
SA.R/AB
SA.R/DB

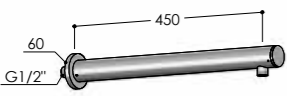

SA.RC

Braccio doccia tondo
Round shower arm
Bras de douche rond
Brazo rociador redondo
Brausearm, rund

SA.RC/MX

SA.RC/BX
SA.RC/MB
SA.RC/RL
SA.RC/BB
SA.RC/BC
SA.RC/AB
SA.RC/DB

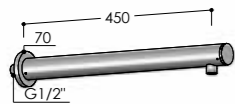

SA.RB

Braccio doccia tondo
Round shower arm
Bras de douche rond
Brazo rociador redondo
Brausearm, rund

SA.RB/MX

SA.RB/BX
SA.RB/MB
SA.RB/RL
SA.RB/BB
SA.RB/BC
SA.RB/AB
SA.RB/DB

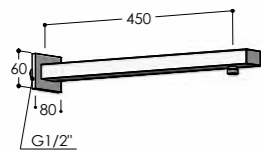

SA.Q

Braccio doccia rettangolare
Rectangular shower arm
Bras de douche rectangulaire
Brazo rociador rectangular
Brausearm, rechteckig

SA.Q/MX

SA.Q/BX
SA.Q/MB
SA.Q/RL
SA.Q/BB
SA.Q/BC
SA.Q/AB
SA.Q/DB

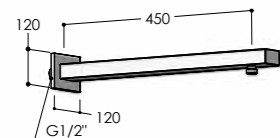

SA.QB

Braccio doccia rettangolare
Rectangular shower arm
Bras de douche rectangulaire
Brazo rociador rectangular
Brausearm, rechteckig

SA.QB/MX

SA.QB/BX
SA.QB/MB
SA.QB/RL
SA.QB/BB
SA.QB/BC
SA.QB/AB
SA.QB/DB

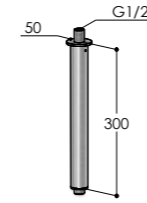

SC.R

Braccio doccia a soffitto, tondo
Ceiling-mounted shower arm, round
Bras de douche de plafond, rond
Brazo rociador de techo, redondo
Deckenhalter für Kopfbrause, rund

SC.R/MX

SC.R/BX
SC.R/MB
SC.R/RL
SC.R/BB
SC.R/BC
SC.R/AB
SC.R/DB

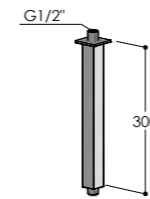

SC.Q

Braccio doccia a soffitto, quadrato
Ceiling-mounted shower arm, square
Bras de douche de plafond, carré
Brazo rociador de techo, cuadro
Deckenhalter für Kopfbrause, viereckig

SC.Q/MX

SC.Q/BX
SC.Q/MB
SC.Q/RL
SC.Q/BB
SC.Q/BC
SC.Q/AB
SC.Q/DB



W100

Scarico per lavabo, con tappo a pressione
Pushbutton waste for washbasin
Vidage à pression pour lavabo
Válvula de desagüe click clack
Pushdown Waschtisch-Ablaufgarnitur

W100/MX

W100/BX
W100/MB
W100/RL
W100/BB
W100/BC
W100/AB
W100/DB

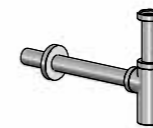

W200

Sifone da lavabo
Washbasin trap
Siphon pour lavabo
Sifón para lavabo
Waschtischsiphon

W200/MX

W200/BX
W200/MB
W200/RL
W200/BB
W200/BC
W200/AB
W200/DB



RE10

Rubinetto esterno per colonne doccia, acciaio inox Aisi 316

External tap for shower columns, inox steel Aisi 316

Robinet extérieur pour colonnes douche, acier

Grifo exterior para columnas ducha, acero inox Aisi 316

Aussen-Wasserhahn für Brausesäulen, Edelstahl Aisi 316

RE10/MX

RE10/BX

RE10/MB

RE10/RL



RE10.L

Rubinetto esterno per colonne doccia, acciaio inox Aisi 316

External tap for shower columns, inox steel Aisi 316

Robinet extérieur pour colonnes douche, acier

Grifo exterior para columnas ducha, acero inox Aisi 316

Aussen-Wasserhahn für Brausesäulen, Edelstahl Aisi 316

RE10.L/MX

RE10.L/BX

RE10.L/MB

RE10.L/RL



RE10.HB

Rubinetto esterno per colonne doccia, acciaio inox Aisi 316 con raccordo portagomma

External tap for shower columns, inox steel Aisi 316 with hose connection

Robinet extérieur pour colonnes douche, acier inox Aisi 316 avec raccord cannelé

Grifo exterior para columnas ducha, acero inox Aisi 316 con racor manguera

Aussen-Wasserhahn für Brausesäulen, Edelstahl Aisi 316 mit Anschluß für Gartenschlauch

RE10.HB/MX

RE10.HB/BX

RE10.HB/MB

RE10.HB/RL



RE10.HB.L

Rubinetto esterno per colonne doccia, acciaio inox Aisi 316 con raccordo portagomma

External tap for shower columns, inox steel Aisi 316 with hose connection

Robinet extérieur pour colonnes douche, acier inox Aisi 316 avec raccord cannelé

Grifo exterior para columnas ducha, acero inox Aisi 316 con racor manguera

Aussen-Wasserhahn für Brausesäulen, Edelstahl Aisi 316 mit Anschluß für Gartenschlauch

RE10.HB.L/MX

RE10.HB.L/BX

RE10.HB.L/MB

RE10.HB.L/RL



RE10.FS

Rubinetto esterno per colonne doccia, acciaio inox Aisi 316 con soffione lavapiedi S03

External tap for shower columns, inox steel Aisi 316 with foot shower S03

Robinet extérieur pour colonnes douche, acier inox Aisi 316 avec douchette rince-pieds S03

Grifo exterior para columnas ducha, acero inox Aisi 316 con ducha lava pies S03

Aussen-Wasserhahn für Brausesäulen, Edelstahl Aisi 316 mit Fußbrause S03

RE10.FS/MX

RE10.FS/BX

RE10.FS/MB

RE10.FS/RL



RE10.FS.L

Rubinetto esterno per colonne doccia, acciaio inox Aisi 316 con soffione lavapiedi S03

External tap for shower columns, inox steel Aisi 316 with foot shower S03

Robinet extérieur pour colonnes douche, acier inox Aisi 316 avec douchette rince-pieds S03

Grifo exterior para columnas ducha, acero inox Aisi 316 con ducha lava pies S03

Aussen-Wasserhahn für Brausesäulen, Edelstahl Aisi 316 mit Fußbrause S03

RE10.FS.L/MX

RE10.FS.L/BX

RE10.FS.L/MB

RE10.FS.L/RL



RE12.AST

Rubinetto temporizzato a pressione acciaio inox Aisi 316

Push-button time-limited tap, stainless steel Aisi 316

Robinet temporisé poussoir acier inoxydable Aisi 316

Grifo con pulsador temporizado acero inoxidable Aisi 316

Selbstschließender Hahn mit Druckknopf Edelstahl Aisi 316

RE12.AST/MX

RE12.AST/BX

RE12.AST/MB

RE12.AST/RL



RE12.AST.FS

Rubinetto temporizzato a pressione acciaio inox Aisi 316 con soffione lavapiedi S03

Push-button time-limited tap, stainless steel Aisi 316 with foot shower S03

Robinet temporisé poussoir acier inox Aisi 316 avec douchette rince-pieds S03

Grifo con pulsador temporizado acero inox Aisi 316 con ducha lava pies S03

Selbstschließender Hahn mit Druckknopf Edelstahl Aisi 316 mit Fußbrause S03

RE12.AST.FS/MX

RE12.AST.FS/BX

RE12.AST.FS/MB

RE12.AST.FS/RL



RE04.L

Rubinetto esterno per colonne doccia Origo Rame, ottone lucido naturale

External tap for shower columns Origo Rame, polished brass

Robinet extérieur pour colonnes douche Origo Rame, laiton poli

Grifo exterior para columnas ducha Origo Rame, latón pulido

Aussen-Wasserhahn für Origo Rame Brausesäulen, Messing poliert

RE04.L

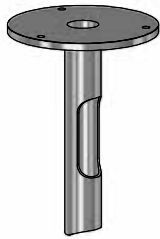

XT200

Innesto per fissaggio a terreno, con base \varnothing 200 mm, acciaio inox Aisi 316

Extension stem for installation on ground, with \varnothing 200 mm flange, inox steel Aisi 316

Tige de rallonge pour installation au sol, avec embase \varnothing 200 mm, acier inox Aisi 316

Tubo prolongador para instalación sobre tierra, con base \varnothing 200 mm, acero inox Aisi 316

Verlängerungsrohr für Bodeinbau, mit Sockel \varnothing 200 mm, Edelstahl Aisi 316

XT200.1

XT200.2

€ 300,00

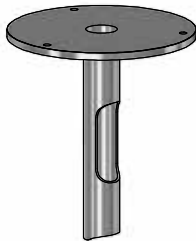

XT250

Innesto per fissaggio a terreno, con base \varnothing 250 mm, acciaio inox Aisi 316

Extension stem for installation on ground, with \varnothing 250 mm flange, inox steel Aisi 316

Tige de rallonge pour installation au sol, avec embase \varnothing 250 mm, acier inox Aisi 316

Tubo prolongador para instalación sobre tierra, con base \varnothing 250 mm, acero inox Aisi 316

Verlängerungsrohr für Bodeinbau, mit Sockel \varnothing 250 mm, Edelstahl Aisi 316

XT250.1

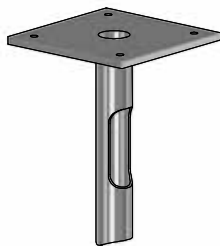

XQ200

Innesto per fissaggio a terreno, con base 200x200 mm, acciaio inox Aisi 316

Extension stem for installation on ground, with 200x200 mm flange, inox steel Aisi 316

Tige de rallonge pour installation au sol, avec embase 200x200 mm, acier inox Aisi 316

Tubo prolongador para instalación sobre tierra, con base 200x200 mm, acero inox Aisi 316

Verlängerungsrohr für Bodeinbau, mit Sockel 200x200 mm, Edelstahl Aisi 316

XQ200.1

XQ200.2

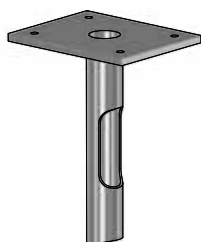

XQ200.A

Innesto per fissaggio a terreno, con base 200x160 mm, acciaio inox Aisi 316

Extension stem for installation on ground, with 200x160 mm flange, inox steel Aisi 316

Tige de rallonge pour installation au sol, avec embase 200x160 mm, acier inox Aisi 316

Tubo prolongador para instalación sobre tierra, con base 200x160 mm, acero inox Aisi 316

Verlängerungsrohr für Bodeinbau, mit Sockel 200x160 mm, Edelstahl Aisi 316

XQ200.A.1

XQ200.A.2



CONCEALED BODIES AND INSTALLATIONS

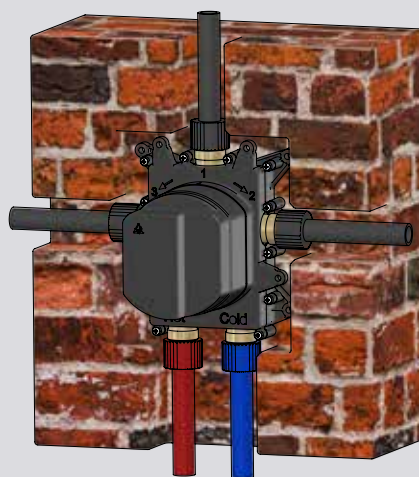

Concealed bodies *pag. 210*

Installations *pag. 213*

CONCEALED BODIES
AND INSTALLATIONS

CONCEALED BODIES AND INSTALLATIONS

W3P.INC

Lavabo
Basin
Lavabo
Lavabo
Waschtisch

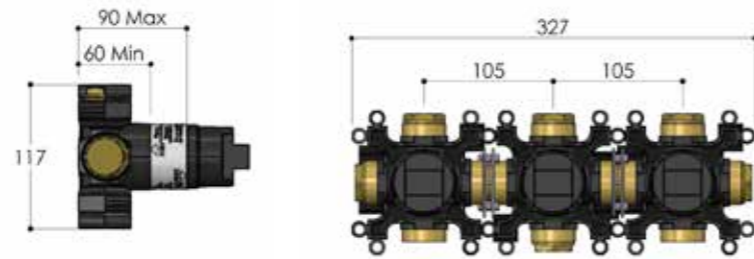

CONCEALED BODIES AND INSTALLATIONS

W4MP.INC

Vasca
Bathtub
Baignoire
Bañera
Badewanne

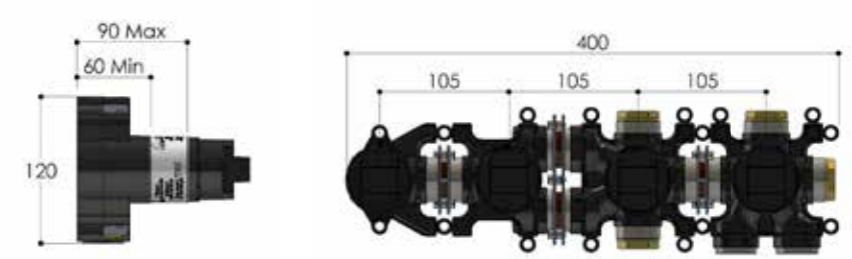

W2MP.INC

Lavabo_Vasca
Basin_Bathtub
Lavabo_Baignoire
Lavabo_Bañera
Waschtisch_Badewanne

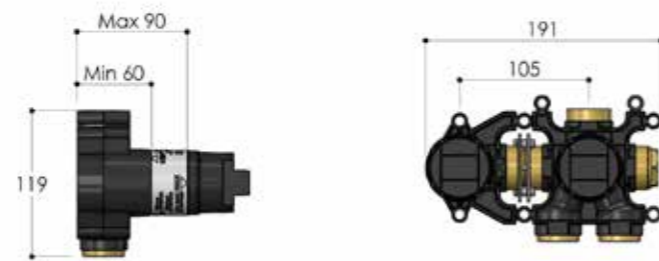

ST.INC

Doccia
Shower
Douche
Ducha
Dusche

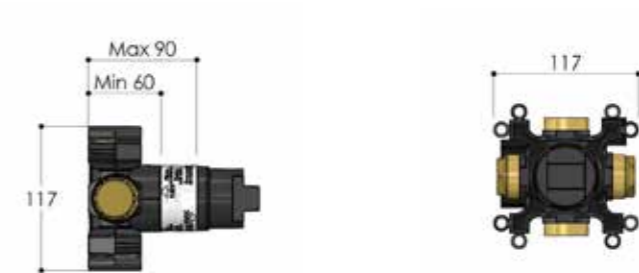

MR.INC

Lavabo_Doccia
Basin_Shower
Lavabo_Douche
Lavabo_Ducha
Waschtisch_Dusche



MR2.INC

Doccia
Shower
Douche
Ducha
Dusche

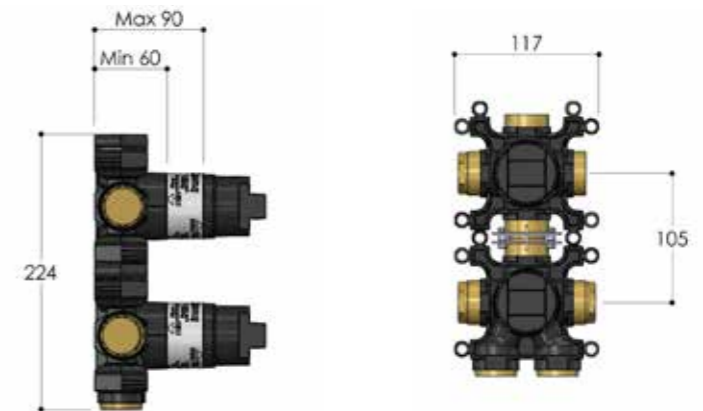

W3MP.INC

Vasca
Bathtub
Baignoire
Bañera
Badewanne



MR3.INC

Doccia
Shower
Douche
Ducha
Dusche

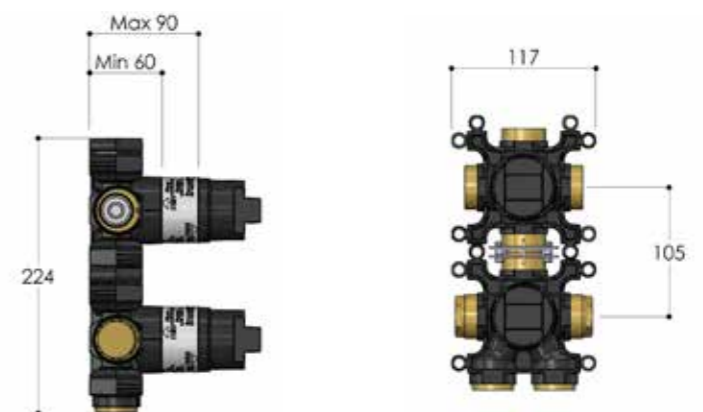

CONCEALED BODIES AND INSTALLATIONS

MX.INC

Doccia
Shower
Douche
Ducha
Dusche

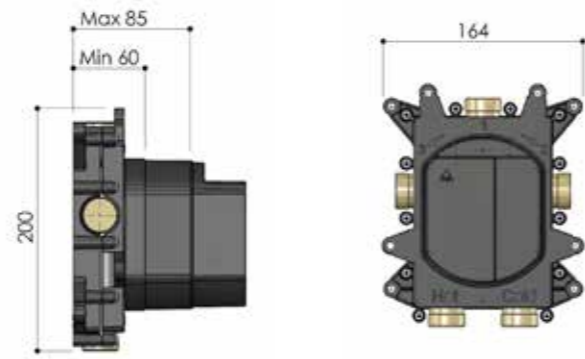

HF1.INC

Doccia
Shower
Douche
Ducha
Dusche

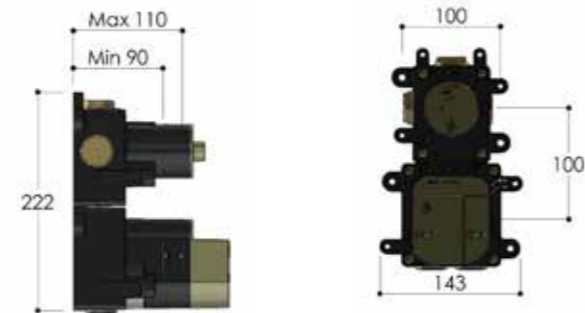

HF2.INC

Doccia
Shower
Douche
Ducha
Dusche

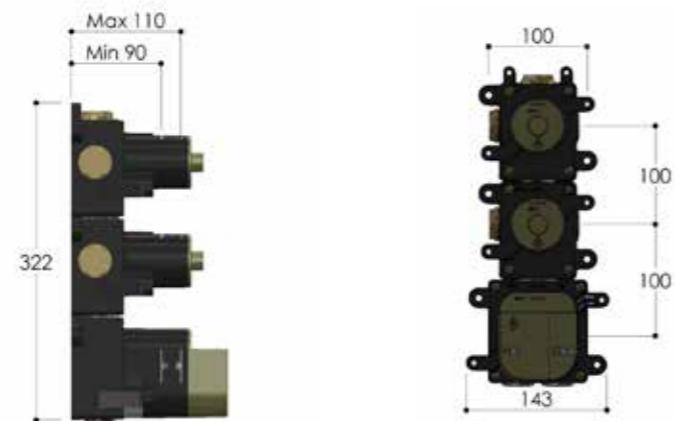

HF3.INC

Doccia
Shower
Douche
Ducha
Dusche

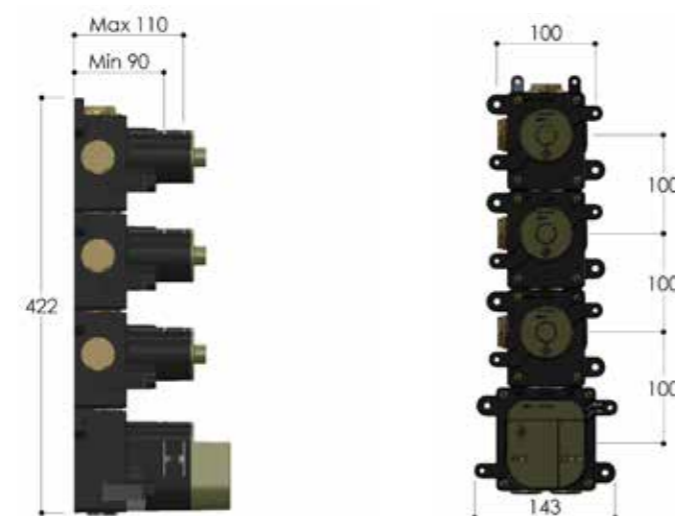

CONCEALED BODIES AND INSTALLATIONS

HF4.INC

Doccia
Shower
Douche
Ducha
Dusche

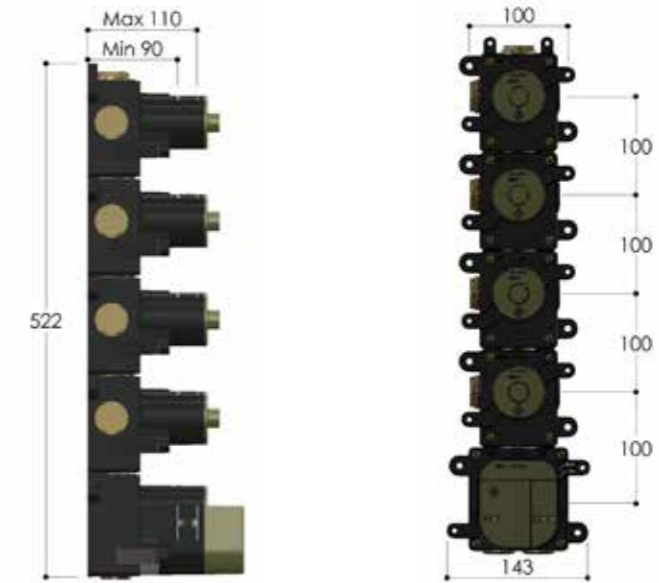

CW.1 – CW.2

Lavabo_Vasca_Doccia
Basin_Bathtub_Shower
Lavabo_Baignoire_Douche
Lavabo_Bañera_Ducha
Waschfisch_Badewanne_Dusche

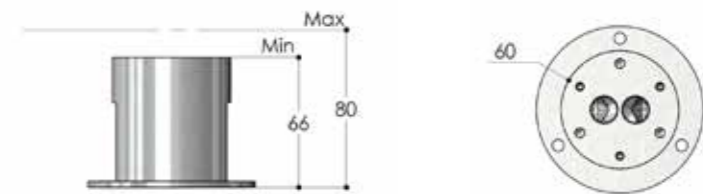

CW

Installazione idrica ad incasso | Concealed water supply | Alimentation en eau encastrée
Con alimentación empotrada del agua | Einabu mit Unterputzwasserversorgung

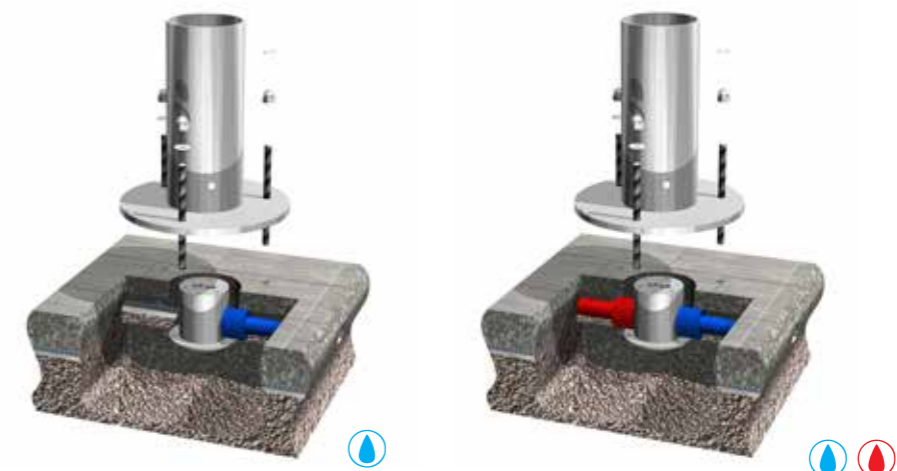

CONCEALED BODIES AND INSTALLATIONS

✓ STANDARD

Installazione standard | Standard installation | Installation standard | Instalación estándar | Standard Einabu

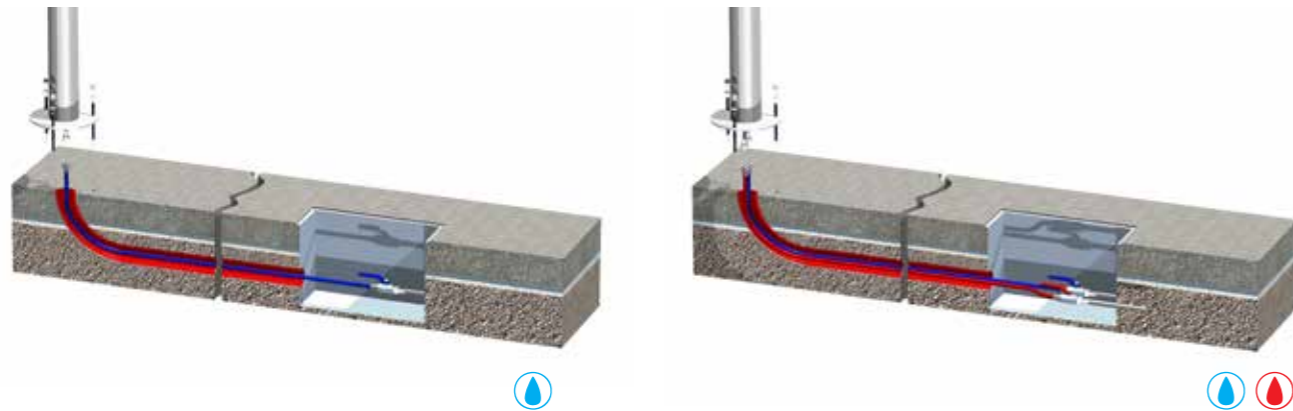

EW

Alimentazione idrica esterna | External water supply | Alimentation en eau extérieure
Alimentación externa del agua | Einabu mit Außenwasserversorgung



Standard+ XT-XQ-XQ.A

pag 208



CONCEALED BODIES AND INSTALLATIONS

4S

Antigelo | No-frost | Antigel | Antihielo | Frostschutz

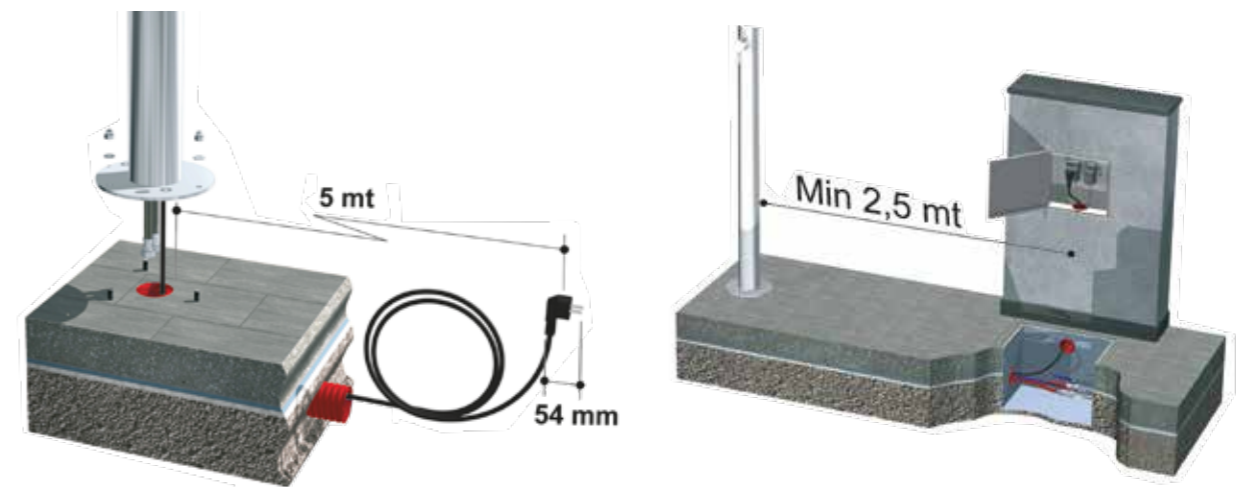

TECHNICAL INFO

Voltage:	230V
Output at 5°C:	19,63 W/m – 68,70 W
Temperature ON/OFF:	+3°C/+9°C
Minimum operating temperature:	-20°C
Protection rating:	IP X7
Length of heating cable:	3,5 mts (7 mm)
Length of cold cable:	5 mts (3 x 1,5)
Typ Etherma:	Fontealta-3,5

Il cablaggio riscaldante impedisce il congelamento delle tubazioni e degli apparati interni alla colonna (corpo miscelatore, rubinetto e deviatore). Gli apparati esterni alla colonna (doccette, flessibili, rubinetti da giardino e soffioni) non sono cablati e quindi non sono protetti dal congelamento.

The heating wiring prevents the freezing of pipes and components inside the column (mixer, tap and diverter bodies).

The external components (handshowers, hoses, garden taps and showerheads) are not wired and therefore not protected against freezing.

Le câblage chauffant empêche le gel des tuyaux et des composants à l'intérieur de la colonne (corps du mélangeur, robinet et déviateur).

Les composants extérieurs (douchettes, flexibles, robinets de jardin et pommes de douche) ne sont pas câblés et par conséquent pas protégés contre le gel.



El cableado de calefacción evita la congelación de las tuberías y de los componentes en el interior de la columna (cuerpo del mezclador, del grifo y del desviador).

Los componentes externos (grifos de mano, flexibles, grifos de jardín y rociadores) no están cableados y, por tanto, no están protegidos contra la congelación.

Die Heizungsverkabelung verhindert das Einfrieren der Rohre und Komponenten im Inneren der Säule (Mischer-, Armaturen- und Umleitungskörper).

Die externen Komponenten (Handbrausen, Schläuche, Gartenarmaturen und Duschköpfe) sind nicht verkabelt und daher nicht vor dem Einfrieren geschützt.

INDICE | INDEX | INDICE | ÍNDICE | INDEX

4S	215	C50R	132	F50H	10	P22.M	149	S60V.HF.M	34	W2MBP.O	103	W9X1.E	110	W683	46
B40L	73	C50R.E	132	F60L.M	13	P22.ME	149	S60V.HF.ME	34	W2MBP.Y	57	W10	152	W683.E	46
B40L.M	73	C50R.M	133	F60L.RC	13	P22.S	149	SA21.06	184	W2MB.Y	56	W010	179	W730	37
B40L.RC	73	C50R.ME	133	F60.M	23	P60	167	SA33.10	184	W2M.CD	71	W010.E	179	W730.E	37
B40V	76	C50R.RC	132	F60.ME	23	PQ80	167	SA35.F	184	W2M.F	11	W10.FS	153	W732	38
B40V.E	76	C60V.HF.M	106	F60.RC	23	PQ80.2	167	SA40	184	W2M.L	27	W10.FS.L	153	W732.E	38
B40V.M	77	C60V.HF.ME	106	F60V.M	16	PS03	198	SA40.12	184	W2M.O	99	W10.HB	152	W775.E	39
B40V.ME	77	C90	120	F60V.ME	16	PS04	198	SA53.07	185	W2MP.2.CD	71	W10.HB.L	152	W783	39
B40V.RC	76	C90.AST	159	F60V.RC	16	PS05	198	SA53.09	185	W2MP.2.F	11	W10.L	152	W783.E	39
B60V.HF.M	78	C90.E	120	FLX02	200	PS09	198	SA53.11	185	W2MP.2.L	27	W012	180	W810	63
B60V.HF.ME	78	C90.M	121	FLX03	200	PS10	198	SA53.15	185	W2MP.2.O	99	W12.AST	164	W810.E	63
B76	85	C90.ME	121	FLX04	200	Q53	140	SA150.S	185	W2MP.2.Y	53	W12.AST.FS	164	W812	64
B76.2	86	C90.RC	120	FLX06	200	Q53.E	140	SA150.SC	186	W2MP.CD	71	W012.E	180	W812.E	64
B76.2E	86	C140.2	165	FLX07	201	Q53.M	141	SA300.C	186	W2MP.F	11	W15A6.E	118	W875.E	65
B76.AST	158	C140.3	166	FLX08	201	Q53.ME	141	SA300.SC	186	W2MP.INC	210	W18.AST	162	W883	65
B76.E	85	C140.4	166	HF1.INC	212	Q53.RC	140	SA.Q	204	W2MP.L	27	W25A6.E	126	W883.E	65
B76.M	86	C140.AST.2	165	HF2.INC	212	Q53.YCWS.M	195	SA.QB	204	W2MP.O	99	W28.AST	162	W920	109
B76.ME	87	C140.AST.3	166	HF3.INC	212	Q53.YCWS.ME	195	SA.R	204	W2MP.Y	53	W30	52	W920.E	109
B76.RC	85	C140.AST.4	166	HF4.INC	213	Q53.YEWS.M	195	SA.RB	204	W2M.Y	53	W30B	52	W922	110
BJ.02	186	CD35	70	K1M.LT	174	Q53.YEWS.ME	195	SA.RC	204	W2X7	124	W30H	52	W922.E	110
BJ.04	186	CD35B	70	K2M.CD	171	Q86	144	SB	183	W3B.CD	74	W34A6.E	83	W975.E	111
BW50.YCWS.M	193	CD35H	70	K2M.L	171	Q86.2	165	SB.SLIM	183	W3B.F	14	W35	26	W983	111
BW50.YCWS.M.D	194	CL90	128	K2M.LT	174	Q86.AST	159	SC.Q	205	W3B.F	1	W35B	26	W983.E	111
BW50.YCWS.ME	194	CL90.AST	159	K2M.LTS	174	Q86.AST.2	165	SC.R	205	W3B.L	30	W35H	26	WF.01	187
BW50.YCWS.ME.D	194	CL90.E	128	K2M.O	171	Q86.E	144	SK	182	W3B.O	102	W35.M	153	WF.02	187
BW50.YEWS.M	193	CL90.M	129	K2M.Y	171	Q86.M	145	SK.10	182	W3B.Y	56	W35.M.AST	164	WMRL	12
BW50.YEWS.M.D	194	CL90.ME	129	K35.CD	170	Q86.ME	145	SP.CD	72	W3.CD	70	W38.AST	163	W40	98
BW50.YEWS.ME	194	CL90.RC	128	K35.L	170	Q86.RC	144	SP.F	12	W3.F	10	W40B	98	WMRL	54
BW50.YEWS.ME.D	194	COL30	154	K35.O	170	Q120	165	SP.L	28	W3.L	26	W40H	98	WMRL	72
BW76	94	COL30.G	154	K35.S	173	Q120.AST	165	SP.O	100	W3MBP.CD	75	W44A6.E	92	WMRL	100
BW76.2	95	COL30.H	154	K35.Y	170	Q380	187	SP.Y	54	W3MBP.F	15	W48.AST	163	WX4A6.SK	84
BW76.2E	95	COL50.YCWS.M	195	K40.LS	173	Q380.C	187	SR	182	W3MBP.L	31	W56A6.E	21	WX4A6.SK	93
BW76.AST	158	COL50.YEWS.M	195	K40.OS	173	Q380.DF	187	SR.SLIM	183	W3MBP.O	103	W68.AST	161	WX5A6.SK	119
BW76.E	94	COL90	155	KW30	172	Q500	188	ST1	176	W3MBP.Y	57	W075.E	181	WX5A6.SK	127
BW76.M	95	COL90.2	156	KW50	172	Q500.DF	188	ST1.L	176	W3MP.INC	210	W78.AST	161	WX6A6.SK	22
BW76.ME	96	COL90.AST	160	KW50.UP	172	R700	188	Standard+ XT-XQ-XQ.A	214	W3.O	98	W083	181	WX8.AST.SK	164
BW76.RC	94	COL90.AST.L	160	MR	17	R700.DF	188	ST.CD	79	W3P.CD	71	W083.E	181	WX10.SK	66
C40	48	COL90.L	156	MR	35	RE04.L	207	ST.F	17	W3P.F	11	W88.AST	161	WX12.SK	66
C40.E	48	COL90.M	155	MR	61	RE10	206	ST.INC	211	W3P.INC	210	W98.AST	162	WX20.SK	112
C40L	101	COL90.R	155	MR	79	RE10.FS	206	ST.L	35	W3P.L	27	W100	205	WX22.SK	112
C40L.M	101	CS40L	55	MR	107	RE10.FS.L	207	ST.O	107	W3P.O	99	W154	116	WX30.SK	40
C40L.RC	101	CS40L.M	55	MR1	177	RE10.HB	206	ST.Y	61	W3P.Y	53	W154.E	116	WX30.SK	47
C40.M	49	CS40L.RC	55	MR2	177	RE10.HB.L	206	TC1.CD	80	W3X7	81	W157C	117	WX32.SK	40
C40.ME	49	CS40V	58	MR2.CD	79	RE10.L	206	TC1.F	18	W3.Y	52	W159C.E	117	WX32.SK	47
C40.RC	48	CS40V.E	58	MR2.F	17	RE12.AST	207	TC1.L	36	W4MB.CD	74	W200	205	WX44.SK	84
C40V	104	CS40V.M	59	MR2.INC	211	RE12.AST.FS	207	TC1.O	108	W4MB.F	14	W254	124	WX44.SK	93
C40V.E	104	CS40V.ME	59	MR2.L	35	S02.ABS	201	TC1.Y	62	W4MB.F	1	W254.E	124	WX47C.SK	84
C40V.M	105	CS40V.RC	58	MR2.O	107	S03	201	TC2.CD	80	W4MB.L	30	W257C	125	WX47C.SK	93
C40V.ME	105	CS60V.HF.M	60	MR2.Y	61	S04	201	TC2.F	18	W4MB.O	102	W259C.E	125	WX47C.SK.K	182
C40V.RC	104	CS60V.HF.ME	60	MR3.CD	79	S05	202	TC2.L	36	W4MBP.CD	75	W259.E	125	WX54.SK	119
C40.YCWS.M	192	CSR40	67	MR3.F	17	S06	202	TC2.O	108	W4MBP.F	15	W344	81	WX57C.SK	119
C40.YCWS.M.D	192	CSR40.E	67	MR3.INC	211	S07	202	TC2.Y	62	W4MBP.L	31	W344.E	81	WX67C.SK	22
C40.YCWS.ME	193	CSR40.M	68	MR3.L	35	S08	202	TC3.CD	80	W4MBP.O	103	W444	90	WX75.SK	40
C40.YCWS.ME.D	193	CSR40.ME	68	MR3.O	107	S09	202	TC3.F	18	W4MBP.Y	57	W444.E	90	WX75.SK	47
C40.YEWS.M	192	CSR40.RC	67	MR3.Y	61	S10	203	TC3.L	36	W4MB.Y	56	W447C	91	WX75.SK	66
C40.YEWS.M.D	192	CW	213	MR.INC	210	S11	203	TC3.O	108	W4MP.INC	211	W449C.E	91	WX75.SK	112
C40.YEWS.ME	193	CW.1 - CW.2	213	MRL	176	S12	203	TC3.Y	62	W4X7	90	W449.E	91	WX83.SK	40
C40.YEWS.ME.D	193	D3	176	MX2.CD	80	S15	203	TC.HF1	177	W5B.CD	74	W564	19	WX83.SK	47
C50AS	113	D03.Q	199	MX2.F	18	S16	203	TC.HF2	177	W5B.F	14	W564.E	19	WX83.SK	66
C50AS.AST	158	D04	199	MX2.L	36	S40	41	TC.HF3	178	W5B.F	1	W567C	20	WX83.SK	112
C50AS.E	113	D06	199	MX2.O	108	S40.E	41	TC.HF4	178	W5B.L	30	W569C.E	20	XQ200	208
C50AS.M	114	D10	199	MX2.Y	62	S40L	29	W0X1	179	W5B.O	102	W630	44	XQ200.A	208
C50AS.ME	114	D12	199	MX3.CD	80	S40L.M	29	W0X1.E	180	W5B.Y	56	W630.E	44	XT200	208
C50AS.RC	113	D14.K	200	MX3.F	18	S40L.RC	29	W1X7	116	W5X7	19	W632	45	XT250	208
C50AS.YCWS.M	191	D50	136	MX3.L	36	S40.M	42	W2MB.CD	74	W6X1	44	W632.E	45	YCWS	190
C50AS.YCWS.M.D	191	D50.E	136	MX3.O	108	S40.ME	42	W2MB.F	14	W6X1.E	45	W675.E	46	YEWS	190
C50AS.YCWS.ME	191	D50.M	137	MX3.Y	62	S40.RC	41	W2MB.F	1	W7X1	37				
C50AS.YCWS.ME.D	192	D50.ME	137	MX.INC	212	S40V	32	W2MB.L	30	W7X1.E	38				
C50AS.YEWS.M.D	191	D50.RC	136	P9	148	S40V.E	32	W2MB.O	102	W08.AST	163				
C50AS.YEWS.ME.D	192	EW	214	P22	148	S40V.M	33	W2MBP.CD	75	W8X1	63				
C50AS.YEWS.ME.D	192	F50	10	P22.AST	160	S40V.ME	33	W2MBP.F	15	W8X1.E	64				
		F50B	10	P22.E	148	S40V.RC	32	W2MBP.L	31	W9X1	109				

CONDIZIONI DI VENDITA E GARANZIA

1. Ai prezzi del listino Fontealta deve essere applicata l'IVA secondo l'aliquota in vigore al momento della fatturazione. Il produttore si riserva di modificare i prezzi, o variare il listino prezzi senza alcun preavviso.

2. Con la trasmissione della proposta d'ordine il rivenditore accetta tutte le nostre condizioni di vendita e di consegna elencate qui di seguito. L'ordine è vincolante per il rivenditore mentre impegna la Rubinetteria F&F L'Artigiana srl solo dopo l'emissione della conferma d'ordine.

3. Salvo patto contrario, la fornitura dei prodotti si intende Franco Fabbrica del produttore; trasporto ed assicurazione sono pertanto a carico del rivenditore e ciò anche quando sia convenuto che la spedizione venga curata dal produttore, nel qual caso quest'ultimo agirà come mandatario del rivenditore, essendo inteso che il trasporto verrà effettuato a rischio del rivenditore. I rischi relativi alla fornitura passano al rivenditore al momento in cui i prodotti lasciano lo stabilimento del produttore.

4. Qualsiasi sia l'accordo tra produttore e rivenditore sul trasporto dei prodotti, il controllo delle quantità e gli eventuali rilievi di difformità dovranno essere segnalati entro otto giorni dal ricevimento della merce. Il destinatario è obbligato a controllare la merce in arrivo ed a contestare subito gli eventuali danni direttamente al trasportatore che ne è responsabile. E' diritto del destinatario e dovere del trasportatore controllare la spedizione e apporre le eventuali riserve specifiche sul Documento di Trasporto. La sola dicitura generica "RISERVA DI CONTROLLO" non è valida.

5. La Rubinetteria F&F L'Artigiana garantisce i propri prodotti, e la loro conformità, per 24 mesi a decorrere dalla data di consegna, comunque entro i limiti del DPR 222/224 24/05/88 e secondo le Direttive Europee vigenti. Per conformità dei prodotti si intende che essi corrispondono per qualità, quantità e tipo a quanto stabilito nel contratto e che sono esenti da vizi che potrebbero renderli non idonei all'uso cui sono destinati. La garanzia dei prodotti per vizi, è limitata ai soli difetti del materiale o di costruzione riconducibili al produttore.

6. La garanzia dei prodotti sarà applicabile alle seguenti condizioni:

- Lo scontrino od altra prova di vendita devono essere conservati dall'acquirente.
- La richiesta di sostituzione/riparazione accompagnata dalla documentazione deve essere effettuata tramite rivenditore presso il quale il prodotto è stato acquistato
- Il materiale difettoso dovrà pervenire alla nostra sede in porto franco.
- Al ricevimento il materiale sarà immediatamente controllato; qualora il reclamo sia ritenuto fondato la sostituzione sarà effettuata e resa franco destino. In caso di infondatezza, le motivazioni saranno dichiarate con il mezzo di comunicazione ritenuto più idoneo e tempestivo.

7. La garanzia decade automaticamente nei seguenti casi:

- Se il prodotto non è stato installato da personale qualificato e/o non sia stato rilasciato certificato di collaudo .
- Se l'acquirente non provvede in modo accurato alla manutenzione ordinaria e straordinaria, come indicato dal produttore nei libretti di installazione.
- Se il prodotto è stato manomesso da parte dell'utilizzatore.
- Se il vizio di funzionamento è conseguente ad un intervento sul prodotto non autorizzato.

8. Qualsiasi ritardo o irregolarità nei pagamenti dà al produttore il diritto di sospendere le forniture, risolvere i contratti in corso e qualsiasi tipo di condizione commerciale. Farà fede unicamente il prezzo espresso nel listino al pubblico in vigore alla data della conferma d'ordine. Dalla scadenza del pagamento, il produttore ha diritto a far decorrere gli interessi moratori secondo la normativa vigente. Il ritardo nei pagamenti dà altresì al produttore il diritto di escludere la garanzia per tutto il periodo durante il quale il ritardo perdura.

9. La Rubinetteria F&F L'Artigiana srl si riserva di apportare modifiche tecniche ed estetiche ai propri prodotti in qualsiasi momento senza preavviso.

10. Per qualsiasi controversia è competente unicamente il Foro di LUCCA

11. Ai sensi del DL196/2003 La Rubinetteria F&F L'Artigiana srl dichiara che i dati messi a disposizione dal committente verranno elaborati in rispetto della legge sulla tutela della privacy.

12. Tutte le suddette condizioni di vendita si intendono integralmente accettate con il conferimento dell'ordine.

SALE AND WARRANTY CONDITIONS

1. The Fontealta list prices are subject to the application of VAT at the rate in force at the time of billing. The manufacturer reserves the right to change the prices or the pricelist without prior notice.

2. With the transmission of the order proposal, the retailer accepts all our sales and delivery conditions, as listed hereafter. The order is binding for the retailer, while Rubinetteria F&F L'Artigiana srl is only subject to its terms after issue of the order confirmation.

3. Unless otherwise agreed, the supply of the products is intended ex-works. Consequently, transport and insurance are the retailer's responsibility, even when it is agreed that delivery shall be taken care of by the manufacturer, in which case the latter shall act as the retailer's delegate, on the understanding that the goods shall be carried at the retailer's risk. Risks relating to supply shall be transferred to the retailer when the products leave the manufacturer's premises.

4. Whatever the agreement between the manufacturer and the retailer governing the transport of the products, quality control must be carried out and any faults reported within eight days of receipt of the goods. The addressee is obliged to check incoming goods and present complaints regarding any damages directly to the transporter, who is responsible for them. The addressee is entitled and the transporter is obliged to check the delivery and indicate any reservations on the Delivery Document. The wording "WE RESERVE THE RIGHT TO CHECK" is not sufficient.

5. Rubinetteria F&F L'Artigiana srl guarantees its products and their conformity for 24 months from the delivery date, within the limits of DPR 222/224 24/05/88 and in compliance with the European Directives in force. Product conformity means the correspondence in terms of quality, quantity and type to that stated in the agreement and that the products are free from faults which might make them unsuitable for the purpose for which they were created. The product fault warranty is limited to faults in the material or construction which can be traced back to the manufacturer.

6. The product warranty shall be applicable at the following conditions:

- the receipt or other proof of purchase must be kept by the buyer;
- the request for replacement/repair accompanied by documentation must be presented to the retailer where the product was purchased;
- faulty material must be delivered free to our premises;
- the material will be checked immediately upon receipt. Should the complaint be founded, the product will be replaced and delivered free to destination. If the complaint is not founded, the reasons will be declared using the quickest and most appropriate means of communication.

7. The warranty shall automatically cease to be valid in the following cases:

- if the product has not been installed by qualified personnel and/or no test certificate has been issued;
- if the buyer does not carry out the necessary ordinary and special maintenance, as indicated in the installation booklet;
- if the product has been interfered with by the user;
- if the operating fault is due to unauthorised intervention on the product.

8. Any delay or irregularity in payments shall entitle the manufacturer to suspend supplies or to terminate the agreements in progress. From the expiry of payment, the manufacturer is entitled to apply interest on arrears in compliance with the legislation in force. Delayed payment also entitles the manufacturer to withdraw the warranty for the duration of the arrears.

9. Rubinetteria F&F L'Artigiana srl reserves the right to make technical and aesthetic changes to its products at any time, without prior notice.

10. Any dispute shall be under the exclusive jurisdiction of the Court of LUCCA.

11. In compliance with Legislative Decree 196/2003, Rubinetteria F&F L'Artigiana srl hereby declares that the data made available by the customer shall be processed in observance of the law on the defence of privacy.

12. All the above sales conditions are considered as accepted in full with transmission of an order.

CONDITIONS DE VENDE ET DE GARANTIE

1. Les prix de la liste Fontealta ne comprennent pas la TVA, qui doit être ajoutée selon le taux en vigueur au moment de la facturation. Le fabricant se réserve le droit de modifier les prix ou la liste des prix sans aucun préavis.

2. En transmettant la proposition de commande, le revendeur accepte toutes les conditions de vente et de livraison mentionnées ci-après. La commande engage le revendeur tandis que Rubinetteria F&F L'Artigiana srl ne sera engagée qu'après l'émission de la confirmation de commande.

3. Sauf accord contraire, la fourniture des produits s'entend franco usine du fabricant ; le transport et l'assurance sont donc à la charge du revendeur et cela même lorsqu'il a été convenu que le fabricant se charge de la livraison ; dans ce cas, ce dernier agira en tant que mandataire du revendeur, étant entendu que le transport sera effectué aux risques du revendeur. Les risques relatifs à la fourniture sont transmis au revendeur au moment où les produits sortent de l'établissement du fabricant.

4. Quel que soit l'accord entre le fabricant et le revendeur sur le transport des produits, la non-correspondance des quantités et les éventuels défauts du matériel observés devront être communiqués dans un délai de huit jours à compter de la réception de la marchandise. Le destinataire a l'obligation de contrôler la marchandise reçue et de signaler tout de suite les éventuels dommages directement au transporteur, qui en est responsable. Le destinataire a le droit et le transporteur le devoir de contrôler la marchandise et émettre les éventuelles réserves qui s'imposent sur le Document de Transport. La mention générique « SOUS RÉSERVE DE CONTRÔLE » n'a aucune valeur.

5. Rubinetteria F&F L'Artigiana srl garantit ses produits et leur conformité pendant 24 mois à compter de la date de livraison et, quoi qu'il en soit, dans les limites du DPR 222/224 24/05/88 et conformément aux Directives Européennes en vigueur.

L'expression « conformité des produits » indique que ceux-ci correspondent, en termes de qualité, quantité et type, à ce qui a été établi dans le contrat et qu'ils ne présentent pas de vices susceptibles de les rendre inappropriés à l'usage auquel ils sont destinés. La garantie des produits pour vices est limitée uniquement aux défauts du matériel ou de construction relevant du fabricant.

6. La garantie des produits sera applicable aux conditions suivantes :

- Le ticket de caisse ou toute autre preuve d'achat doivent être conservés par l'acheteur.
- La demande de substitution/réparation, accompagnée de la documentation, doit être présentée par l'intermédiaire du revendeur ayant vendu le produit.
- Le matériel défectueux devra être expédié jusqu'à notre établissement en port franco.
- À la réception, le matériel sera immédiatement contrôlé ; au cas où la réclamation sera considérée fondée, la substitution sera effectuée et la marchandise expédiée franco lieu de destination. Si la réclamation est sans fondement, les raisons en seront indiquées avec le moyen de communication considéré le plus approprié et rapide.

7. La garantie ne s'applique pas dans les cas suivants :

- Si le produit n'a pas été installé par du personnel qualifié et/ou si aucun certificat de contrôle n'a été émis.
- Si l'acheteur n'effectue pas les opérations d'entretien courant et ponctuel avec diligence, suivant ce qui est indiqué par le fabricant dans les manuels d'installation.
- Si le produit a été altéré par l'utilisateur.
- Si le défaut de fonctionnement survient suite à une intervention non autorisée sur le produit.

8. Tout retard ou irrégularité dans les paiements donne au fabricant le droit de suspendre les fournitures ou de résilier les contrats en cours. Le fabricant a le droit de prétendre les intérêts moratoires à compter de la date d'échéance du paiement, conformément à la réglementation en vigueur. En cas de retard de paiement, le fabricant a le droit d'invalider la garantie pendant la période durant laquelle le retard perdure.

9. Rubinetteria F&F L'Artigiana srl se réserve d'apporter des modifications techniques et esthétiques à ses produits à tout moment et sans préavis.

10. Pour tout litige, le Tribunal de LUCCA sera seul compétent.

11. Aux termes du DL 196/2003 Rubinetteria F&F L'Artigiana srl déclare que les données communiquées par l'acheteur seront élaborées conformément à la loi sur la protection des données personnelles.

12. Toutes les conditions de vente susdites s'entendent intégralement acceptées avec la passation de la commande.

CONDICIONES DE VENTA Y GARANTIA

1. A los precios de la lista Fontealta se debe aplicar el IVA de acuerdo a la alícuota vigente en el momento de la facturación. El fabricante se reserva el derecho de modificar los precios o de cambiar la lista de precios sin previo aviso alguno.

2. Al transmitir la propuesta de pedido, el revendedor acepta todas nuestras condiciones de venta y de entrega que se indican a continuación. El pedido es vinculante para el revendedor, mientras que obliga a Rubinetteria F&F L'Artigiana srl sólo después de la emisión de la confirmación del pedido.

3. Salvo un acuerdo en contrario, la entrega de los productos se entiende Franco Fábrica del fabricante. Por lo tanto, el transporte y el seguro están a cargo del revendedor; incluso, cuando se acuerde que el envío esté a cargo del fabricante, actuando como mandatario del revendedor, queda entendido que el transporte se realizará a riesgo del revendedor. Los riesgos correspondientes a la entrega pasan al revendedor en el momento en que los productos dejan el establecimiento del fabricante.

4. Sin importar los acuerdos entre el fabricante y el revendedor sobre el transporte de los productos, el control de la cantidad y de las eventuales deformidades deberán indicarse dentro de los ocho días de la recepción de la mercadería. El destinatario está obligado a controlar la mercadería que recibe y a reclamar inmediatamente los eventuales daños directamente al transportista responsable. El destinatario tiene el derecho y transportista el deber de controlar el envío y de presentar las eventuales reservas específicas en el Documento de Transporte. Sólo el mensaje general "RESERVA DE CONTROL" no resulta válido.

5. La empresa Rubinetteria F&F L'Artigiana garantiza la conformidad y calida de sus productos durante 24 meses a partir de la fecha de entrega y, de todas maneras, dentro de los límites del DPR italiano 222/224 del 24/05/88 y según las Directivas Europeas vigentes.

Por conformidad de los productos se entiende que los mismos corresponden en calidad, cantidad y tipo a lo establecido en el contrato y que carecen de defectos que podrían convertirlos en inadecuados para el uso al que están destinados. La garantía de los productos por defectos se limita sólo a los defectos del material o de fabricación que puedan reconocerse al fabricante.

6. La garantía de los productos se aplicará en las siguientes condiciones:

- El comprador debe conservar el recibo u otra prueba de venta.
- El pedido de sustitución o reparación acompañado por la documentación debe realizarse al revendedor a quien se adquirió el producto.
- El material defectuoso deberá llegar a nuestra sede con el porte pagado.
- Al recibir el material se lo controlará inmediatamente. Si el reclamo se considera con fundamentos, se realizará la sustitución y se la enviará pagada al domicilio del comprador. En caso de un reclamo infundado, los motivos se declararán mediante el medio de comunicación que se considere más adecuado e inmediato.

7. La garantía caducará automáticamente en los siguientes casos:

- Si el producto no fue instalado por personal cualificado o si no se emitió un certificado de conformidad del ensayo.
- Si el comprador no realiza adecuadamente el mantenimiento ordinario y extraordinario, como lo indica el fabricante en los manuales de instalación.
- Si el producto ha sido alterado por el usuario.
- Si el defecto de funcionamiento se produce después de una intervención no autorizada sobre el producto.

8. Cualquier retraso o irregularidad en los pagos proporciona al fabricante el derecho de suspender las entregas o de resolver los contratos en curso.

Al vencer el plazo de pago, el fabricante tiene el derecho de devengar los intereses moratorios según las leyes vigentes. Además, el retraso en los pagos proporciona al fabricante el derecho de excluir la garantía por todo el periodo durante el cual perdure el retraso.

9. La empresa Rubinetteria F&F L'Artigiana srl se reserva el derecho de aportar modificaciones técnicas y estéticas a sus productos en cualquier momento sin aviso previo.

10. Por cualquier controversia es competente el Fuero de LUCCA.

11. De acuerdo al decreto legislativo italiano 196/2003, la empresa Rubinetteria F&F L'Artigiana srl declara que los datos puestos a disposición por el comiteante serán procesados en el respeto de la ley sobre protección de la privacidad.

12. Las presentes condiciones de venta se entienden integralmente aceptadas con la otorgación del pedido.

VERKAUFS UND GARANTIEBEDINGUNGEN

1. Die Listenpreise von Fontealta sind Nettopreise, auf die der gesetzliche Umsatzsteuersatz aufgeschlagen wird, der zum Rechnungsdatum gilt. Der Hersteller behält sich das Recht vor, ohne Vorankündigung die Preise bzw. die Preisliste zu verändern.

2. Mit der Übermittlung der Bestellanfrage akzeptiert der Wiederverkäufer unsere im Folgenden aufgeführten Verkauf- und Lieferbedingungen. Die Bestellung ist für den Wiederverkäufer bindend, während sich die Rubinetteria F&F L'Artigiana Srl erst nach der Ausstellung der Auftragsbestätigung verpflichtet.

3. Sofern keine anderen Vereinbarungen abgeschlossen wurden, werden die Produkte ab Werk des Herstellers geliefert; Transport und Versicherung gehen daher zu Lasten des Wiederverkäufers, auch wenn vereinbart wurde, dass der Versand vom Hersteller abgewickelt wird; in diesem Fall handelt Letzterer als Bevollmächtigter des Wiederverkäufers, wobei die Transportrisiken zu Lasten des Wiederverkäufers gehen. Die Risiken der Lieferung gehen in dem Moment auf den Wiederverkäufer über, in dem die Produkte das Werk des Herstellers verlassen.

4. Unabhängig von der zwischen dem Hersteller und dem Wiederverkäufer abgeschlossenen Transportvereinbarung muss die Kontrolle bezüglich der Vollständigkeit der gelieferten Ware innerhalb einer Frist von acht Tagen ab Erhalt der Ware erfolgen; eventuelle Mängel müssen innerhalb dergenannten Frist angezeigt werden. Der Empfänger verpflichtet sich, die ankommende Ware zu kontrollieren und eventuelle Schäden sofort dem dafür verantwortlichen Spediteur anzuzeigen. Der Empfänger hat das Recht bzw. Der Spediteur die Pflicht, die Lieferung zu kontrollieren und eventuelle Vorbehalte auf dem Lieferschein zu vermerken. Eine lediglich allgemein gehaltene Angabe „PRÜFVORBEHALT“ ist nicht gültig.

5. Das Unternehmen Rubinetteria F&F L'Artigiana gewährt für seine Produkte und deren Konformität eine Garantie von 24 Monaten ab Lieferdatum, in jedem Fall innerhalb der Fristen gemäß DPR 222/224 24/05/88 und gemäß den geltenden europäischen Richtlinien. Unter Konformität der Produkte wird verstanden, dass sie bezüglich Qualität, Anzahl und Typologie den vertraglichen Vereinbarungen entsprechen und dass sie frei von Mängeln sind, die sie für ihre beabsichtigte Verwendung ungeeignet machen. Die Produktgarantie deckt nur Material- bzw. Konstruktionsmängel ab, die auf den Hersteller zurückzuführen sind.

6. Die Produktgarantie gilt unter den folgenden Bedingungen:

- Der Erwerber muss die Quittung bzw. Einen anderen Verkaufsnachweis aufbewahren.
- Die Forderung auf Ersatz bzw. Reparatur muss zusammen mit den notwendigen Dokumenten beim Wiederverkäufer eingereicht werden, bei dem das Produkt erworben wurde.
- Das schadhafte Material muss frachtfrei zu unserem Firmensitz geschickt werden.
- Das Material wird bei Erhalt umgehend kontrolliert; falls die Reklamation als fundiert angesehen wird, erfolgt eine frachtfreie Ersatzlieferung. Bei Unbegründetheit werden die Gründe angegeben; die Angabe erfolgt über den schnellsten und am besten geeigneten Kommunikationsweg.

7. Die Garantie verfällt automatisch in den folgenden Fällen:

- Wenn das Produkt nicht von Fachpersonal installiert wurde bzw. keine Abnahmebescheinigung ausgestellt wurde.
- Wenn der Erwerber die in den Installationsanleitungen aufgeführten ordentlichen und außerordentlichen Instandhaltungsarbeiten nicht sorgfältig ausführt.
- Wenn das Produkt vom Verwender nicht korrekt gehandhabt wurde.
- Wenn der Funktionsmangel auf nicht genehmigte Eingriffe am Produkt zurückzuführen ist.

8. Bei Verzögerungen bzw. Unregelmäßigkeiten der

Zulungen hat der Hersteller das Recht, die Lieferungen zu unterbrechen bzw. die laufenden Verträge zu kündigen. Nach Ablauf der vereinbarten Zahlungsfrist hat der Hersteller das Recht, Verzugszinsen gemäß den geltenden Vorschriften zu erheben. Zahlungsverzögerungen berechtigen den Hersteller darüber hinaus, die Produktgarantie über den gesamten Verzögerungszeitraum auszuschließen.

9. Das Unternehmen Rubinetteria F&F L'Artigiana Srl behält sich das Recht vor, jederzeit und ohne Vorankündigung an den eigenen Produkten technische und ästhetische Veränderungen vorzunehmen.

10. Bei Streitfällen jeder Art gilt der Gerichtsstand LUCCA

11. Gemäß Gesetzesdekret DL196/2003 erklärt La Rubinetteria F&F L'Artigiana Srl, dass die vom Käufer zur Verfügung gestellten Daten unter Beachtung des Datenschutzgesetzes behandelt werden.

12. Die oben aufgeführten Verkaufsbedingungen werden im Moment der Auftragserteilung in ihrem vollen Umfang akzeptiert.

MANUTENZIONE

Lavare frequentemente la colonna con acqua pulita e asciugare accuratamente dopo il lavaggio, al fine di evitare depositi di calcare. Rimuovere quanto prima depositi salini, incrostazioni di calcare, eventuali puntinature di ossido, pulire interstizi, accoppiamenti, viti a vista ecc.

Usare esclusivamente panni di microfibra e nel caso di finiture spazzolate seguire la direzione della finitura. Da evitare assolutamente: panni e prodotti abrasivi compresi detergenti in polvere, qualsiasi prodotto per la pulizia contenente candeggina/acido cloridrico. Non esporre mai i nostri articoli ai vapori dei prodotti acidi utilizzati per la pulizia di pavimenti e rivestimenti, neppure in ambienti all'aperto se questi sono nei pressi della colonna doccia. Nel caso di ambienti particolarmente aggressivi (spiaggia, stabilimenti balneari, in generale ambienti ad alta concentrazione salina) si raccomanda di installare unicamente prodotti con finitura lucida MX e effettuare la manutenzione della superficie con frequenza. In caso di periodi prolungati di non utilizzo si consiglia di smontare il prodotto, seguendo la sequenza inversa a quella descritta nei libretti di installazione. Qualora ciò non fosse possibile, si consiglia comunque di rimuovere tutte le parti asportabili (cartucce, viti, soffioni, aeratori, doccette, flessibili, ecc.) e di scollegare l'adduzione dell'acqua.

NOTA: Ai fini del riconoscimento della garanzia è obbligatorio installare un filtro ispezionabile a monte del prodotto.

MAINTENANCE

Wash the articles frequently with clean water and dry thoroughly after washing to avoid limescale deposits. Remove salt deposits, limescale deposits, any oxide stains as soon as possible; clean interstices, couplings, visible screws, etc. Only use microfiber cloths and in the case of brushed finishes follow the direction of the finish. To be absolutely avoided: abrasive cloths and products (including powder detergents), any cleaning product containing bleach/hydrochloric acid. Never expose our products to the vapours of acid products used for cleaning floors and walls, not even outdoors if applied close to our product. In the case of particularly aggressive environments (beaches, bathing establishments, in general environments with a high salt concentration) it is recommended to only install products with MX Supermirror finish and maintain the surface frequently. In the event of prolonged periods of non-use, it is recommended to dismantle the product, following the reverse sequence to that described in the installation handbooks. If this is not possible, it is advisable to demount all removable parts (cartridges, screws, showerheads, aerators, hoses, etc.) and to disconnect the water supply.

NOTE: In order for the warranty to be recognised, it is mandatory to install an inspectable filter upstream of the product.

MAINTENANCE

Laver fréquemment les produits à l'eau claire et les sécher soigneusement après le lavage pour éviter les dépôts de calcaire. Éliminer dès que possible les dépôts de sel, les dépôts de calcaire, les éventuelles taches d'oxyde ; nettoyer les interstices, les raccords, les vis apparentes, etc. N'utiliser que des chiffons en microfibra et dans le cas de finitions brossées, suivre le sens de la finition. À éviter absolument : chiffons et produits abrasifs (y compris les détergents en poudre), tout produit de nettoyage contenant de l'eau de Javel/acide chlorhydrique. Ne jamais exposer nos produits aux vapeurs des produits acides utilisés pour le nettoyage des sols et des murs, même à l'extérieur s'ils sont appliqués à proximité de notre produit. Dans le cas d'environnements particulièrement agressifs (plages, piscines, en général des environnements avec une forte concentration de sel), il est recommandé de n'installer que des produits en finition MX Supermirror et d'entretenir fréquemment la surface. En cas de périodes prolongées de non-utilisation, il est recommandé de démonter le produit en suivant la séquence inverse de celle décrite dans les manuels d'installation. Si cela n'est pas possible, il est conseillé de démonter toutes les parties amovibles (cartouches, vis, pommeaux de douche, aérateurs, tuyaux, etc.) et de débrancher l'alimentation en eau.

NOTE: Pour que la garantie soit reconnue, il est obligatoire d'installer un filtre inspectable en amont du produit.

MANTENIMIENTO

Lavar los productos frecuentemente con agua limpia y secar bien después del lavado para evitar depósitos de cal. Eliminar lo antes posible los depósitos de sal, cal y cualquier mancha de óxido; limpiar los intersticios, acoplamientos, tornillos visibles, etc. Utilizar únicamente paños de microfibra y, en el caso de acabados cepillados, seguir la dirección del acabado.

Evitar absolutamente: paños y productos abrasivos (incluidos detergentes en polvo), cualquier producto de limpieza que contenga lejía/acido clorhídrico. No exponer nunca nuestros productos a los vapores de productos ácidos utilizados para la limpieza de suelos y paredes, ni siquiera en el exterior si se aplican cerca de nuestro producto. En el caso de ambientes particularmente agresivos (playas, piscinas, en general ambientes con alta concentración de sal) se recomienda instalar únicamente productos en acabado MX Supermirror y realizar un mantenimiento frecuente de la superficie. En caso de períodos prolongados sin uso, se recomienda desmontar el producto, siguiendo la secuencia inversa a la descrita en los manuales de instalación. Si esto no es posible, se aconseja desmontar todas las piezas desmontables (cartuchos, tornillos, cabezales de ducha, aireadores, mangueras, etc.) y desconectar el suministro de agua.









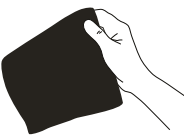

NOTA: Para que se reconozca la garantía, es obligatorio instalar un filtro inspeccionable antes del producto.

WARTUNG

Waschen Sie die Säule häufig mit sauberem Wasser und trocknen Sie sie nach dem Waschen gründlich ab, um Kalkablagerungen zu vermeiden. Salzablagerungen, Kalkablagerungen, eventuelle Oxidflecken so schnell wie möglich entfernen; Zwischenräume, Kupplungen, sichtbare Schrauben usw. reinigen.

Nur Mikrofasertücher verwenden und bei gebürsteten Oberflächen die Richtung der Oberfläche beachten. Unbedingt zu vermeiden sind: scheuernde Tücher und Produkte (einschließlich pulverförmiger Reinigungsmittel), alle Reinigungsprodukte, die Bleichmittel/Salzsäure enthalten. Setzen Sie die Säule niemals den Dämpfen säurehaltiger Produkte aus, die zur Reinigung von Böden und Wänden verwendet werden, auch nicht im Freien, wenn sie in der Nähe unseres Produkts angewendet werden. In besonders aggressiven Umgebungen (Strände, Badeanstalten, im Allgemeinen Umgebungen mit hoher Salzkonzentration) empfiehlt es sich, nur Produkte mit MX Supermirror zu installieren und die Oberfläche regelmäßig zu pflegen. Bei längerer Nichtbenutzung empfiehlt es sich, das Produkt in umgekehrter Reihenfolge wie in den Installationshandbüchern beschrieben zu demontieren. Sollte dies nicht möglich sein, ist es ratsam, alle abnehmbaren Teile (Kartuschen, Schrauben, Duschköpfe, Perlatoren, Schläuche usw.) zu demontieren und die Wasserzufuhr zu unterbrechen.

HINWEIS: Damit die Garantie anerkannt werden kann, muss dem Produkt ein kontrollierbarer Filter vorgeschaltet werden.

AISI 316 L		CLEANING / NETTOYAGE / REINIGUNG / PULIZIA / REINIGING			
					Hydrochloric acid Muriatic Acid Hydrofluoric Acid Chlorine water Bleaching solution
WATER 	LIQUID SOAP 	MICROFIBER 	ROUGH SPONGE 	ACID/ABRASIVE DETERGENT 	



fontealta
in&out steel concept

Via Libeccio 13/15 | I-55049 Viareggio (Lu) | tel +39 0584 969041 | info@fontealta.it

